





⚠ WARNINGS

-  **Hot! Do not touch!** The glass and surfaces of this appliance will be hot during operation and will retain heat for a while after shutting off the appliance. Severe burn may result.
-  Carefully supervise children in the same room as appliance.
- If small children are present in the home, it is recommended that this appliance be used with a fire screen kit.

NATIONAL FIREPLACE INSTITUTE

CERTIFIED
www.nficertified.org

We suggest that our woodburning hearth products be installed and serviced by professionals who are certified in the U.S. by the National Fireplace Institute® (NFI) as NFI Woodburning Specialists or who are certified in Canada by Wood Energy Technical Training (WETT).

 **Wood Energy Technical Training**
www.wettinc.ca

Installation and Operating Instructions

This installation manual will help you obtain a safe, efficient, dependable installation for your fireplace and chimney system. Please read and understand these installation instructions before beginning the installation or operating the fireplace.

CAUTION: Do not attempt to modify or alter the construction of the fireplace or its components. Any modification or alteration of construction may void the warranty, listings and approvals of this system. In that case, Security Chimneys International Ltd will not be responsible for damages. Install the fireplace only as described in these instructions.

SAVE THESE INSTRUCTIONS FOR FUTURE REFERENCE

WARNING: This fireplace cannot be operated without doors. Consult your dealer to select the correct door model of your choice.

WARNING: This fireplace is designed for use as a supplemental heater. They are not intended for continuous use as a primary heat source.

 Listed to standards:
 ULC-S610, UL-127
 Report # 3047213

Intertek

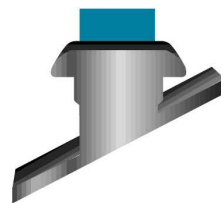

SECURITY CHIMNEYS INTERNATIONAL

2125 rue Monterey, Laval, Québec, Canada, H7L 3T6

TABLE OF CONTENTS

		Page
1.	SAFETY RULES	1
2.	CERTIFICATION LABEL	2
3.	THE FIREPLACE	3
	3.1 INTRODUCTION	3
	3.1.1 Parts Required	
	3.1.2 Additional Equipment (optional)	
	3.2 OPERATING THE BIS TRADITION™	4
	3.2.1 Fuel	
	3.2.2 First Fires	
	3.2.3 Heat Output	
	3.2.4 Primary air and air boost controls	
	3.2.5 Time delayed air boost system	
	3.2.6 Accelerated Combustion	
	3.2.7 Medium Combustion	
	3.2.8 Slow Combustion	
	3.2.9 Building a Fire	
	3.2.10 Refuelling For Best Performance	
	3.2.11 Smoking – Causes And Troubleshooting	
	3.3 MAINTAINING YOUR BIS TRADITION	9
	3.3.1 Creosote	
	3.3.2 Chimney Maintenance	
	3.3.3 Dealing With a Chimney Fire	
	3.3.4 Finish Door Casing Care	
	3.3.5 Ashes	
	3.3.6 Refractory Brick Replacement	
	3.3.7 Door Installation	
	3.3.8 Door Adjustment	
	3.3.9 Glass Care – Replacement	
	3.3.10 Glass Care – Cleaning	
	3.3.11 Gasket Replacement	
	3.4 FIREPLACE INSTALLATION	12
	3.4.1 Locating the BIS TRADITION	
	3.4.2 Hearth Extension Requirements	
	3.4.3 Framing, Facing And Mantel	
	3.4.4 Fireplace Blower	
	3.5 HOT AIR DUCTING INSTALLATION (Optional)	18
	3.5.1 Gravity Kit	
	3.5.2 Central Forced Air Kit	
	3.6 OUTSIDE AIR KIT	22
	3.6.1 Outside Air Kit Installation	
4.	THE CHIMNEY	23
	4.1 CHIMNEY INSTALLATION NOTES	23
	4.2 CHIMNEY INSTALLATION INSTRUCTIONS	24
	4.3 OFFSET CHIMNEY INSTALLATION	27
	4.4 ANGLED WALL RADIATION SHIELD	30
	4.5 CHIMNEY SUPPORTS INSTALLATION	31
	4.6 MULTIPLE TERMINATIONS	32
	4.7 INSTALLATION INSTRUCTIONS FOR MASONRY APPLICATION	33
5.	PARTS AND COMPONENTS LIST	34
6.	OPTIONS	35
7.	APPENDIX (Specifications, Clearances, Replacement Parts)	35

1. SAFETY RULES FOR OPERATING YOUR FIREPLACE MODEL BIS TRADITION™

Warning: The BIS Tradition **must be installed with an outside air kit inlet**, which is included with the fireplace.

Warning: The fireplace must be operated with the doors fully opened or fully closed. If the doors are left partly opened, smoke may be drawn into the room. If the unit is operated with the doors fully opened, the optional fire screen must be used.

Warning: For spectacular fire view and optimum efficiency of your fireplace, we recommend that the wood be placed as far back as possible in the hearth.

- Use only Security Fireplace glass doors specifically designed for the model BIS TRADITION fireplace.
- When cleaning the fireplace, the ashes should be placed in a metal container with a tight fitting lid. The closed container of ashes should be placed on a non-combustible floor or on the ground outside the house, pending final disposal. If the ashes are disposed of by burial in soil or otherwise locally dispersed, they should be retained in the closed container until all cinders have thoroughly cooled.

Caution: Do not block the hot air vents on the fireplace as this will cause the fireplace to overheat.

Caution: Never use gasoline, kerosene, charcoal lighter fluid or similar liquids to start or rekindle a fire in this fireplace. Keep all such liquids well away from the fireplace at all times. Do not burn coal. The sulphur in coal will corrode the chimney.

Caution: Keep combustible materials at least 48” (1.2 m) away from the front of the fireplace opening.



Caution: Never leave children unattended when there is a fire burning in the fireplace.

Caution: Use only untreated wood. Wood protectors, metallic paper, coal, plastic, waste, sulphur and/or oil will damage the fireplace.

Caution: Do not use the BIS Tradition as an incinerator to burn paper, cardboard or construction material such as pressed wood, plywood or lumber.

WARNING: THIS FIREPLACE HAS NOT BEEN TESTED WITH AN UNVENTED OR VENTED GAS LOG SET NOR A FIREPLACE INSERT. TO REDUCE RISK OF FIRE OR INJURY, DO NOT INSTALL AN UNVENTED GAS LOG SET NOR A FIREPLACE INSERT INTO THIS FIREPLACE.

2. CERTIFICATION LABEL

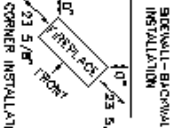
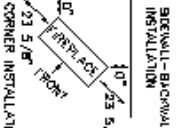
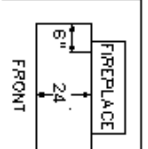
<p>Warnock Hersey</p>  <p>CH-US</p> <p>TESTED TO ULC S640 / UL 127 TESTÉ SELON (June / Juin 2004)</p> <p>CLEARANCES TO COMBUSTIBLES: SIDE WALL: 24" (610 mm) (FROM DOOR EDGE) MANTLE: 56" (1422 mm) (ABOVE BASE OF THE FIREPLACE) BACK WALL AND FIREPLACE SIDE: 0" (0 mm) (FROM SPACERS) CEILING HEIGHT: 6'8" (2032 mm) (ABOVE THE BASE OF FIREPLACE) CHIMNEY: 2" (51 mm)</p> <p>DEGAGEMENTS AUX COMBUSTIBLES: MUR LATÉRAL : 24 po. (610 mm) (DE L'OUVERTURE DE LA PORTE) LINTÉAU : 56 po. (1422 mm) (AU-DESSUS DE LA BASE DU FOYER) MUR ARRIÈRE ET CÔTÉ DU FOYER : 0 po. (0 mm) (DES ESPACEURS) HAUTEUR PLAFOND : 6'8" (2032mm) (AU-DESSUS DE LA BASE DU FOYER) CHEMINÉE : 2" (51 mm)</p> <p>LISTED FACTORY BUILT FIREPLACE FOYER PRÉ-FABRIQUÉ HOMOLOGUÉ MODEL / MODÈLE: BIS TRADITION</p> <p>TRAD-</p>	<ul style="list-style-type: none"> FUEL: WOOD ONLY NON COMBUSTIBLE HEARTH EXTENSION MUST BE INSTALLED AT FRONT OF UNIT EXTENDING 24in (610 mm) AT FRONT AND 6 in. (152 mm) TO SIDES OF DOOR OPENING. THIS FIREPLACE HAS NOT BEEN TESTED WITH UNVENTED GAS LOG SET. TO REDUCE RISK OF FIRE OR INJURY DO NOT INSTALL AN UNVENTED GAS LOG SET INTO THE FIREPLACE ELECTRICAL RATING: 115 V, 60 Hz CAN BE CONNECTED TO AMAS ONLY CHIMNEY AS DESCRIBED IN THE INSTALLATION INSTRUCTIONS. COMPONENTS USED WITH THE FIREPLACE MUST BE LISTED. SEE LIST IN THE INSTALLATION INSTRUCTIONS. REPLACE GLASS WITH CERAMIC GLASS 6 mm THICK. FOR SAFE OPERATION INSTALL IN ACCORDANCE WITH THE MANUFACTURER'S INSTRUCTIONS. CAUTION: COMBUSTION AIR OPENING MUST NOT BE OBSTRUCTED. DO NOT OVERFIRE THE FIREPLACE OPERATE THE FIREPLACE WITH DOORS FULLY OPEN OR FULLY CLOSED ONLY <p>CONTACT YOUR LOCAL BUILDING OR FIRE OFFICIALS ABOUT RESTRICTIONS AND INSTALLATION INSPECTIONS IN YOUR AREA</p>	<ul style="list-style-type: none"> COMBUSTIBLE: BOIS SEULEMENT UN TABLEAU NON COMBUSTIBLE DOIT ÊTRE INSTALLÉ À L'AVANT DU FOYER EXCÉDANT DE 24 po. (610 mm) À L'AVANT ET 6 po. (152 mm) DES CÔTÉS DE L'OUVERTURE DES PORTES. MAINTENIR LES MEUBLES ET AUTRES OBJETS À UNE DISTANCE SÉCURITAIRE DU FOYER. ALIMENTATION ÉLECTRIQUE : 115V, 60 Hz. UTILISER SEULEMENT AVEC UNE CHEMINÉE 7 po. (178 mm) DE DIAMÈTRE, MODÈLE S21004, HT80004, ACBI HOMOLOGUÉE PEUT ÊTRE RACCORDÉ À UNE CHEMINÉE DÉMONTÉE TEL QUE DÉCRIT DANS LE MANUEL D'INSTALLATION. LES COMPOSANTES UTILISÉES AVEC LE FOYER DOIVENT ÊTRE HOMOLOGUÉES. VOIR LA LISTE DANS LE MANUEL D'INSTALLATION. REPLACER LA VITRE AVEC UN VREBRE CERAMIQUE DE 6 mm D'ÉPAISSEUR. POUR UNE UTILISATION SÉCURITAIRE, INSTALLER CONFIRMÉMENT AUX DIRECTIVES DU FABRICANT. ATTENTION : NE PAS OBSTRUER LES ARRIVÉES D'AIR COMBURANT. NE PAS FAIRE SURCHAUFFER LE FOYER. LES PORTES DU FOYER DOIVENT ÊTRE TOTALEMENT OUVERTES OU TOTALEMENT FERMÉES LORSQUE LE FOYER FONCTIONNE.
<p>SECURITY CHIMNEYS INTERNATIONAL LTD</p>  <p>CHIMENÉES SÉCURITÉ INTERNATIONAL LTÉE</p> <p>LAVAL, QUÉBEC, CANADA.</p> <p>DATE OF MFG</p> <p>1 2 3 4 5 6 7 8 9 10 11 12</p> <p>YEAR</p> <p>2004 05 06 07 08 09 10 11 12</p>	<p>INSTALL WITH MINIMUM CLEARANCES TO WALLS SHOWN IN INCHES</p>  <p>FRONT 10"</p> <p>GENERAL-BLOCKING INSTALLATION</p>  <p>FRONT 10"</p> <p>CORNER INSTALLATION</p>  <p>FRONT 10"</p> <p>FRONT 23 5/8"</p>	<p>INSTALL AND USE ONLY IN ACCORDANCE WITH THE MANUFACTURER'S INSTRUCTIONS AND LOCAL BUILDING CODES.</p> <p>SPECIAL METHODS ARE REQUIRED WHEN PASSING THROUGH A WALL OR CEILING. SEE INSTRUCTIONS AND BUILDING CODES.</p> <p>PREVENT CREOSOTE FIRE: INSPECT CHIMNEY CONNECTOR AND CHIMNEY FLUE MONTHLY AND CLEAN IF NECESSARY. DO NOT OVERFIRE. IF HOME OR CHIMNEY CONNECTOR GLOOMS YOU ARE OVERFIRING.</p> <p>KEEP FURNISHINGS AND OTHER COMBUSTIBLE MATERIALS A CONSIDERABLE DISTANCE AWAY FROM APPLIANCE.</p> <p>HEARTH EXTENSION MATERIAL: - 1" THICKNESS NON-COMBUSTIBLE MATERIAL - OR EQUIVALENTS</p> <p>FLOOR PROTECTOR MINIMUM DISTANCE FROM OPENING IN INCHES</p>  <p>FRONT 6"</p> <p>FRONT 24"</p> <p>NPS81 Rev. 0</p>

3. THE FIREPLACE

3.1 INTRODUCTION

The BIS TRADITION™ fireplace is an energy efficient, heat circulating, close combustion fireplace. You will receive a lifetime of comfort and enjoyment from your fireplace provided it is installed, maintained and operated properly.

- Please read these instructions and retain this manual for future reference.
- Before beginning the fireplace installation, consult the local authorities to obtain your building permit and check your local building codes. Install the fireplace only as described in these instructions and using only Security Chimneys International components.
- The BIS TRADITION fireplace is not intended for use with a gas log. Failure to follow these instructions will void the certification and the warranty of the fireplace and may result in an unsafe installation.

3.1.1 Parts Required

- Fireplace model BIS TRADITION
- Door kit
- Front facade kit
- UZY5 blower (included in the fireplace)
- VRUW blower speed control (included)
- Outside air kit. (included with the fireplace)
- UZY5 fan (included in the fireplace).
- 7" diameter chimney model Secure Temp^{S-2100+}, Nova Temp^{HT6000+}, Secure Temp^{GX} (U.S. only) or ACBI manufactured by Security Chimneys International only, including:
 - Chimney lengths
 - Elbows (where necessary)
 - Associated components as per these installation instructions

3.1.2 Additional Equipment (optional)

- 5" flexible venting system (central forced air kit - not EPA approved) (see section 3.5.2)
- Gravity venting system (see section 3.5.1)
- TUBINOX chimney (or PROJET SS), 7" diameter with adaptor for installation in a masonry chimney.

3.2 OPERATING THE BIS TRADITION™

3.2.1 *Fuel*

The BIS TRADITION fireplace is designed to work best when fuelled with seasoned cordwood. Hardwoods are preferred to softwoods since the energy content of wood is relative to its density. Hardwoods will result in a longer burning fire and less frequent refuelling. A moisture content of 15% to 20% (seasoned) is recommended. Wood that has been cut and split and let to dry under a cover for a period of one year will usually meet that criteria. Excessively wet wood will be difficult to burn and will result in lower efficiency, increased creosoting and deposits on the glass and in the chimney. Excessively dry wood will burn well but will also have higher emissions and shorter burning time.

Do not burn scrap or garbage, treated wood or wood such as driftwood from the ocean which has been exposed to salt or other chemicals. Salt or chemicals can corrode the firebox and chimney. Do not burn large amounts of paper, cardboard, Christmas tree branches or building construction materials. Intense firing with these materials may overheat the fireplace, causing damage to the unit, a fire or even possibly igniting a chimney fire if the chimney is creosoted.

Processed firelogs can be used. Refer to warnings and cautions markings on the packaging prior to use.

3.2.2 *First Fires*

Before using the fireplace make sure to remove the plastic wrapping on the door. Remove all remaining glue with mild soap. Make sure the doors are properly adjusted, thus avoiding colour change to finish due to overheat.

The first 5 or 6 fires should be small fires of short duration (about 30 to 60 minutes). This will help cure the refractory bricks. The first fires may produce slight smoking due to drying of the paint and steel and any dust accumulated on the fireplace will burn off at this time. It may set off a smoke alarm located in the same room. For this reason the room should be well ventilated for the first few fires.

3.2.3 *Heat Output*

The BIS Tradition is the latest member of the BIS family of high efficiency fireplace. The heat generated from its fire is more efficiently captured and distributed. In spite of the large amount of heat that the BIS Tradition can deliver, it should not replace the main source of heat in your home. This fireplace will bring extra warmth and ambiance to your home by distributing its heat as describe further in the manual.

3.2.4 Primary Air and Air Boost Controls

There is no flue damper in the BIS TRADITION™. As is common with air tight appliance, the combustion air control sets the flow of air entering the firebox. This allows for a more precise control of the fire. The combustion air control is located below the door on the left side. The main source of air (primary air) entering the firebox can be diminished by moving the air combustion control from left to right. The primary air is fully opened when the air combustion control is completely moved to the left. This air combustion control should be in the closed position when the fireplace is not in operation. This will minimize air leakage up the chimney. **The combustion air control should be opened before opening the doors to minimize the possibility of back draft coming into the room (figure 1-A)** More details are available in section 3.2.10.

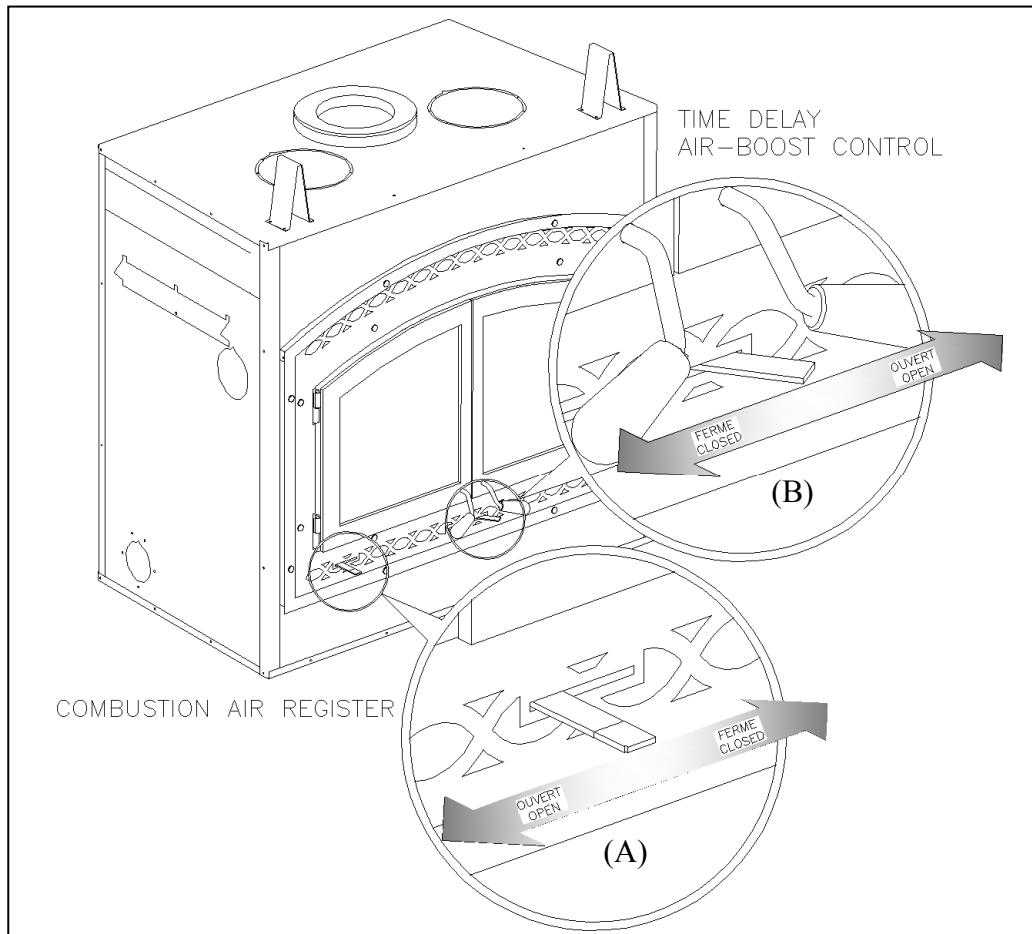

Figure 1

3.2.5 Time Delayed Air Boost System

The time delayed air-boost system register is located underneath the door handles. Placed in the fully opened position, a timer with a maximum duration of 2 hours is engaged. The register gradually reduces the amount of air injected, allowing for a better start of the fire, whatever the conditions. (See sections 3.2.9 and 3.2.10 for proper sequence of operation). This allows you to start the fire, set the primary air control to the desired burn level and the fireplace will automatically adjust itself to that level once the fire is fully established (figure 1-B).

3.2.6 Accelerated Combustion

The maximum heat output for the BIS TRADITION™ is achieved by burning with the door closed and the combustion air opened and pulled back. Through this method, the BIS TRADITION can produce up to 70 000 BTU of heat per hour.

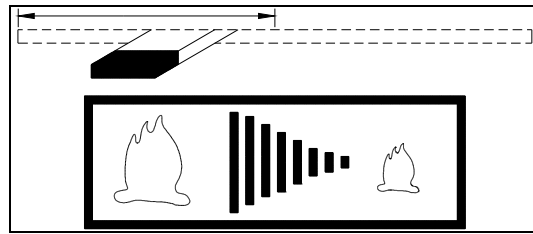

However, it will be necessary to reload with wood every one or two hours. This is the least efficient method of burning the BIS TRADITION.

Use caution when firing with the combustion air control wide open. Only burn cordwood in this manner. Small dry pieces of softwood and construction scraps will burn very intensely using this method and may damage the firebox.

3.2.7 Medium Combustion

This is the recommended mode of operating the BIS TRADITION and should be the one normally used since it will deposit the least amount of creosote on the glass and in the chimney. The combustion air control must be 3/4 closed. The precise setting will depend on many factors, including chimney length and the moisture content of the wood.

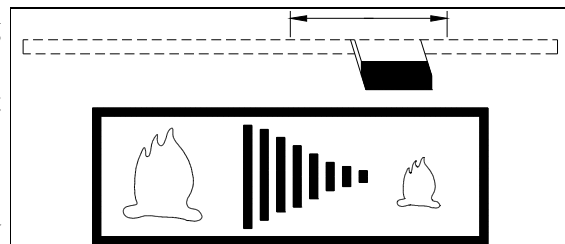

For instance, a long chimney will necessitate closing the damper more. To obtain the proper combustion, close the damper completely, then open it about 1/4" to 1/2". Three medium size pieces of cordwood burning on a bed of hot coals will generate an approximate heat output will of 35 000 BTU per hour and the loading time will be about every 3-4 hours. Softwoods may be burned using this method but the combustion time will be substantially reduced.

3.2.8 Slow Combustion

When the air combustion control is completely closed, the fireplace is in a slow combustion phase. If the hearth is hot enough, slow combustion will not stop the fire, but there will be a noticeable change in the flame pattern. The flames will be slow and may appear dirty if the wood is too wet (moisture content of 20% and more)

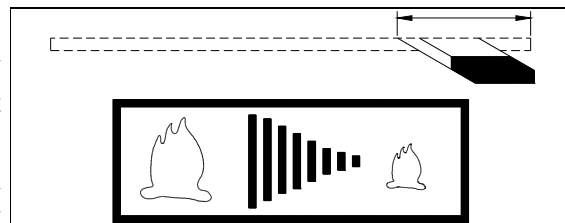

Do not allow the wood to burn without flame, since this will produce excessive creosote in the unit. Creosote may accumulate on the glass door. This method of burning should be used only after operating the BIS TRADITION with the air control opened to produce a hot fire for about an hour or at medium pace for at least 3 hours. Slow combustion can be used at night in order to reduce the heat output and to prolong the burn. The loading time will be between 6-8 hours. At this combustion rate, the level of BTUs is at its lowest.

3.2.9 Building a Fire

- A) To start a fire, place several crumpled up balls of newspaper in the firebox. Place small dry pieces of kindling on top of the paper, criss-crossing the kindling so that there are air spaces in between. The kindling should be placed at the center of the firebox so as to allow for sufficient air circulation.
- B) Adjust the primary air control and start the time delayed air-boost system by pushing the register towards the right. Light the newspaper. Leave the doors partially opened to facilitate the start-up.
- C) Once kindling fire is well established, cordwood can be added. You may set the primary air control to the desired level. (see Primary Air Combustion Control and air Boost Controls section for proper operation of the air controls).
- D) Set the primary control to the desired burn level. The fireplace will automatically go to that level after the fire is fully established and the air boost is closed.

The unit will burn best with 2-3 pieces of cordwood spaced 1 to 2 inches apart and allowing air to get under the fuel. Criss-crossing or arranging the fuel so that air can get underneath will help the fire to get started easily. The unit should be operated with the air control fully open long enough to get the cordwood well ignited.

3.2.10 Refuelling For Best Performance

To reload the BIS Tradition™ at the end of a combustion cycle, when no flame is visible and there are only ashes left:

- A) Completely open the air control level and the T.D.A.B. (Time Delay Air Boost) level (see figure 1).
- B) Open the doors about 1” and wait 5 seconds until the air flow has stabilized. Then open the doors completely, put the logs in and close the doors.
- C) Set the air control to the desired burn level. The T.D.A.B will close by itself progressively.

To reload the BIS Tradition when the fireplace is still hot with a few visible flames:

- A) Open the air control completely. The T.D.A.B can be set to a lower setting in order to facilitate lighting.
- B) Open the doors about 1” and wait 5 seconds until the air flow has stabilized. Then open the doors completely, put the logs in and close the doors.
- C) Set the air control to the desired burn level.

Note: For spectacular fire and optimisation of the fireplace efficiency, we recommend that the wood load be placed as far back as possible .

It may be necessary to close any fan(s) in operation during the refuelling process in order to minimise smoking in the room. It is recommended to wait 15 to 30 minutes before turning the fan(s) back on to ensure successful rekindling.

3.2.11 Smoking – Causes and Troubleshooting

To reduce the likelihood of smoke coming into the room when opening the door, set the combustion air controls to the left (“Accelerated Combustion”) before opening the door. Your fireplace has been designed and tested to provide smoke free operation. Occasionally, there may be a small amount of smoking upon lighting the fire, until the chimney heats up but this should not last. If the fireplace continues to smoke it is probably for one of the following reasons:

A. The doors are partially opened

When you open the doors, open them completely.

B. Negative pressure in the house

As the fire burns, air goes up the chimney. This air must be replaced through the outside air duct. When operating the BIS TRADITION™, open a nearby window temporarily to check if there is adequate air supply replacement.

C. Fans operating (e.g.: range hood)

These fans draw air out of the house and may actually cause a negative pressure in the house. Turn off all fans and open a nearby window to determine if this is the cause of the problem.

D. Wet wood

Wet or tarred wood will smoulder and smoke instead of burn properly.

E. Dirty or blocked chimney

Check to make sure the chimney is clear and clean.

F. Chimney not long enough

The minimum chimney height is 12 ft. not including the fireplace height. The chimney must extend at least 3 feet (915 mm) above its point of contact with the roof and at least 2 feet (610 mm) higher than any roof or wall within 10 feet (3 m) of it. When installed with offsets, the minimum chimney height is 15 ft. Additional height will increase draught and will decrease the tendency to smoke.

G. Poor chimney draft

With no fire, there should be sufficient draught to exhaust cigarette smoke introduced under the baffle. Chimneys installed against an outside wall without protection may generate back draught problems which will cause start-up problems. To prevent this, open a nearby window; roll up a piece of paper, light it and hold it in the upper part of the firebox to warm up the chimney. Wait until the draught is sufficient, then start the fire.

H. Blower for central forced air kit operating

Make sure that the blower is at the "off" position when you open the fireplace door for reloading.

3.3 MAINTAINING YOUR BIS TRADITION™

3.3.1 *Creosote*

When wood is burned slowly without a flame, it produces tar and other organic vapours which combine with expelled moisture to form a black deposit called creosote which accumulates on the flue lining. When ignited, this creosote makes an extremely hot fire. If the creosote accumulation is large, a creosote fire in the chimney can damage the chimney and overheat the surrounding wood framing. Creosote formation in a chimney can be minimized by making sure there is always visible flame burning, avoid smouldering fires and by proper refuelling techniques.

3.3.2 *Chimney Maintenance*

Regular chimney inspection and maintenance combined with proper operation will prevent chimney fires. Keep your chimney clean. Do not allow more than 1/16" creosote build up in your chimney. The amount of creosote will depend on variables such as frequency of use and type of fire. We recommend that you:

- A. Initially inspect the chimney system weekly. From this, you will learn how often it will be necessary to clean your chimney.
- B. Have your chimney cleaned by a qualified chimney sweep. If you wish to clean it yourself, we recommend using a stiff plastic or non-metallic brush. If a metal brush is used, its size should be slightly smaller than the flue to avoid damaging the chimney. Do not use a brush that will scratch the stainless steel interior of the chimney.
- C. Do not expect chemical cleaners to keep your chimney clean. The rain cap can be removed for inspection and/or cleaning of the chimney.

3.3.3 *Dealing With a Chimney Fire*

Regular chimney maintenance and inspection can prevent chimney fires. If you have a chimney fire, follow these steps:

1. **IMPORTANT:** Close the fireplace door and the combustion air controls; this will stifle the fire.
2. Alert your family of the possible danger.
3. If you require assistance, alert your fire department.
4. If possible, use a dry chemical fire extinguisher, baking soda or sand to control the fire. Do not use water as it may cause a dangerous steam explosion.
5. Ensure that sparks and hot embers coming out of the chimney are not igniting the roof.
6. Do not use the fireplace again until your chimney and fireplace have been inspected by a qualified chimney sweep or a fire department inspector.

3.3.4 DOOR FRAME FINISH CARE

Use a glass cleaner and a soft cloth to polish the casing. Do not use abrasives such as steel wool, steel pads or an abrasive polish for they may scratch the frame's finish.

3.3.5 Ashes

Remove ashes only when the fire is out and the ashes are cold (24 to 48 hours after the fire is out). Use a metallic container to dispose of the ashes.

3.3.6 Refractory Brick Replacement

The intense heat of the fire will normally cause hairline cracks in the refractory brick. These cracks can be minimized by proper curing as described in section 3.2.2. They will not normally diminish the effectiveness of the refractory brick. If large cracks develop, then the refractory should be replaced. To replace the refractory bricks, follow these steps:

1. Remove the side refractory brackets (6)
2. Remove the front refractory bricks (3)
3. Remove the bottom refractory brick (4)
4. Remove the left side refractory bricks (5)
5. Remove the right side refractory bricks (2)
6. Remove the back refractory brick (1)
7. Remove the deflectors (7) above the tubes
(Can be removed without removing other bricks for chimney cleaning)

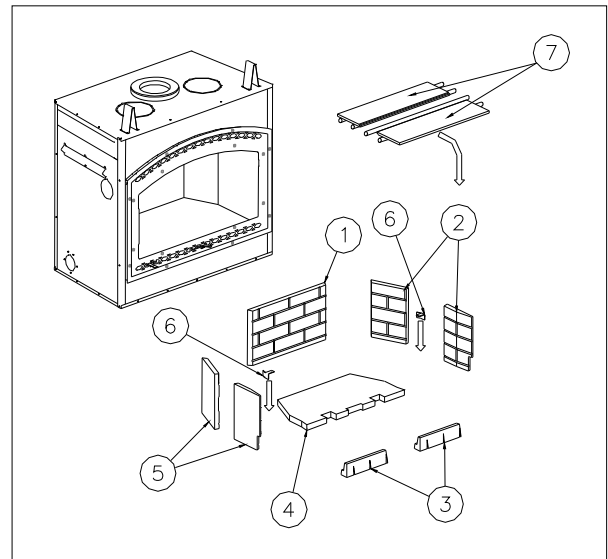

Figure 2

To install the new refractory bricks, follow the above steps in reverse.

3.3.7 Door Installation

The doors must be put in place only when the installation of the BIS TRADITION™ is completed. All you have to do is fit the male part of the hinge, already on the door, to the female part, which is on the fireplace. To remove the doors, simply pull them up from the hinges. The door adjustment has been set at the factory. If the fit is still not perfect, you can adjust the door using the hinge screws. (See figure 6-1)

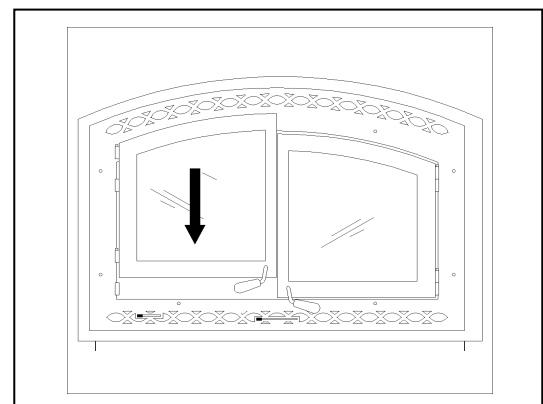

Figure 5

3.3.8 Door Adjustment

The doors may need to be adjusted to be completely airtight. The gaskets' airtightness can be adjusted using the adjustment screw located on the right side of the fireplace façade. (An Allen key #1/8 – not supplied - will be necessary for this adjustment) (see figure 6-2)

3.3.9 Glass Care - Replacement

The glass used for the BIS TRADITION™ is a high temperature ceramic glass (1400°F). If the glass breaks or cracks, it must be replaced with an identical ceramic glass. Tempered glass or ordinary glass will not withstand the high temperatures of the BIS TRADITION. Replacement glass should be purchased from a Security Chimneys International dealer (see “Replacement Parts”, Section 5).

Do not operate the unit with cracked or broken glass.

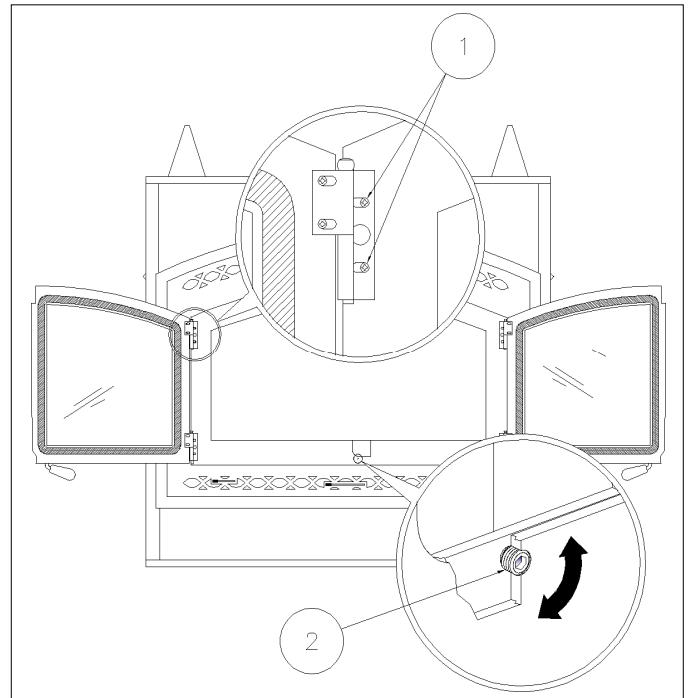

Figure 6

3.3.10 Glass Care - Cleaning

The BIS TRADITION is designed to keep the glass clean under normal operating conditions. If the BIS TRADITION is operated continuously with the combustion air controls closed, the glass will tend to get dirty unless the fuel, firebox and glass are maintained at hot temperatures (see section 3.2.10). To clean the glass, there are a number of specially designed cleaners to remove creosote. Your authorized Security dealer can recommend a suitable cleaner. Regular household glass cleaners will not clean creosote. Do not use abrasives such as steel pads, steel wool or oven cleaner as they will scratch the glass.

DO NOT USE CHEMICAL GLASS CLEANERS ON PAINTED SURFACES AS IT MAY CAUSE THE PAINT TO PEEL.

CAUTION : Do not allow window cleaner to get in contact with door gasket or paint on facade or door. Once closed, contact of glass cleaner with the fireplace façade can provoke paint peeling off.

3.3.11 Gasket Replacement

Remove the doors from the unit (see section 3.3.7) and lay them on a clean nonabrasive surface. To replace the gasket, first remove all of the old gasket and gasket cement. Make sure that the surface is totally clean before applying new cement (a high temperature silicone caulking rated at 500°F, 260°C, is suitable) or adhesion problems may result. Apply gasket cement to the gasket channel and install the new gasket. This replacement part is available from your Security dealer in the following dimensions:

<u>Gasket</u>	<u>Part #</u>	<u>Length</u>	<u>Quantity</u>	<u>Dimensions</u>
Around the glass	PR-SR-1685C	61 3/4"	2	1" width x 3/16" thick
On the door frame	PR-SR-1823I	48 3/8"	2	3/4" dia.
between the doors	PR-SR-1823J	17 5/8"	2	3/4" dia.

3.4 FIREPLACE INSTALLATION

3.4.1 *Locating The BIS TRADITION™*

The best location to install your fireplace is determined by considering the location of windows, doors, and the traffic flow in the room where the fireplace is located, allowing space in front of the unit for the hearth extension and the mantel, and taking into consideration the location of the hot air ducts (optional), outside air kit and chimney. If possible, you should choose a location where the chimney will pass through the house without cutting floor or roof joists (see fireplace dimensions on page 13).

Usually, no additional floor support is needed for the fireplace. The adequacy of the floor can be checked by first estimating the weight of the fireplace system. Weights are given in the appendix. Next, measure the area occupied by the fireplace. Note the floor construction and consult your local building code to determine if additional support is needed.

The BIS TRADITION fireplace may be installed directly on the floor or on a raised base and a minimum of 6'8" measured from the base of the appliance to the ceiling is required.

When selecting the location, the chimney outlet position and the direction of the wind are important factor affecting the chimney performance. To allow a maximum draft and to reduce wind turbulence, the chimney must:

- Penetrate the highest part of the roof.
- Be installed as far as possible of roof offsets, trees or any other obstructions that may cause wind turbulence and back drafts in the chimney.
- The least amount of offsets (elbows) possible.

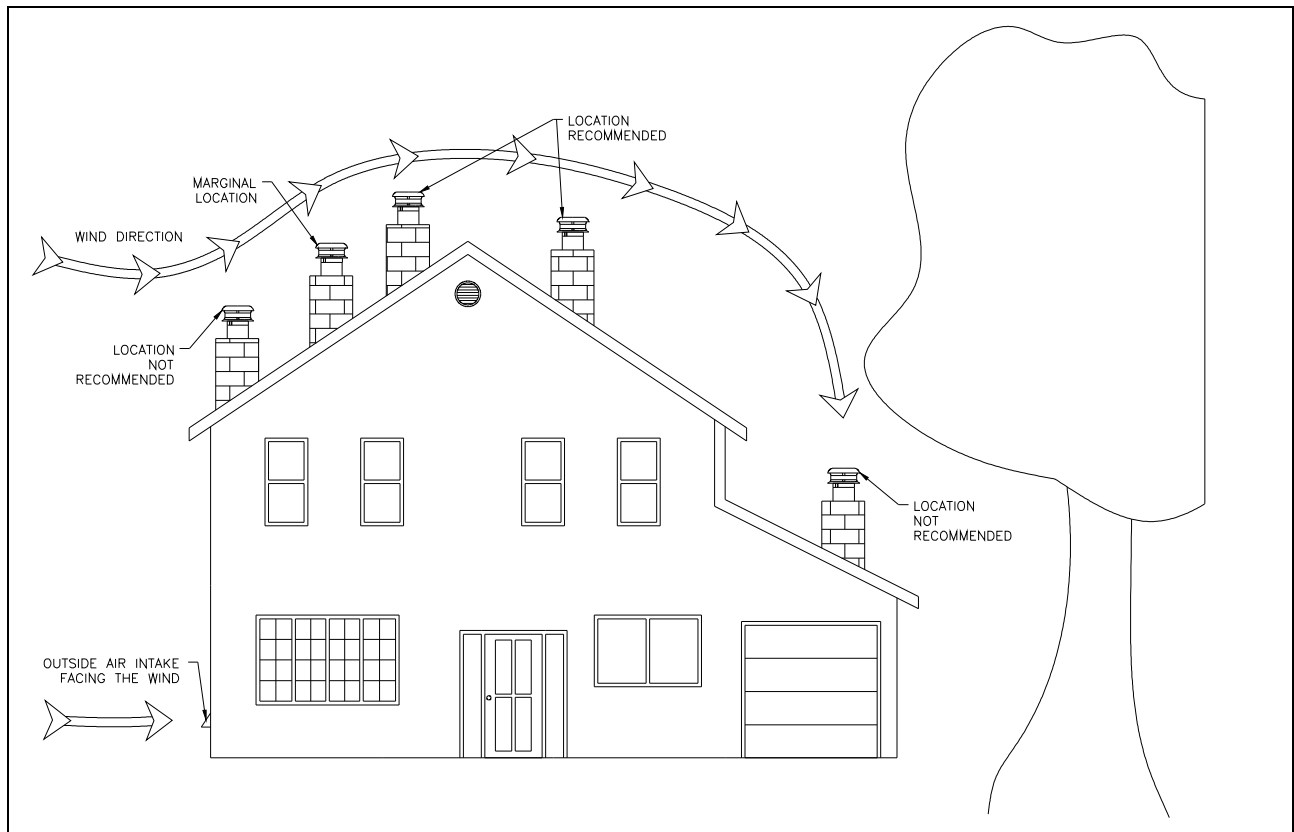

3.4.2 Hearth Extension Requirements

The BIS TRADITION™ fireplace may be installed directly on a combustible floor; however, the combustible floor in front of the fireplace must be covered with one inch (1 in.) of non-combustible support material (cement board, cement block or other) before applying the finish material (tile, marble, stone, etc.) (see figure 7). The supplied safety metal strip must be positioned as follows: One half under the front of the fireplace and the other half must extend on the floor over which the hearth extension will be built (figure 7.1).

*The safety metal strip must cover the entire width of the fireplace.

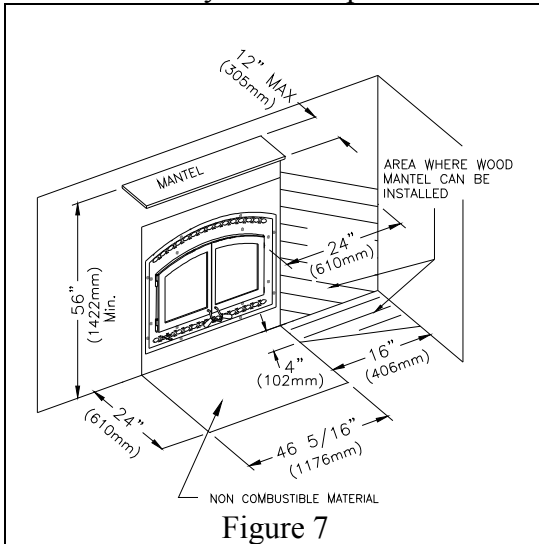

Figure 7

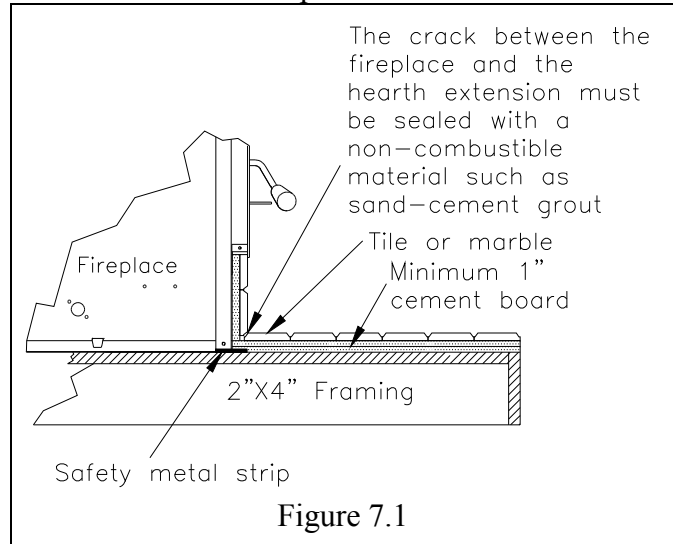
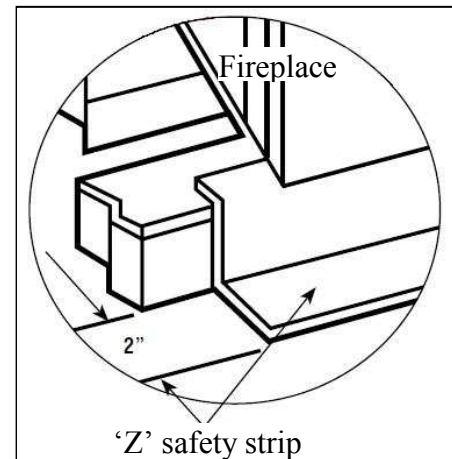

Figure 7.1

Elevated fireplace

Elevated fireplace installations require a special 'Z' metal safety strip (field provided), in place of the safety metal strip shown in figure 7.1. The safety strip should extend the full width of the fireplace. When more than one safety strip is used they must overlap by a minimum of 1".

Hearth extension of an elevated fireplace must respect the same minimal dimensions as a fireplace installed directly on the floor (figure 7).



'Z' safety strip

Figure 7.2

3.4.3 Framing, Facing And Mantel

The construction of the framing, facing, and mantel must be in accordance with the standards and the following illustrations (figures 8 to 12):

- A. Frame the fireplace using 2" x 3" or heavier lumber.
- B. **WARNING:** Combustible materials cannot be used in the space directly above the fireplace, except for the studs above the facade that support the facing and mantel. This area must remain empty for **a height of 6'8" (2032 mm)** measured from the base of the appliance.

C. Frame the fireplace with vertical studs at the sides of the fireplace running from floor to ceiling (see figure 10). If combustible facing is to be used, position the studs back, from the front edge of the fireplace the thickness of the facing material so that the facing can be installed flush with the fireplace facing. Frame headers between the vertical studs only as follows:

- Place 2" x 3" or 2" x 4" headers, only along the upper part of the front, side and back faces. Do not put wood or any combustible material within the area above the fireplace except on the front facing.
- Place headers only as required to support the facing and mantel.

D. **WARNING:** The fireplace must not be in contact with any insulation or loose filling material. Cover the insulation with gyproc panels or any other rigid material around the fireplace.

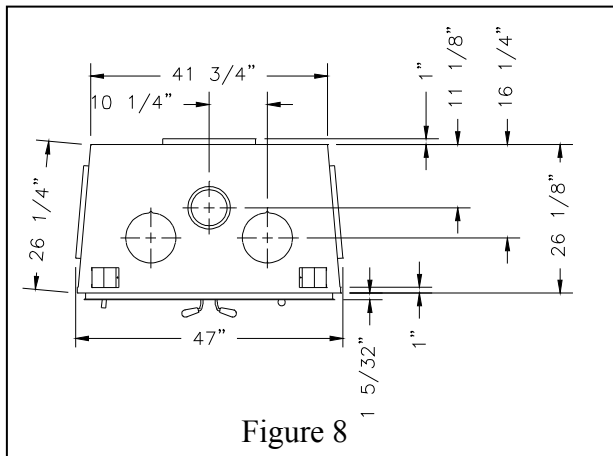

Figure 8

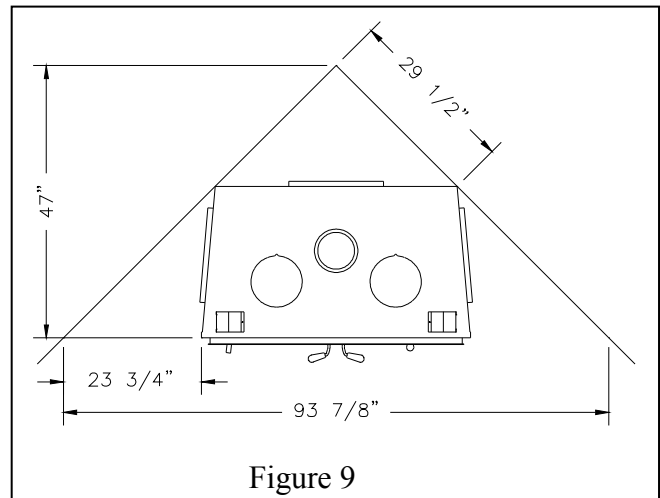

Figure 9

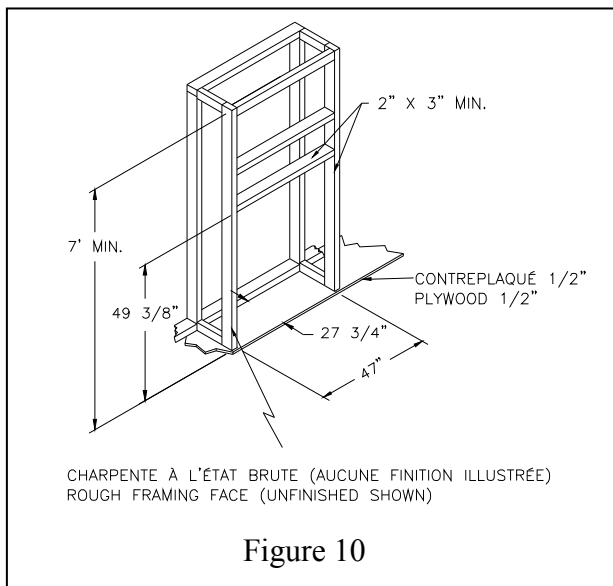

Figure 10

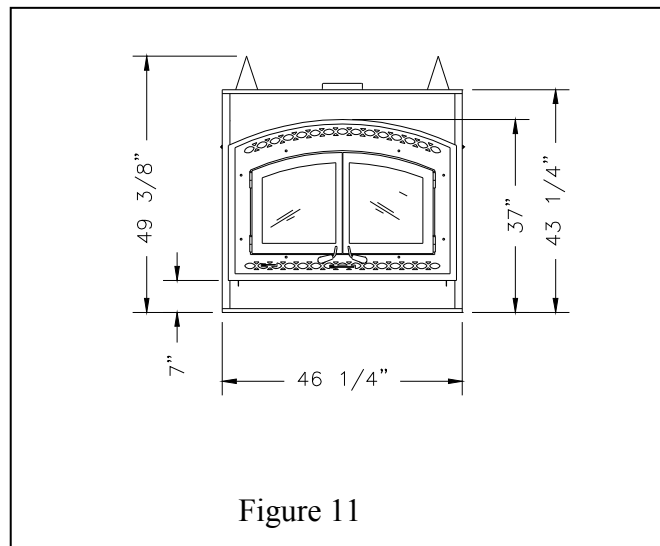

Figure 11

INSULATED CHASE CONSTRUCTION

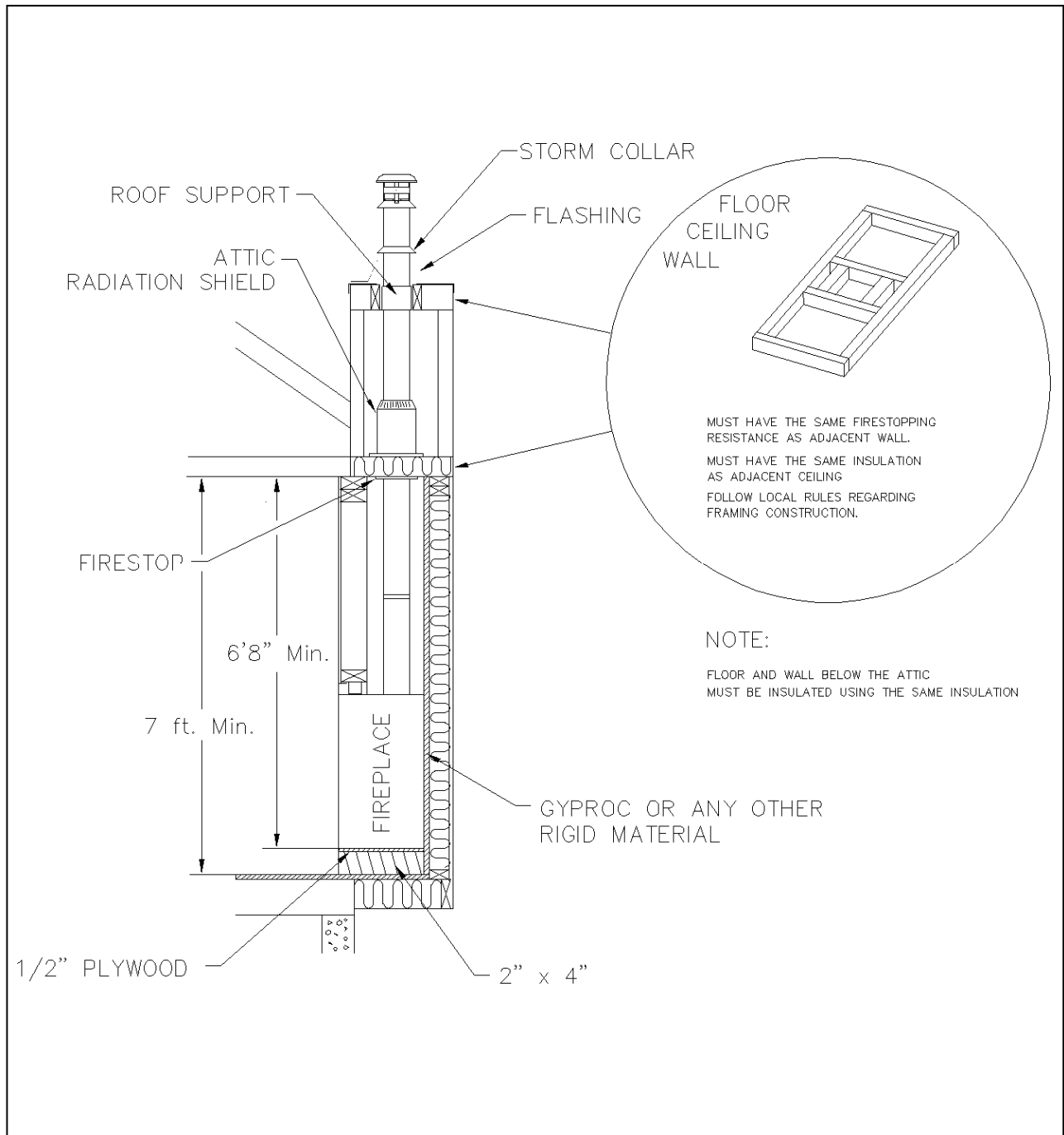

Figure 12

Facing

Note: The facade must be removable once installed. The facade is designed to overlap any facing material installed on the front of the fireplace. If thicker material is installed, use the facade as a template and make sure it can be easily removed for servicing.

1. Combustible material must be installed flush with the fireplace. It may not project in front of and on the fireplace (i.e. the steel facade of the fireplace) (figure 15).
2. Non-combustible materials such as brick, stone or ceramic tile may project in front of and onto the fireplace facing (figure 14).

1. Fireplace
2. Front of fireplace
3. Wood frame (2" x 3" min)
4. Drywall
5. Tiles
6. Rock board or other
7. Brick

FIREPLACE FRAME SECTION
(TOP VIEW)

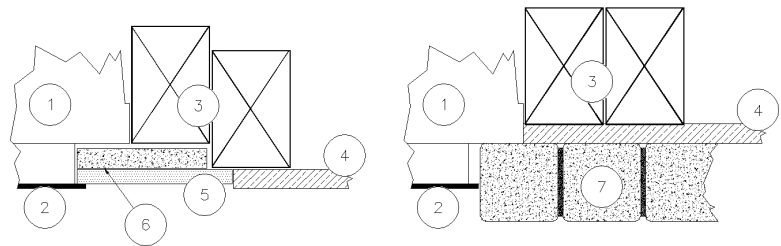

Mantel

The mantel must be installed at least 56" (1442 mm) above the base of the fireplace (figure 13).

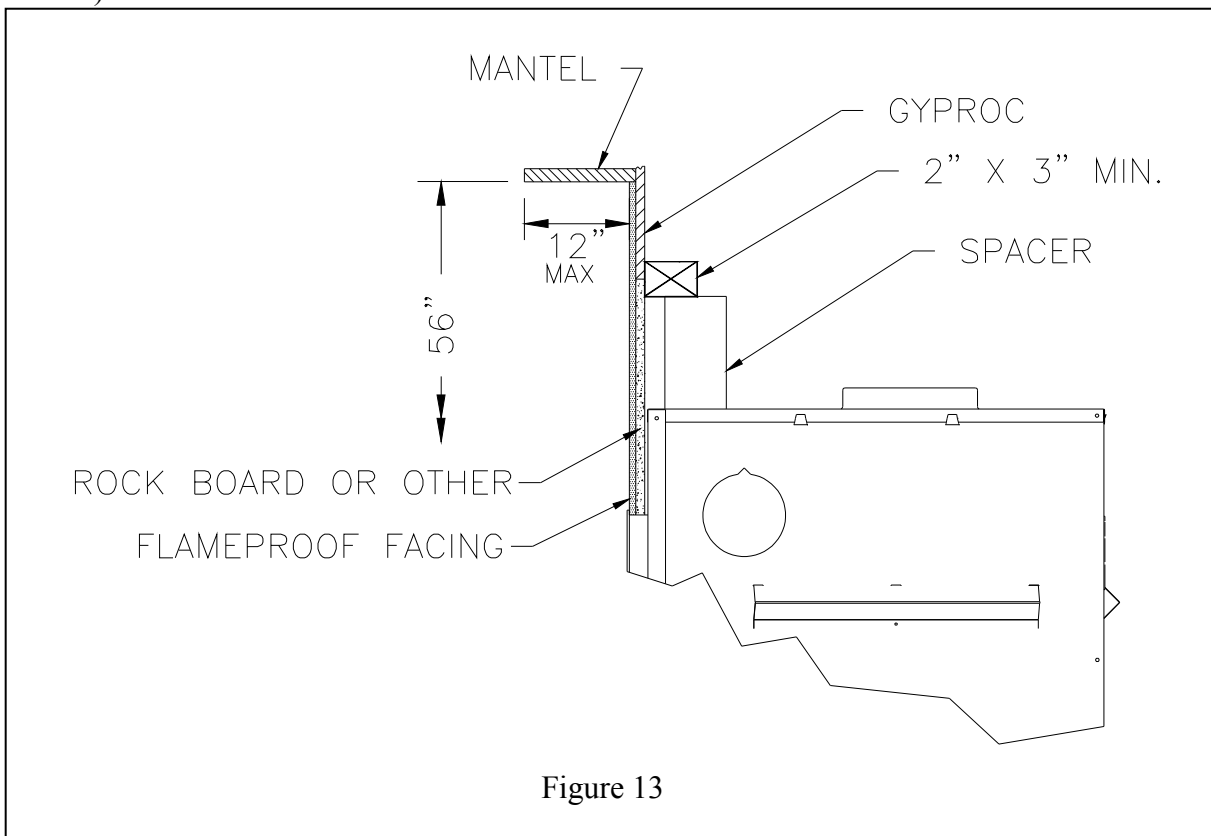
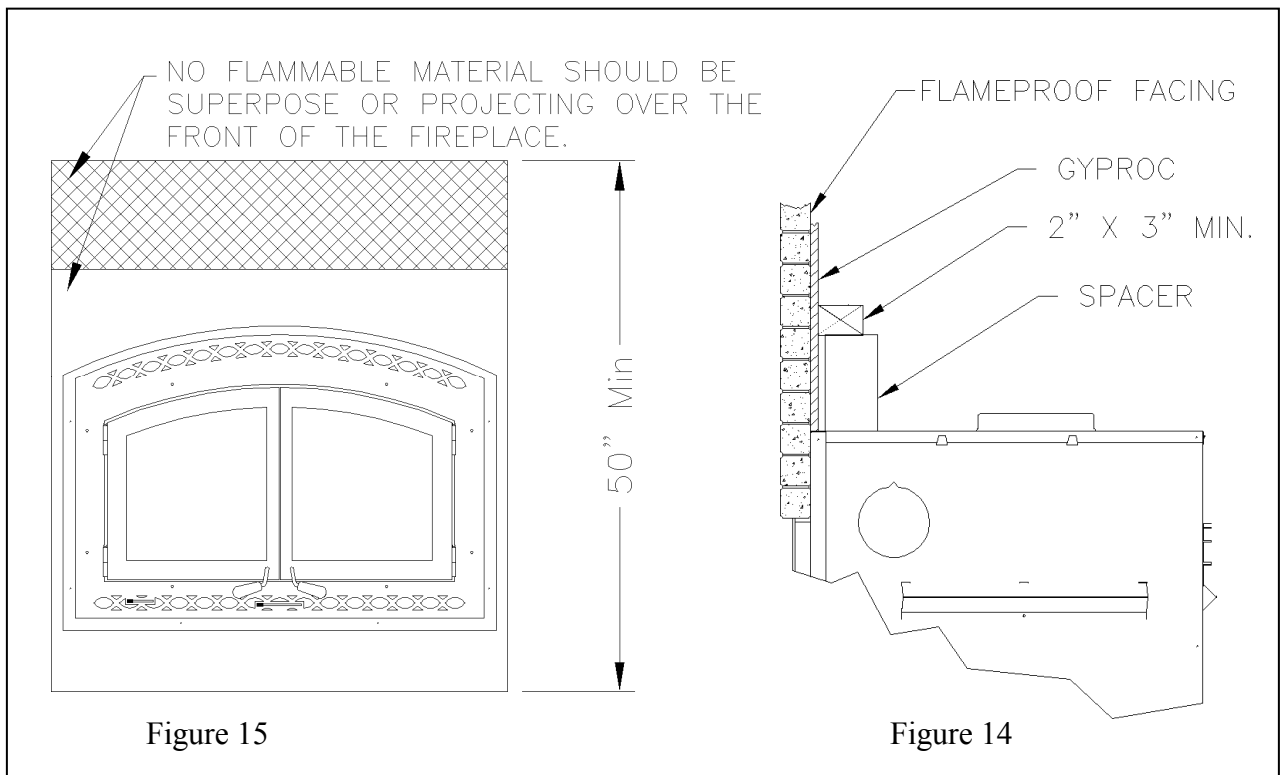

Figure 13



3.4.4 Fireplace Blower

The fireplace comes equipped with a heat activated blower. It is located in the bottom of the fireplace, towards the back. It uses regular 120V and must be connected to the main electrical circuit by a qualified electrician. For connection, use the electrical box supplied with the unit located on the bottom right corner of the fireplace.

If you wish to adjust the blower speed, an optional variable speed control (VRUW) can be installed in line with the wiring. Again, use a qualified electrician for installation.

If the blower requires servicing,

- 1- Remove the doors and the decorative facade
- 2- Remove the screw located below the blower motor that holds it to the back of the fireplace
- 3- Pull the blower out of the unit through the square hole located in the front bottom right corner.

3.5 HOT AIR DUCTING INSTALLATION (optional)

Different hot air ducting systems can be installed with the BIS TRADITION™:

- Gravity kit
- Forced air kit

The gravity kit is used when the rooms are on same level or floor as the fireplace or on an upper level or floor. If the heat to be distributed is on a lower level or floor or through the central heat duct of a furnace, then the forced air kit **MUST** be used.

3.5.1 *Gravity Kit*

Double hot air outlet including:

(See figure 16)

- 2 telescopic lengths 8" I.D.
- 2 90° elbows 8" I.D.
- 2 hot air outlet kits (grill and frames)
- 2 adaptors

See components list section 5.

Only the fan available with the fireplace can be used with the gravity kit .

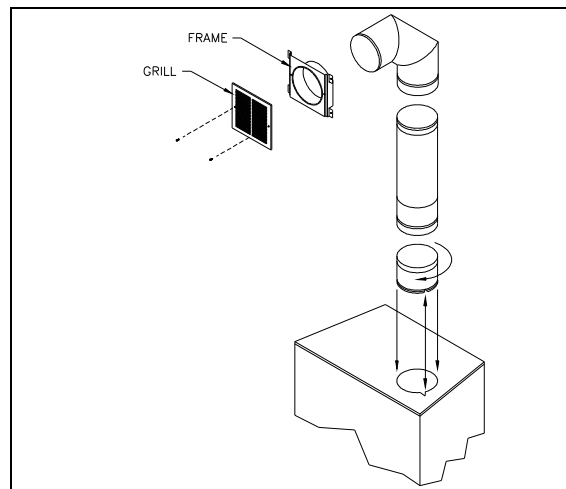

Figure 16

The safety rules for hot air ducting gravity kit installations are the following:

Minimum height*	68" (1727 mm)
Maximum length	See figure 18

* The height of the louver must be measured from the base of the BIS to the middle point of the louver.

WARNING: both pipes of the double hot air outlet must be installed. Any other installation may cause fire and void warranty.

When installing the double outlet system, the hot air outlets can be installed in the same room as the fireplace, or one or both of the outlets can be installed in adjacent or upper rooms. Installing the ducts at different elevations will tend to exhaust more heat out of the higher outlet (figure 18).

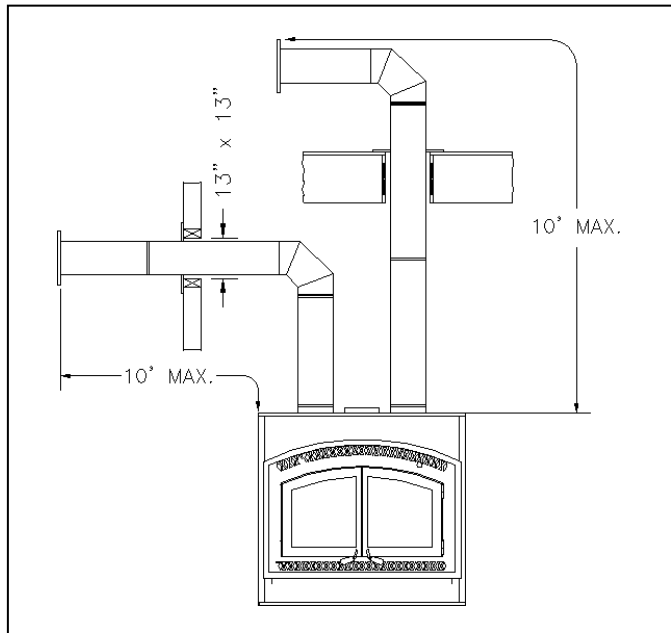

Figure 18

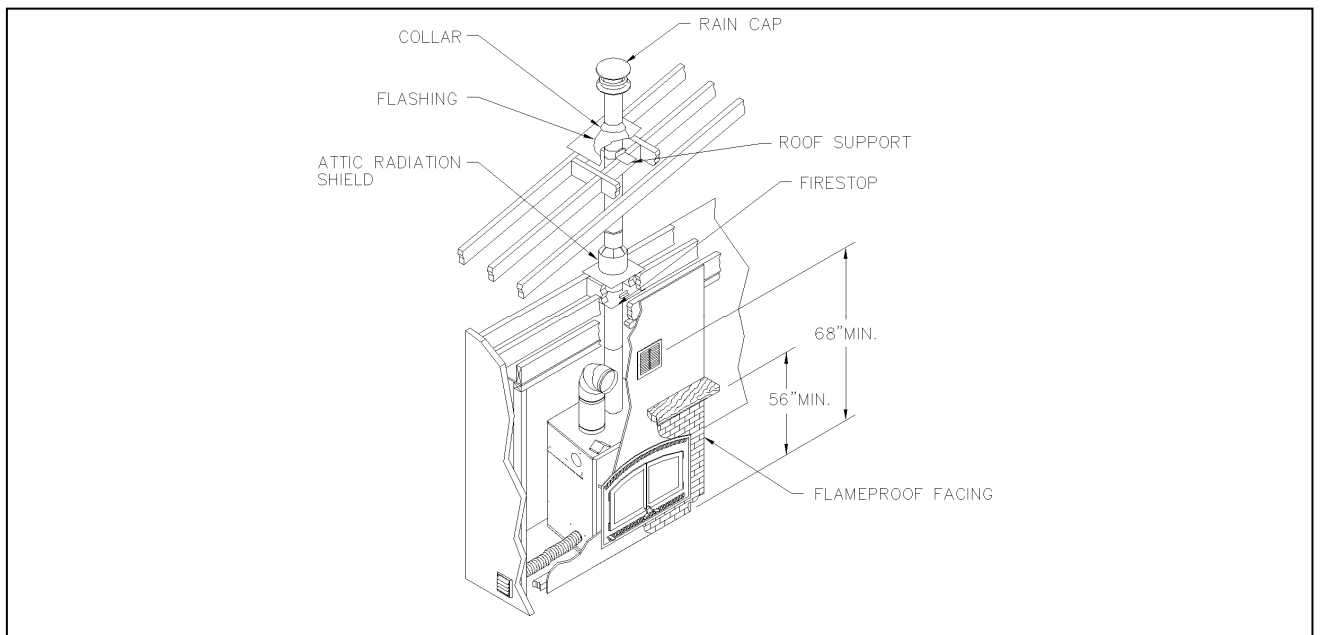

Figure 20

The duct system must be installed respecting the following:

1. Remove the plates closing up the 8" dia. holes on top of the fireplace. Then, cut the insulation in order to obtain two 8" dia. openings. Fix the adaptors on the fireplace openings by turning clockwise (figure 16).
2. Maintain at least a 2" (50 mm) clearance between the ducts and any combustible material; the required hole size is 13" x 13" (330 mm x 330 mm).

Exception: For the grills, the framing can be 10 ¾" x 10 ¾" (275 mm x 275 mm) to provide the clearance as required by the integral spacers on the double outlet duct system.

3. The maximum number of elbows in a run of duct is two.
4. Maintain at least 6 ½" (160 mm) clearance from the outlet grill framing to a combustible ceiling, side wall or mantel.
5. When traversing a combustible wall or floor, a firestop must be installed at the wall or floor penetration. The hole size must be 13" X 13". (330 mm x 330 mm)
6. Do not connect the hot air ducts to a central heating system. Malfunction of the heating system's fan will cause the fireplace to overheat. A furnace duct is only single wall and not double wall as is required for the BIS TRADITION™ hot air exhaust.
7. Use only Security Chimneys International grills and components as described in this manual. Other grills or registers may be too restrictive and may overheat the fireplace or ceiling.
8. Do not use insulated flexible ducts as they will overheat.
9. Do not use tees or any other components than the ones specifically listed here.
10. All ducts must extend upwards or horizontally. Never route the ducting downwards.
11. The hot air outlet grills must be installed with the louvers pointing downwards in order to prevent overheating adjacent ceilings.

3.5.2 *Central Forced Air Kit* (Not tested under EPA certification)

The knock-outs provided on the back and on the sides of the BIS TRADITION™ allow the connection of insulated flexible pipe which enables you to heat adjacent rooms up to 50 feet from the fireplace hot air outlet.

The ducting system must be installed as described below:

- A) Fix the adaptor at the back and/or the side of the fireplace by twist-locking the adaptor to the fireplace. You can use more than one outlet on the fireplace (figure 21).
- B) Attach the 5" flexible pipe, using the collars provided. **Important:** Make sure that the plastic wrapping around the flexible pipe will not be in contact with the fireplace.
- C) Route the flexible pipe to the chosen location. The ducting system can be installed either in an upper room or in a lower room.
- D) Attach the flexible pipe to the fan, using the collars (figure 22).
- E) Fix the back draft damper to the fan outlet.
- F) Attach a flexible pipe to the fan / flexible pipe adapter (square to round) and stretch it up to the location where the heat is required.
- G) At that point, the flexible pipe can be attached to any air distribution grill. It is possible to connect a flexible pipe to a central heating system. Make sure the pipe will be connected to the warm air supply duct, not to the return air duct (figure 22).
- H) Install the *blower heating and cooling thermostat* (HCTW) in that part of the house to be heated by the hot air duct. The thermostat can be switched to a cooling thermostat and installed in the same room as the unit. This thermostat will turn on the blower when the room where the fireplace is located becomes too hot.

This option requires electricity. Make sure that the connections to the fan have been made according to the local codes and comply with their requirements (see instruction provided with the thermostat). For more information regarding central forced are ducting, consult the BISFWK-1 installation sheet provided with the kit.

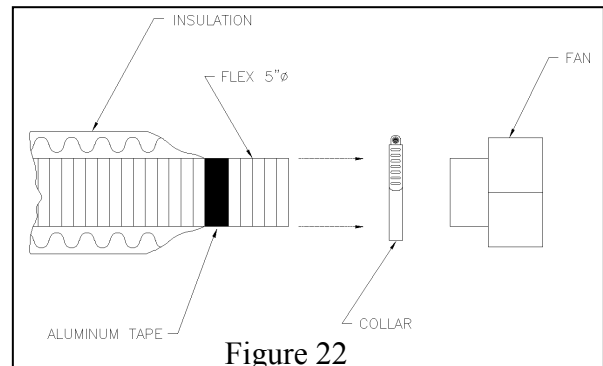
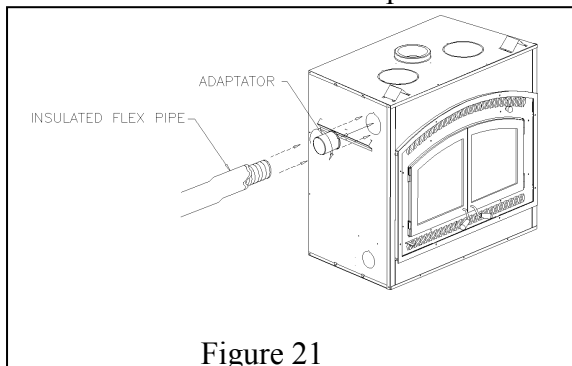

3.6 OUTSIDE AIR KIT

It is mandatory to install an outside air connection to the BIS Tradition™. The following components are required and are included with the fireplace:

- Outside air kit
- 4" adapter for fireplace connection

The outside air assembly must be installed according to the following requirements :

- A) Duct length should be kept to a minimum. The maximum length of a 4" interior diameter (100 mm) insulated flexible duct is 20 ft. (6.1 m). The duct can be extended to a maximum of 40 ft. (12 m) using a 6" interior diameter (150 mm) insulated flexible duct (See note below).
- B) The air intake register must not be installed more than 10 ft. (3050 mm) above the base of the fireplace.
- C) The fresh air must come from outside the house. The air intake must not draw air from the attic, basement or garage.
- D) The air intake should be installed where it is not likely to be blocked by snow or exposed to extreme wind and away from automobile exhaust fumes, gas meters and other vents.
- E) The duct and register may be installed above or below floor level.

Make a 4 ¼" (110 mm) hole in the outside wall of the house at the chosen location. From outside, place the outside air register in the hole (open side down) and fasten the register to the wall with screws as shown (see figure 24). Slip the pipe into the insulated sleeve. Place the insulated pipe over the register tube and over the fireplace's outside air connector (see figure 25). At each end, carefully pull back the insulation and plastic cover exposing the flexible pipe. Using the aluminium tape provided, wrap the tape around the joint between the flexible pipe and the air inlets. Carefully push the insulation and plastic cover back over the pipe. Using aluminium tape, fasten the plastic cover in place.

NOTE: We recommend not to exceed 20 feet of 4" flexible pipe. If you require a longer length we recommend that you use a 5" diameter flexible pipe for the complete run up to 30 feet and a 6" diameter pipe for a run of up to 40 feet.

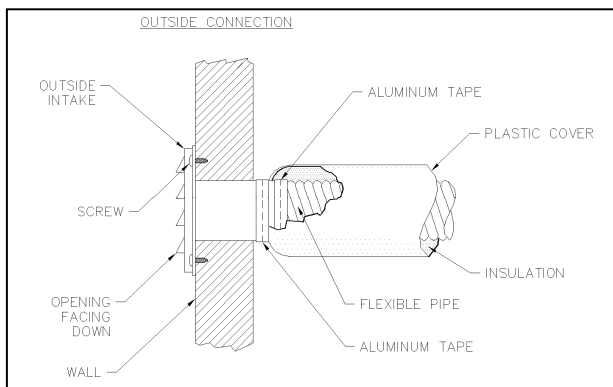

Figure 24

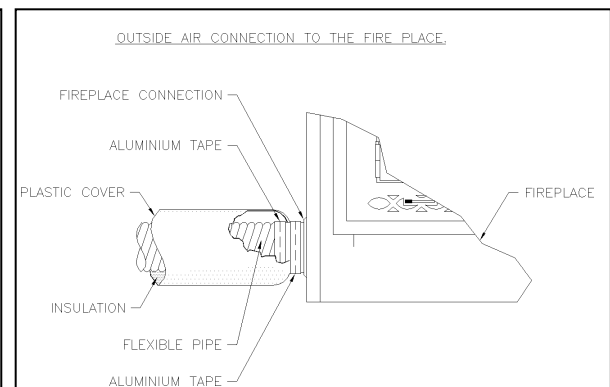

Figure 25

4. THE CHIMNEY

4.1 CHIMNEY INSTALLATION NOTES

1. If possible, install an interior chimney as it will provide better performance. In areas with continuous temperatures below 18°C (0°F), the use of an exterior chimney increases the likelihood of operating problems such as low draft, high rate of creosoting, and poor start-up characteristics. Exterior chimneys are also prone to down-drafting and flow reversal. Installations which are located on lower floors in the house, such as in a basement, in combination with an outside chimney, are especially prone to flow reversal.
2. The Security fireplace model BIS TRADITION™ is listed only with Security Chimneys International Ltd 7" dia. chimney systems model Secure Temp^{S2100+} / Nova Temp^{HT6000} / Secure Temp^{GX} (U.S only) or ACBI.
3. A chimney venting a fireplace shall not vent any other appliance.
4. The minimum chimney height is 12 ft. (3.7 m) excluding the fireplace.

NOTE : In areas where winter temperatures are normally below freezing, the air cooled chimney may produce condensation. This condensation may corrode the top of the fireplace and is not covered under warranty. For optimum performance of your fireplace, Security Chimneys International recommends the use of an Secure Temp^{S2100+} / Nova Temp^{HT6000+} or Secure Temp^{GX} chimneys.

5. All chimney installations must include at least one support in order to be able to take any lateral load. The maximum chimney length that can be supported by the fireplace is 9 ft. (2.75 m) for Secure Temp^{S2100+} / Nova Temp^{HT6000+} / Secure Temp^{GX} and 26 ft. (8m) for ACBI chimney. In altitude, add 18" (450 mm) to the chimney for every 2000 feet (600 m) above sea level.
6. The chimney must extend at least 3 ft. (915 mm) above its point of contact with the roof and at least 2 ft. (610 mm) higher than any wall, roof or building within 10 ft. (3m) of it (Figure 26).
7. If the chimney extends higher than 5 ft. (1500 mm) above its point of contact with the roof, it must be secured using a roof brace.
8. A rain cap must be installed on top of the chimney. Failure to install a rain cap may cause corrosion problems.
9. Cut and frame square holes in all floors, ceilings, and roof that the chimney will go through to provide a 2" (50 mm) clearance between the chimney and any combustible materials. Do not fill this 2" space with insulation or any other combustible material.
10. Portions of the chimney which may extend through accessible spaces must be enclosed to avoid contact with combustible materials or damage the chimney.

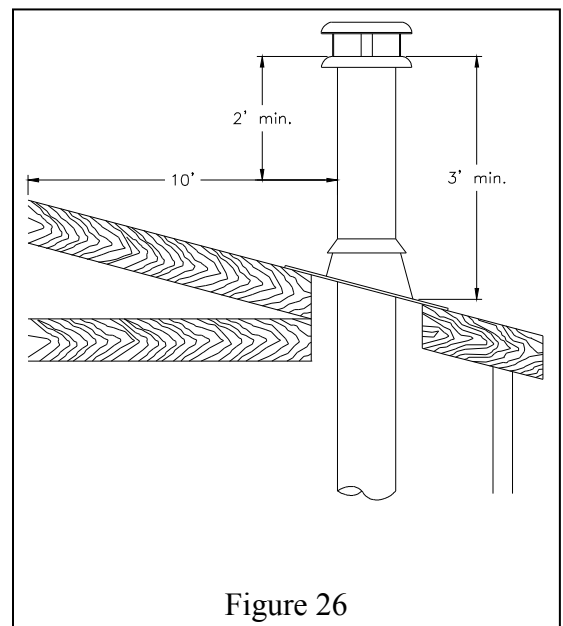

4.2 CHIMNEY INSTALLATION INSTRUCTIONS

1. Cut and frame the holes in the ceiling, floor and roof where the chimney will pass (see figure 27). Use a plumb bob to line up the centre of the holes. The sizes are indicated in table 1 for the floor and ceiling holes and table 2 (page 28) for the roof holes.

CHIMNEY MODEL	HOLE SIZE
Secure Temp ^{S2100+} Nova Temp ^{HT6000+} Secure Temp ^{GX}	15 in. (380 mm)
ACBI : Ceiling, floor and roof (1" clearance *)	15 in. (380 mm)
Wall	17 in. (432 mm)

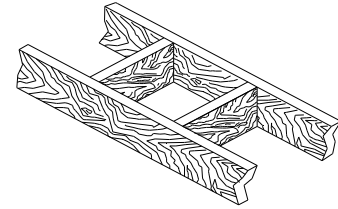

Figure 27

Table 1

* The following exception has been approved for this appliance; The required 2" pipe clearance may be reduced to a 1" clearance at the ceiling, floor and roof penetration points for AC chimney only. All other locations require 2" clearance.

- From below, install a firestop in each ceiling/floor separation through which the chimney will pass. At the attic level, install an attic radiation shield from above. (figures 28 & 29).
2. For Secure Temp^{S2100+} / Nova Temp^{HT6000+} / Secure Temp^{GX} chimneys, place the first chimney length on the fireplace. To lock it in place, turn ¼ of a turn clockwise. With the ACBI chimney, you must use a starter section before installing the first chimney length (figure 30). Continue installing chimney lengths making sure to lock each length in place.
 3. Every time the chimney passes through a ceiling or a wall, install the appropriate firestop. When you reach the desired height, install the roof support. (Refer to instructions included with the support). For an ACBI chimney use an universal support AC10SU.
 4. Put the roof flashing in place and seal the joint between the roof and the flashing with roofing pitch. (see figures 31 & 32). For sloping roofs, place the flashing under the upper shingles and on top of the lower shingles. Nail the flashing to the roof, using roofing nails.
 5. Place the storm collar over the flashing, and tighten it with the bolt supplied. Finally, seal the joint between the storm collar and the chimney, using silicone caulking.
 6. Install the chimney cap.

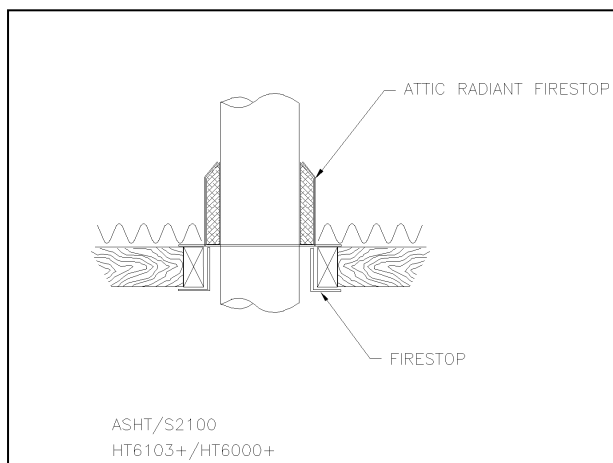

Figure 28

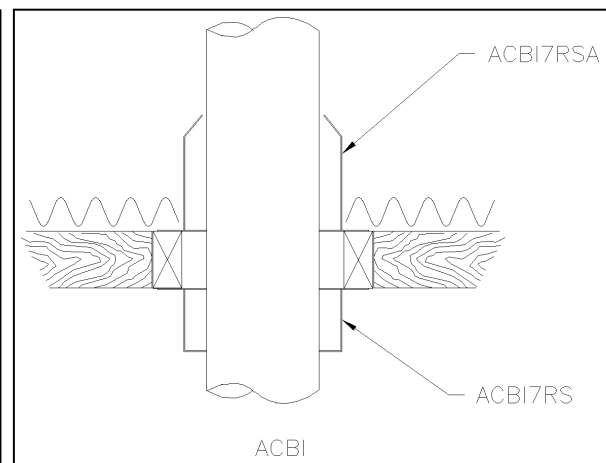

Figure 29

CHIMNEY INSTALLATION MODEL ACBI

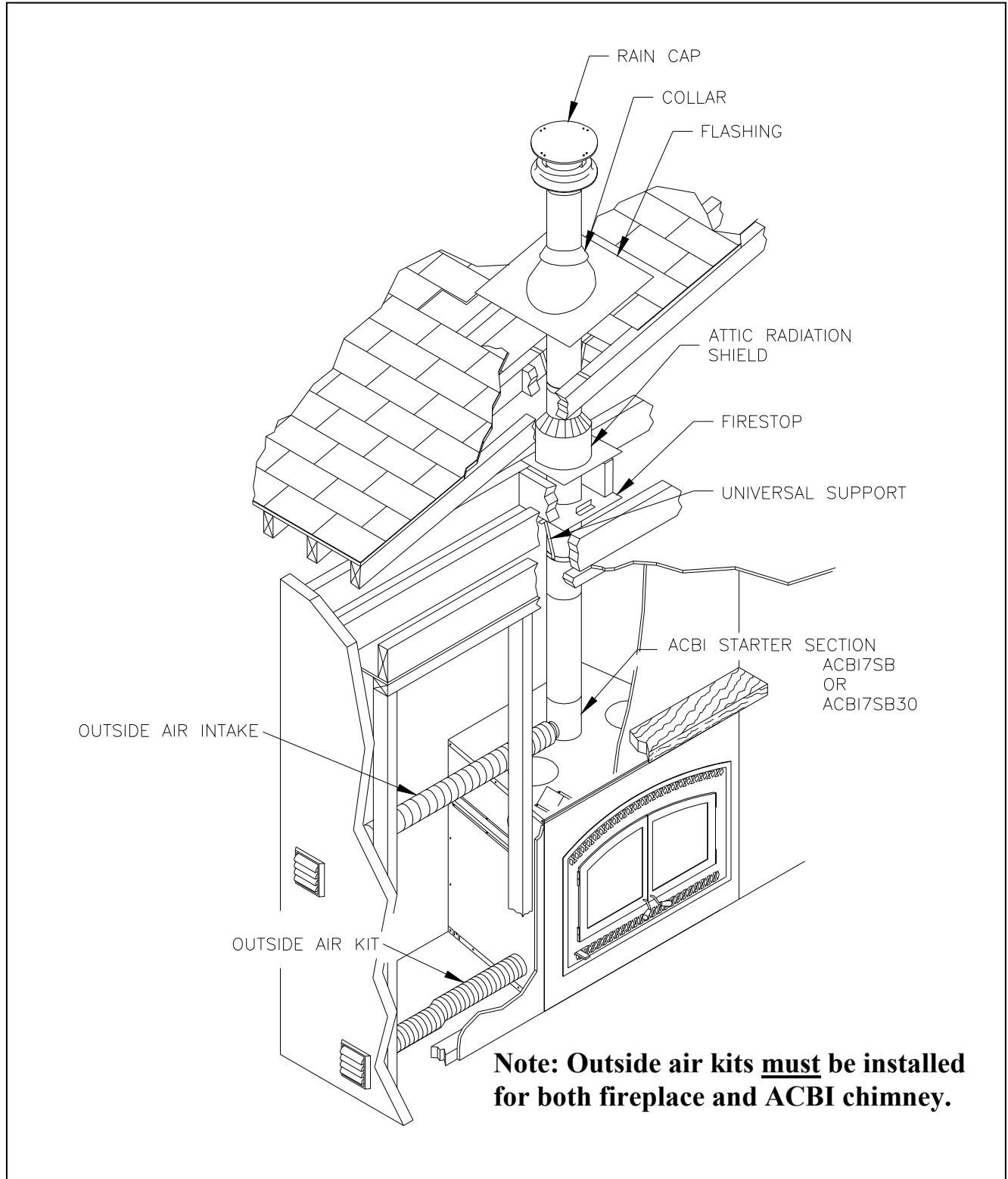

Figure 30

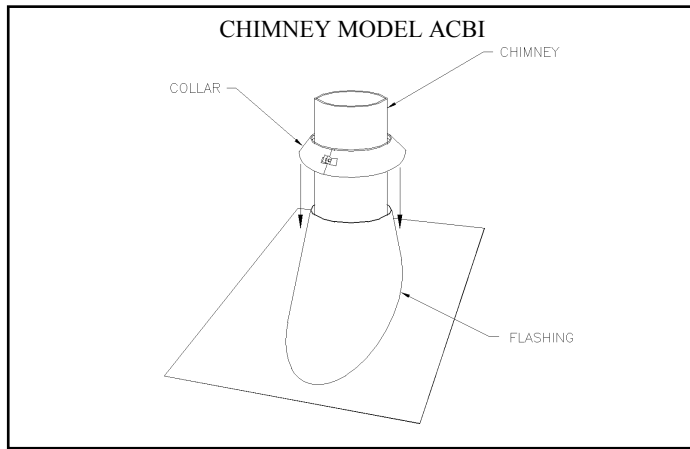

Figure 31

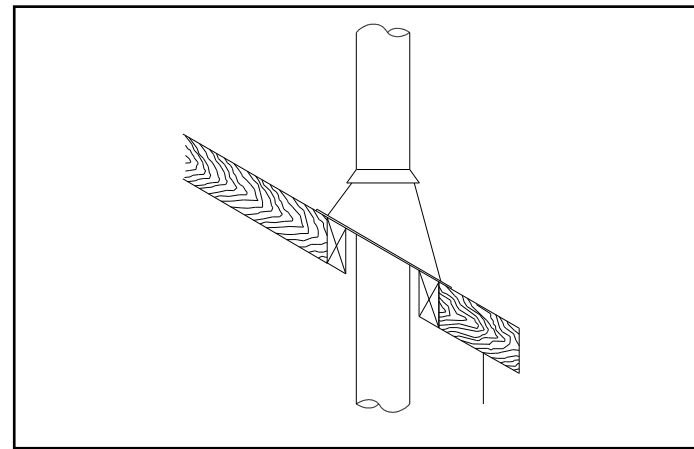

Figure 32

Table 2

ROOF DOWN SLOPE HOLE SIZE		
DEGREE OF SLOPE	Secure Temp ^{S2100+} Nova Temp ^{HT6000+} Secure Temp ^{GX}	ACBI
	7"	7"
0 *	15" (380 mm)	15" (380 mm)
2/12	15 3/8" (390 mm)	15 3/8" (390 mm)
4/12	16 1/8" (410 mm)	16 1/8" (410 mm)
6/12	16 7/8" (430 mm)	16 7/8" (430 mm)
8/12	18 1/4" (465 mm)	18 1/4" (465 mm)
10/12	19 5/8" (500 mm)	19 5/8" (500 mm)
12/12	21 3/8" (545 mm)	21 3/8" (545 mm)
* CROSS SLOPE HOLE SIZE		

4.3 OFFSET CHIMNEY INSTALLATION

The minimum chimney height when using elbows is:

Fireplace Model	BIS TRADITION™
Chimney Model	Secure Temp ^{S-2100+} / Nova Temp ^{HT6000+} / Secure Temp ^{GX} / ACBI
Vertical Installation	3.66 m (12')
Two (2) Elbows	4.57 m (15')
Four (4) Elbows	5.18 m (17')

Table 3

After reaching the location requiring the elbow, proceed as follows:

Secure Temp^{S2100+} / Nova Temp^{HT6000+} / Secure Temp^{GX} Chimneys

1. Install the first elbow; turn it in the required direction. Fasten it to the chimney with the three (3) ½" (12 mm) metal screws provided with the elbow.
2. Install the necessary chimney lengths to achieve the required offset. Lock the chimney lengths together: it is recommended to use three (3) ½" (12 mm) screws. If the offset length is made of two (2) chimney lengths or more, use an offset support halfway up the offset. If penetrating a wall, install a wall radiation shield (see figures 34 & 35).
3. Use another elbow to turn the chimney vertically. Secure the elbow, using three (3) ½" (12 mm) screws (provided with the elbow).
4. Use a plumb bob to line up the centre of the hole. Cut a hole for the chimney in the ceiling/floor. Frame this hole as described previously (refer to section 4.2).
5. From below, install a firestop (See figure 28).
6. A support (XST+ or XSO+) must be used on the first 15' section (5 m.).
7. Continue with the regular installation.

ACBI Chimney

1. Install the first elbow. Turn it in the required direction. To lock it in place, turn 1/8 of a turn. Fasten the straps attached to the elbow to the surrounding frame, using nails or drywall screws (figure 33).
2. Install the necessary chimney lengths to achieve the required offset. Lock the chimney lengths together. If penetrating a wall, use a wall radiation shield.
3. Use another elbow to turn the chimney vertically. Lock it to the chimney. Fasten the straps attached to the elbow to the surrounding framing using nails or drywall screws.
4. Use a plumb bob to line up the centre of the hole. Cut a hole for the chimney in the ceiling. Frame this hole as described previously.
5. From below, install a firestop. (see figure 29).
6. Continue with the regular installation.

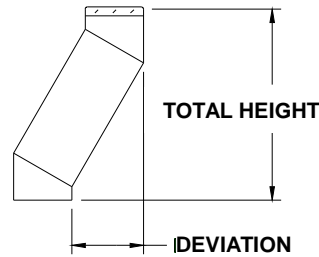

CHIMNEY 7"	ELBOW	DEVIATION & HEIGHT	ONE LENGTH BETWEEN ELBOWS					TWO LENGTHS BETWEEN ELBOWS						
			8"	12"	18"	24"	36"	48"	8" & 48"	12 & 48"	18 & 48"	24" & 48"	36" & 48"	48" & 48"
GX Secure Temp ^{S2100+} Nova Temp ^{HT6000+}	15°	DEVIATION	3 5/16" (84mm)	4 5/16" (110mm)	5 7/8" (149mm)	7 7/16" (189mm)	10 1/2" (267mm)	13 5/8" (346mm)	15 1/2" (394mm)	16 1/2" (419mm)	18 1/16" (459mm)	19 5/8" (498mm)	22 3/4" (578mm)	25 13/16" (656mm)
		HEIGHT	16" (406mm)	19 7/8" (505mm)	25 11/16" (652mm)	31 1/2" (800mm)	43 1/16" (1094mm)	54 5/8" (1387mm)	61 7/16" (1561mm)	65 1/4" (1657mm)	71 1/16" (1805mm)	76 7/8" (1953mm)	88 1/2" (2248mm)	100 1/16" (2542mm)
	30°	DEVIATION	7 3/8" (187mm)	9 3/8" (238mm)	12 3/8" (314mm)	15 3/8" (391mm)	21 3/8" (543mm)	27 3/8" (695mm)	30 7/8" (784mm)	32 7/8" (835mm)	35 7/8" (911mm)	38 7/8" (987mm)	44 7/8" (1140mm)	50 7/8" (1292mm)
		HEIGHT	20 11/16" (525mm)	24 3/16" (614mm)	29 3/8" (746mm)	34 9/16" (878mm)	44 15/16" (1141mm)	55 5/16" (1405mm)	61 3/8" (1559mm)	64 7/8" (1648mm)	70 1/16" (1780mm)	75 1/4" (1911mm)	85 5/8" (2175mm)	96" (2438mm)
CHIMNEY 7"	ELBOW	DEVIATION & HEIGHT	ONE LENGTH BETWEEN ELBOWS					TWO LENGTHS BETWEEN ELBOWS						
ACBI 7"	15°	DEVIATION	---	4 13/16" (122mm)	6 1/8" (156mm)	---	11" (280mm)	14 1/8" (359mm)	---	16 7/8" (429mm)	18 7/16" (468mm)	---	23" (584mm)	26 3/16" (665mm)
		HEIGHT	---	27 11/16" (703mm)	33 1/2" (851mm)	---	50 7/8" (1292mm)	65 1/2" (1588mm)	---	72 5/8" (1845mm)	78 7/16" (1992mm)	---	95 3/4" (2432mm)	107 3/8" (2727mm)
	30°	DEVIATION	---	9 3/8" (238mm)	12 3/8" (314mm)	---	21 3/8" (543mm)	27 3/8" (695mm)	---	32 5/8" (829mm)	35 5/8" (905mm)	---	44 5/8" (1134mm)	50 5/8" (1286mm)
		HEIGHT	---	25 3/4" (654mm)	31" (878mm)	---	46 1/2" (1181mm)	57" (1448mm)	---	66" (1676mm)	71 1/4" (1810mm)	---	86 7/8" (2207mm)	97 1/4" (2470mm)
*** NOTE : With the AC chimney, a starting length of 6" high must be used on top of the fireplace before installing an elbow***														

Table 4

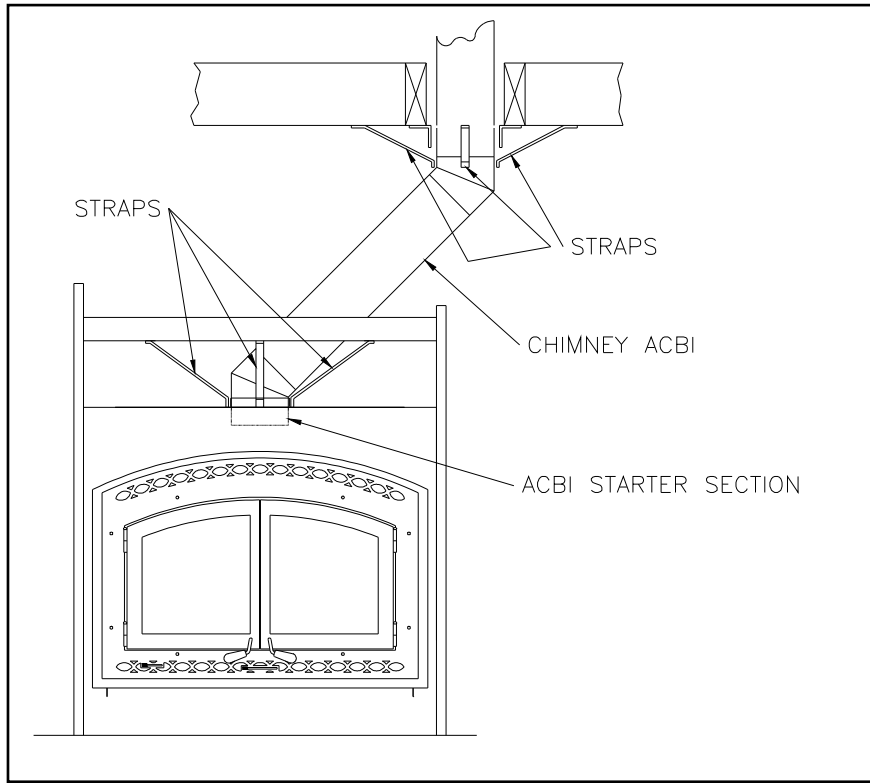

Figure 33

NOTE: IN COLD AREAS IT IS RECOMMENDED TO PROTECT THE CHIMNEY IN A INSULATED CHASE.

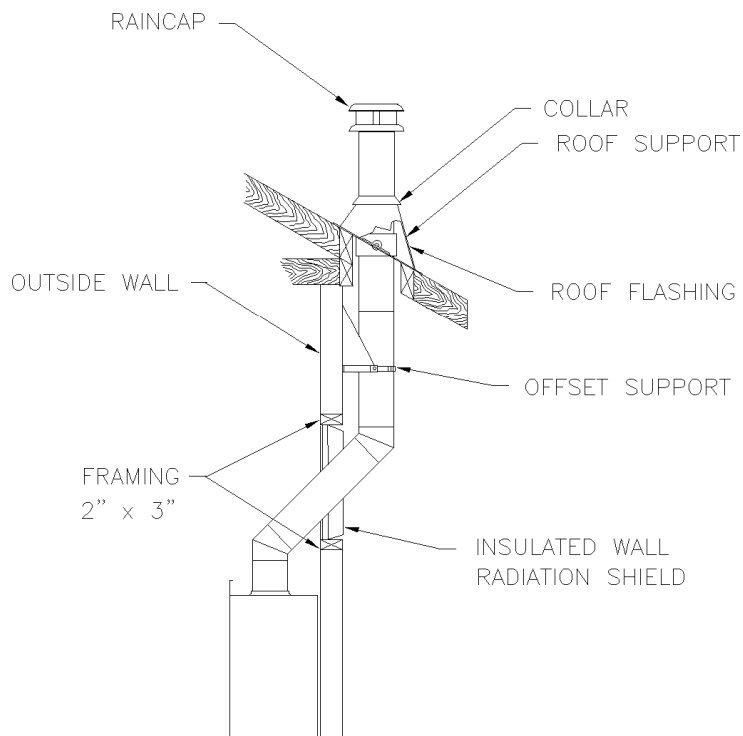

Figure 34

4.4 ANGLED WALL RADIATION SHIELD (XRSMI30, XRSMI45, AC10RSMI30)

When traversing a combustible wall with the chimney at a 30° or 45° angle, an angled firestop or wall radiation shield must be installed. Only one is required.

Note: 45° angle for Canada only

In cold climate locations, we recommend that you use the insulated wall radiation shield since it will maintain the home's thermal barrier.

XRSMI30, XRSMI45, AC10RSMI30		
CHIMNEY (7" dia.)	ANGLE	HOLE DIMENSION
Secure Temp ^{S2100+} Nova Temp ^{HT6000+} Secure Temp ^{GX} (US only)	30°	15" x 38 ¼" (380 mm x 972 mm)
Secure Temp ^{S2100+} Nova Temp ^{HT6000+}	45° Canada only	15" x 25 7/8" (380 mm x 657 mm)
ACBI	30°	17" x 42 ½" (432 mm x 1080 mm)

Tableau 5

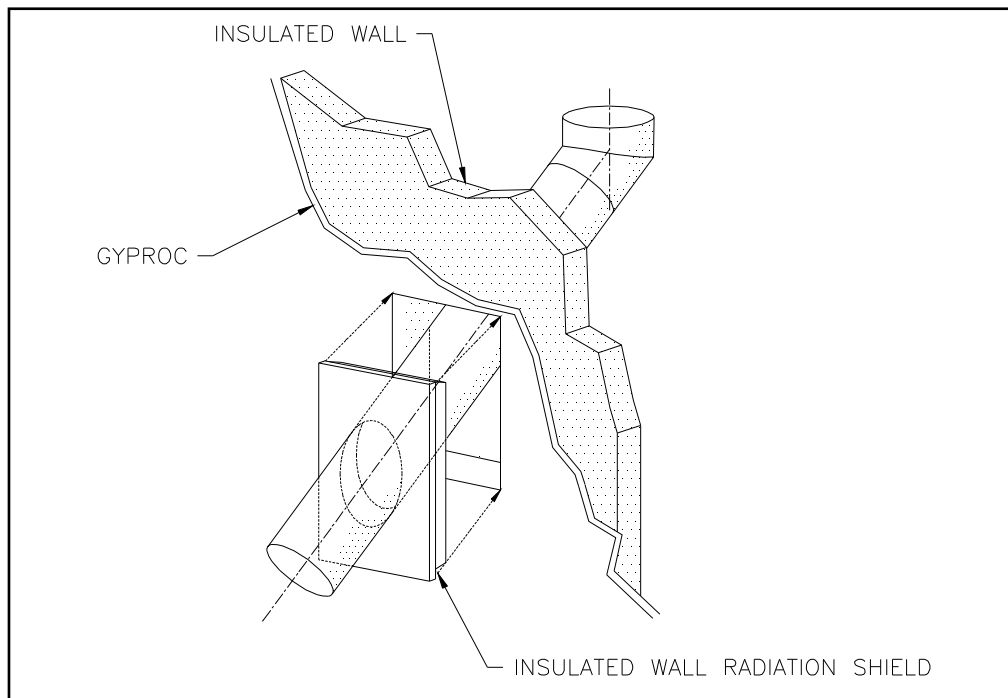

Figure 35

4.5 CHIMNEY SUPPORT INSTALLATION

UNIVERSAL ROOF SUPPORT

This support has three possible uses:

1. For Secure Temp^{S2100+} / Nova Temp^{HT6000+} / Secure Temp^{GX}, it must be used on a roof to support the chimney.
2. It may be used on a floor, ceiling or roof above an offset to support the chimney above the offset.
3. It may be used on a floor, ceiling or roof as a supplementary support when the chimney height exceeds 15 ft. (4.6 m.).

Table 6 gives maximum height of supported chimney.

NOTE: For the ACBI chimney, a support section (ACBI7SL) must be used every 30 ft. (9m) or an universal support every 20 ft. (6m) instead of the universal roof support (ST).

For roof support installation, refer to the instructions provided with the support.

UNIVERSAL OFFSET SUPPORT

This support is used to support the chimney above an offset. When the chimney offset is used to traverse a wall this support may be used on the wall to support the chimney. The maximum heights are given in Table 6. For offset support installation, refer to the instructions provided with the support.

CHIMNEY	MAXIMUM HEIGHT SUPPORTED	
	OFFSET SUPPORT	ROOF SUPPORT
7" diameter		
Secure Temp ^{S2100+} Nova Temp ^{HT6000+} Secure Temp ^{GX}	16 ft (5.49 m.)	18 ft (6.1 m.)
ACBI	40 ft (12.19 m.)	50 ft (15.20 m.)

Table 6

4.6 CHIMNEY CHASE AND MULTIPLE TERMINATIONS

For the purpose of this manual, a chimney chase is considered a part of the chimney system rather than part of a building. The termination must be placed a minimum of 18" (460 mm) above the chase.

For installations where more than one chimney is located in the same chase or within the same area, we suggest that their terminations be separated by at least 16" (410 mm) horizontally, and 18" (460 mm) vertically. This separation is to prevent smoke migrating from one chimney to another (see figure 36).

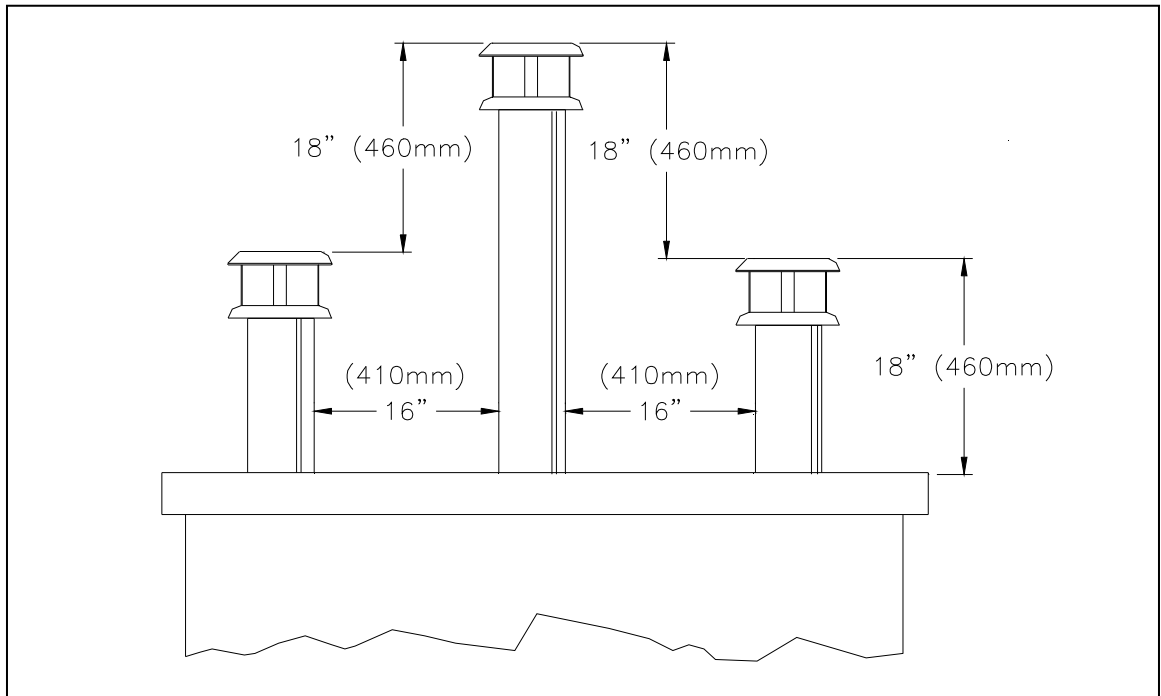

Figure 36

4.7 INSTALLATION INSTRUCTIONS FOR MASONRY APPLICATION

WARNING: Before starting the installation, the masonry chimney must be inspected by a qualified sweep.

The following requirements must be respected:

1. The chimney must be absolutely clear of any soot residue or creosote. Check for cracks, loose or missing bricks that could inhibit correct installation of the liner.
2. The clearance to combustibles must be a minimum of 1" between the outside of the masonry and any wood framing or loose insulation.
3. The chimney must be built in accordance with the current building code.
4. No other appliance can be connected to the same chimney.
5. The clearances to combustibles for the BISTMA30 or BISTMA connectors are 2" on the side and bottom and 16" at the top.
6. **The connector parts are not necessary if the connection between the insulated length and the stainless steel liner is done within the masonry chimney.**

Installation:

The chimney must be relined with a stainless steel liner model Tubinox™ or Projet SS of the same diameter as the outlet of the fireplace.

For connection at 45° angle, a special connector (BISTMA for the BIS TRADITION™ fireplace) must be used to connect the liner to the insulated chimney. For connection at 30°, use the BISTMA30 connectors.

Follow these steps:

- 1- Position the fireplace in its location. Temporarily install the S2100+ elbow on the top of the fireplace and, using a level, mark with an oval the location where the flue liner will enter the masonry chimney.
- 2- In the middle of the oval, drill a hole in the masonry chimney at 45° or 30°.
- 3- Increase the size of the hole until a 45° or 30° Tubinox liner elbow can be easily slipped through.
- 4- Slide the liner down from the top of the masonry chimney until you reach the hole level.
- 5- Slip through the hole a 45° or 30° liner elbow and connect it to the liner.
- 6- Add a small liner section to the liner elbow which will allow the liner to extend at least 12" (measured at the top of the liner) from the masonry chimney.
- 7- Seal the opening around the liner with high temperature refractory cement.
- 8- The next steps must be done in the following order :

See typical installation illustrated below

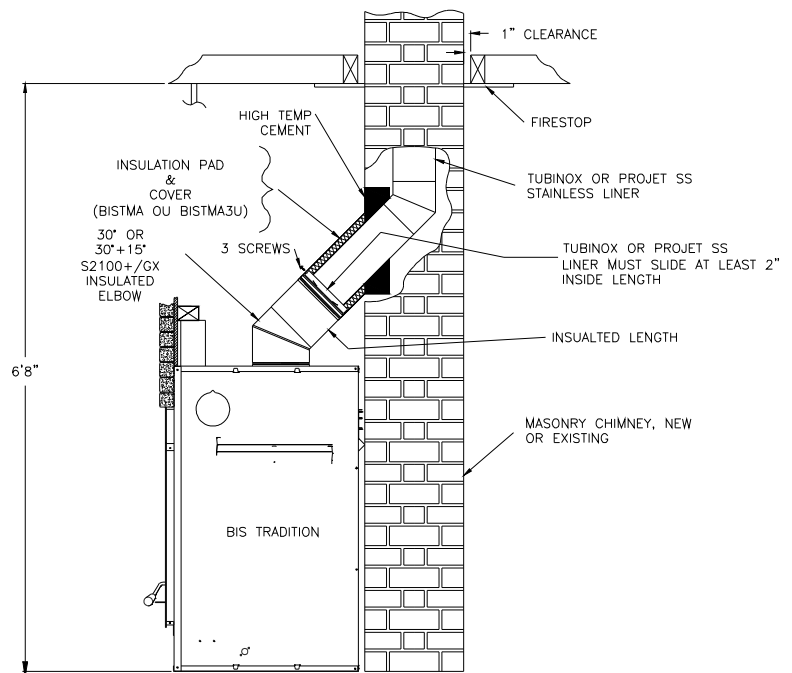

- A. Select the S2100+ length that will fit between the elbow and the liner so that it will slide at least 2" over the liner section. (You may need to cut the liner for a better fit).
- B. Take that section and the BISTMA OR BISTMA30 cover and slide it over the liner. Make sure you have enough opening to be able to install the S2100+ elbow without difficulty.
- C. Install the 45° or 30° elbow on the fireplace.
- D. Slide the length section back down on the elbow and twist lock the two together.
- E. Pull the cover down over the length and install the insulation pad over the liner; be careful to cover the liner completely.
- F. Slide back the cover over the insulation and fix it in place using the 3 metal screws supplied.

5. PARTS AND COMPONENTS LIST

ACBI Chimney

<u>Description</u>	<u>Part No.</u>
Lengths	7" dia.
12" length	ACBI7L12
18" length	ACBI7L18
36" length	ACBI7L36
48" length	ACBI7L48
15° elbow	ACBI7E15
30° elbow	ACBI7E30
Starter section	ACBI7SB
Offset starter section 30 deg.	ACBI7SB30
Rain cap	ACBI7CPR
Spark arrester screen	PE+
Supports	
Support section	ACBI7SL
Universal support	AC10SU
Firestop	
Firestop	ACBI7BF
Radiation shield	ACBI7RS
Attic radiation shield	ACBI7RSA
Telescopic attic radiation shield	ACBI7RST
Insulated wall radiation shield 30°	AC10RSMI30
Outside air kit (chimney) (flex, insulation, outside register and coupling)	ACZI
Outside air coupler for air kit	UACZI
Flat roof flashing	ACBI7F
Adjustable roof flashings	
1/12 - 7/12 (5° - 30°)	ACBI7FA
8/12 - 12/12 (30° - 45°)	ACBI7FB
Storm collar	AC10FC

Fireplace components :

<u>Description:</u>	<u>Part number:</u>
Black arch door	BTCBK
Gold plated arch door	BTCG
Nickel plated arch door	BTCBN
Hammered steel arch door	BTCMC
Black facade	BTFBK
Nickel plated facade	BTFBN
Gold plated facade	BTFG
Hammered steel facade	BTFMC
Outside air kit	UZI
45 deg adaptor for masonry	BISTMA
30 deg adaptor for masonry	BISTMA30
Outside air coupler to connect outside air UZI to fireplace	UZIAD

6. OPTIONS

Gravity kit:

Complete double ducting system including: 2 elbows 90°, 2 telescopic lengths, 2 grill supports and 2 black grills

Part No.:

7B30ZK-1

Black grill with support

7B30ZO

Brass grill for 7B30ZK-1

7B30ZGB

Elbow 90°, 8" dia.

7B26ZE90

Elbow 45°, 8" dia.

7B26ZE45

Telescopic length, 8" dia.

7B26ZLA

Adjustable length, 8" dia. (2" - 5")

7B26ZL2A

Radiation shield

7B26ZR

Central forced air kit:

Central forced air kit including: blower (BISZY), flex adaptor (BISAF), 2 clamps, variable speed control (VRUW), thermo-disk (VTU), fan to flexible pipe adapter (BISAVF), back draft damper (BISBD), aluminium tape

BISFWK-1

Fireplace to Flex adaptor and 2 clamps

BISAF

Flexible pipe 5" I.D. x 15 ft. Long

5FLEX15

Flexible pipe 5" I.D. x 30 ft. Long

5FLEX25

Blower 250 CFM for central forced air kit

BISZY

Blower variable speed control with decorative wall plate for (BISZY)

VRUW

Thermo-disk, on/off blower control for (BISZY)

VTU

Fan to flexible pipe adaptor

BISAVF

Heating and cooling thermostat

HCTW

Backdraft damper

BISBD

7. APPENDIX

SPECIFICATIONS

Weight	450 lbs
Height	49 3/8 in.
Width	46 1/4 in.
Depth	27 in.
Chimney weight S-2100+ (7" dia.) :	12 lb/ft.

CLEARANCE TO COMBUSTIBLES

The following clearances meet the minimum requirements for a safe installation

Side wall (fireplace front): 24" (457 mm) measured from the fireplace side

Ceiling: 6' 8" (2032 mm) measured from the base of the fireplace

Fireplace enclosure: Bottom: 0"
Side: 0" to spacers
Back: 0" to spacers

Top: Do not fill the space above the fireplace with any material (Except the wood framing. See figure 10)

Chimney: 2" (50 mm), except for through ceiling application, ACBI chimney, 1" (25 mm) clearance.

Mantel: 56" (1422 mm) measured from the base of the fireplace

REPLACEMENT PARTS

Front refractory bricks	PR-SR2421
Back refractory brick	PR-SR2415
Right side refractory bricks	Back PR-SR2417, Front PR-SR2419
Left side refractory bricks	Back PR-SR2416, Front PR-SR2418
Bottom refractory brick	PR-SR2422
Baffles top of firebox	PR-ISO2205
Top hearth insulation	PR-ISO2521
Timer	PR-SR2425
Secondary air tube (4)	PR-SR2379
Log retainers (2)	PR-B2CH
Fireplace blower	UZY5
Black metallic paint "Forrest Paint"	SBMB6309
Charcoal Paint (hammered façade)	PR-P6201
Decorative screw(8) & caps(16)	
Black	PR-SACBTFBK2
Gold	PR-SACBTFG2
Brushed Nickel	PR-SACBTFBN2
Fireplace top	PR-SR2363
Fireplace left side	PR-SR2394
Fireplace right side	PR-SR2365
Fireplace back	PR-SR2366
Wooden door handle	PR-SR1787
Right door rod and lock	PR-SR2543
Left door rod	PR-SR1785
Ceramic glass left	PR-SR2356G
Ceramic glass right	PR-SR2356D
Hinge set (door and fireplace)	PR-SR1800T
Gaskets:	
Around the glass (61 3/4")	PR-SR1685C
On the door frame (48 3/8")	PR-SR1823I
Between the doors (17 5/8")	PR-SR1823J
Door radiation shield kit	PR-SR2401KIT