

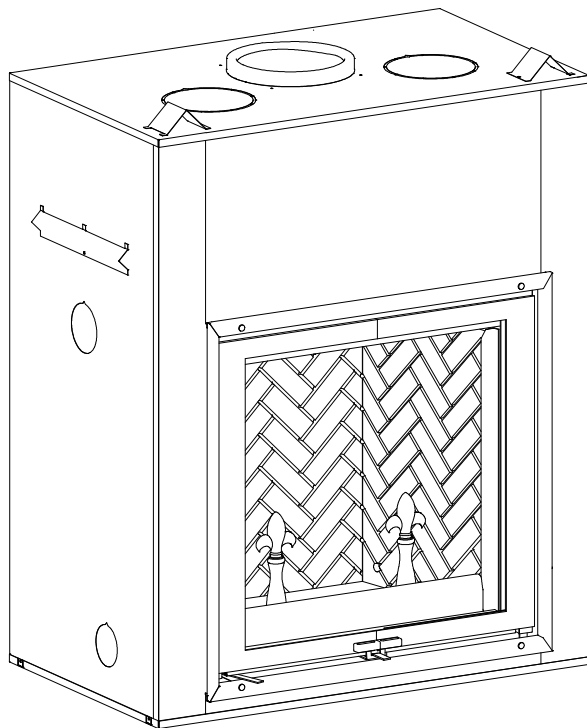

Le LAVAL



	<p style="text-align: center;">⚠ WARNINGS</p> <ul style="list-style-type: none"> • Hot! Do not touch! The glass and surfaces of this appliance will be hot during operation and will retain heat for a while after shutting off the appliance. Severe burn may result. • Carefully supervise children in the same room as appliance. • If small children are present in the home, it is recommended that this appliance be used with a fire screen kit.
	
	

Installation and Operating Instructions

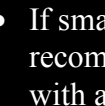
This installation manual will help you obtain a safe, efficient, dependable installation for your fireplace and chimney system. Please read and understand these installation instructions before beginning the installation or operating the fireplace.

CAUTION: Do not attempt to modify or alter the construction of the fireplace or its components. Any modification or alteration of construction may void the warranty, listings and approvals of this system. In that case, Security Chimneys International Ltd will not be responsible for damages.

Install the fireplace only as described in these instructions.

SAVE THESE INSTRUCTIONS FOR FUTURE REFERENCE

We recommend a certified installation by :

	<p>We suggest that our woodburning hearth products be installed and serviced by professionals who are certified in the U.S. by the National Fireplace Institute® (NFI) as NFI Woodburning Specialists or who are certified in Canada by Wood Energy Technical Training (WETT).</p> 
---	--

	<p>Listed to standards: ULC-S610, UL-127 Report # 3092554</p>
--	---

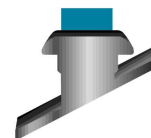

SECURITY CHIMNEYS INTERNATIONAL

2125 rue Monterey, Laval, Québec, Canada, H7L 3T6

TABLE OF CONTENTS

	Page
1. SAFETY RULES	1
2. CERTIFICATION LABEL	2
3. THE FIREPLACE	3
3.1 INTRODUCTION	3
3.1.1 Parts Required	
3.1.2 Additional Equipment (optional)	
3.2 OPERATING THE LE LAVAL FIREPLACE	4
3.2.1 Fuel	
3.2.2 First Fires	
3.2.3 Heat Output	
3.2.4 Combustion Control & Chimney Damper	
3.2.5 Accelerated Combustion	
3.2.6 Medium Combustion	
3.2.7 Building a Fire	
3.2.8 Refuelling For Best Performance	
3.2.9 Smoking – Causes And Troubleshooting	
3.3 MAINTAINING YOUR LE LAVAL FIREPLACE	9
3.3.1 Creosote	
3.3.2 Chimney Maintenance	
3.3.3 Dealing With a Chimney Fire	
3.3.4 Finish Door Casing Care	
3.3.5 Ashes	
3.3.6 Refractory Brick Replacement	
3.3.7 Door Installation	
3.3.8 Door Adjustment	
3.3.8.1 Door Opening Adjustment	
3.3.9 Bearing Maintenance	
3.3.10 Glass Care – Replacement	
3.3.11 Glass Care – Cleaning	
3.3.12 Gasket Replacement	
3.3.13 Andirons	
3.4 FIREPLACE INSTALLATION	14
3.4.1 Locating The LE LAVAL fireplace	
3.4.2 Hearth Extension Requirements	
3.4.3 Framing, Facing And Mantel	
3.4.4 Fireplace Blower (UZY5)	
3.5 HOT AIR DUCTING INSTALLATION (Optional)	20
3.5.1 Gravity Kit	
3.5.2 Central Forced Air Kit	
3.6 OUTSIDE AIR KIT	24
3.6.1 Outside Air Kit Installation	
4. THE CHIMNEY	25
4.1 CHIMNEY INSTALLATION NOTES	25
4.2 CHIMNEY INSTALLATION INSTRUCTIONS	26
4.3 OFFSET CHIMNEY INSTALLATION	29
4.4 ANGLED WALL RADIATION SHIELD	32
4.5 CHIMNEY SUPPORTS INSTALLATION	33
4.6 MULTIPLE TERMINATIONS	34
5. PARTS AND COMPONENTS LIST	35
6. OPTIONS	36
7. APPENDIX (Specifications, Clearances, Replacement Parts)	37

1. SAFETY RULES FOR OPERATING YOUR FIREPLACE MODEL LE LAVAL

Warning: The LE LAVAL fireplace **must be installed with an outside air kit intake**, which is included with the fireplace.

Warning: The fireplace must be operated with the doors fully opened or fully closed. If the doors are left partly opened, smoke may be drawn into the room. If the unit is operated with the doors fully opened, the fire screen must be used.

Warning: For spectacular fire view and optimum efficiency of your fireplace, we recommend that the wood be placed as far back as possible in the fireplace.

- When cleaning the fireplace, the ashes should be placed in a metal container with a tight fitting lid. The closed container of ashes should be placed on a non-combustible floor or on the ground outside the house, pending final disposal. If the ashes are disposed of by burial in soil or otherwise locally dispersed, they should be retained in the closed container until all cinders have thoroughly cooled.

Caution: Do not block the hot air vents on the fireplace as this will cause the fireplace to overheat.

Caution: Never use gasoline, kerosene, charcoal lighter fluid or similar liquids to start or rekindle a fire in this fireplace. Keep all such liquids well away from the fireplace at all times. Do not burn coal. The sulphur in coal will corrode the chimney.

Caution: Keep combustible materials at least 48” (1.2 m) away from the front of the fireplace opening.

Caution: Never leave children unattended when there is a fire burning in the fireplace.



Caution: Use only untreated wood. Wood protectors, metallic paper, coal, plastic, waste, sulphur and/or oil will damage the fireplace.

Caution: Do not use the LE LAVAL fireplace as an incinerator to burn paper, cardboard or construction material such as pressed wood, plywood or lumber.

WARNING: THIS FIREPLACE HAS NOT BEEN TESTED WITH AN UNVENTED GAS LOG SET OR A FIREPLACE INSERT. TO REDUCE RISK OF FIRE OR INJURY, DO NOT INSTALL AN UNVENTED GAS LOG SET OR A FIREPLACE INSERT INTO THIS FIREPLACE.

2. CERTIFICATION LABEL

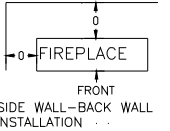
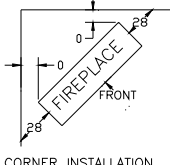
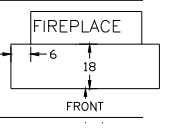
Note: the certification label is located in the lower right corner under the finishing trim.

 <p>LISTED FACTORY BUILT FIREPLACE FOYER PRÉFABRIQUÉ HOMOLOGUÉ</p> <p>TESTÉ TO: ULC S610 M87 TESTÉ SELON: UL 127 7th ed. May 16, 1996</p> <p>MODÈLE/MODEL: LAVAL</p> <p>LAVAL-</p>	<p>CLEARANCES TO COMBUSTIBLES: SIDE WALL: 24" (610 mm) (FROM DOOR EDGE)</p> <p>MANTLE: 59" (1422 mm) (ABOVE BASE OF THE FIREPLACE)</p> <p>BACK WALL AND FIREPLACE SIDE: 0" (0 mm) (FROM SPACERS)</p> <p>CEILING HEIGHT: 8' (2438 mm) (ABOVE THE BASE OF FIREPLACE)</p> <p>CHIMNEY: 2" (51 mm)</p>	<p>FUEL: WOOD ONLY</p> <ul style="list-style-type: none"> • NON COMBUSTIBLE HEARTH EXTENSION MUST BE INSTALLED AT FRONT OF UNIT EXTENDING 18 in (457 mm) AT FRONT AND 6 in. (152 mm) TO SIDES OF DOOR OPENING. • THIS FIREPLACE HAS NOT BEEN TESTED WITH UNVENTED GAS LOG SET. TO REDUCE RISK OF FIRE OR INJURY DO NOT INSTALL AN UNVENTED GAS LOG SET INTO THE FIREPLACE. • ELECTRICAL RATING: 115 V, 60 Hz • CAN BE CONNECTED TO A MASONRY CHIMNEY AS DESCRIBED IN THE INSTALLATION INSTRUCTIONS. • COMPONENTS USED WITH THE FIREPLACE MUST BE LISTED. SEE LIST IN THE INSTALLATION INSTRUCTIONS. • REPLACE GLASS WITH CERAMIC GLASS 5 mm THICK. • FOR SAFE OPERATION INSTALL IN ACCORDANCE WITH THE MANUFACTURER'S INSTRUCTIONS. • CAUTION: COMBUSTION AIR OPENING MUST NOT BE OBSTRUCTED. • DO NOT OVERFIRE THE FIREPLACE. • OPERATE THE FIREPLACE WITH DOORS FULLY OPEN OR FULLY CLOSED ONLY. <p>CONTACT YOUR LOCAL BUILDING OR FIRE OFFICIALS ABOUT RESTRICTIONS AND INSTALLATION INSPECTIONS IN YOUR AREA.</p>	<p>COMBUSTIBLE: BOIS SEULEMENT</p> <ul style="list-style-type: none"> • UN TABLIER NON COMBUSTIBLE DOIT ÊTRE INSTALLÉ À L'AVANT DU FOYER EXCÉDANT DE 18 po. (457 mm) À L'AVANT ET 6 po. (152 mm) DES CÔTÉS DE L'OUVERTURE DES PORTES. • MAINTENIR LES MEUBLES ET AUTRES OBJETS À UNE DISTANCE SÉCURITAIRE DU FOYER. • ALIMENTATION ÉLECTRIQUE : 115V, 60 Hz • UTILISER SEULEMENT AVEC UNE CHEMINÉE 10 po. (254 mm) DE DIAMÈTRE, MODÈLE ASHT+, GASHT, HT6103+, AC HOMOLOGUÉE. • PEUT ÊTRE RACCORDÉ À UNE CHEMINÉE DE MAÇONNERIE TEL QUE DÉCRIT DANS LE MANUEL D'INSTALLATION. • LES COMPOSANTES UTILISÉES AVEC LE FOYER DOIVENT ÊTRE HOMOLOGUÉES. VOIR LA LISTE DANS LE MANUEL D'INSTALLATION. • REMPLACER LA VITRE AVEC UN VERRE CÉRAMIQUE DE 5 mm D'ÉPAISSEUR. • POUR UNE UTILISATION SÉCURITAIRE, INSTALLER CONFORMÉMENT AUX DIRECTIVES DU FABRICANT. • ATTENTION : NE PAS OBSTRUER LES ARRIVÉES D'AIR COMBURANT. • NE PAS FAIRE SURCHAUFFER LE FOYER. • LES PORTES DU FOYER DOIVENT DEMEURER TOTALEMENT OUVERTES OU TOTALEMENT FERMÉES LORSQUE LE FOYER FONCTIONNE. 	<p>INSTALL AND USE ONLY IN ACCORDANCE WITH THE MANUFACTURER'S INSTRUCTIONS AND LOCAL BUILDING CODES.</p> <p>CHIMNEY TYPE: USE ONLY LISTED CHIMNEY MODEL GASHT, ASHT+, HT6103+, AC, dia. 10 in..</p> <p>SPECIAL METHODS ARE REQUIRED WHEN PASSING THROUGH A WALL OR CEILING. SEE INSTRUCTIONS AND BUILDING CODES.</p> <p>PREVENT CREOSOTE FIRE: INSPECT CHIMNEY CONNECTOR AND CHIMNEY FLUE MONTHLY AND CLEAN IF NECESSARY.</p> <p>DO NOT OVERFIRE. IF DOME OR CHIMNEY CONNECTOR GLOWS YOU ARE OVERFIRING.</p> <p>KEEP FURNISHINGS AND OTHER COMBUSTIBLE MATERIALS A CONSIDERABLE DISTANCE AWAY FROM APPLIANCE.</p>	<p>INSTALL WITH MINIMUM CLEARANCES TO WALL AS SHOWN IN INCHES</p>  <p>FRONT SIDE WALL-BACK WALL INSTALLATION</p>  <p>CORNER INSTALLATION</p>	<p>FLOOR PROTECTOR MINIMUM DISTANCE FROM OPENING IN INCHES</p>  <p>FRONT</p> <p>HEARTH EXTENSION MATERIAL:</p> <ul style="list-style-type: none"> - 1" THICKNESS NON COMBUSTIBLE MATERIAL - OR EQUIVALENTS <p>NP280 REV. #1</p>
<p>SECURITY CHIMNEYS INTERNATIONAL LTD</p>  <p>CHEMINÉES SÉCURITÉ INTERNATIONALE LTÉE</p> <p>LAVAL, QUÉBEC, CANADA.</p> <p>DATE OF MFG</p> <p>1 2 3 4 5 6 7 8 9 10 11 12</p> <p>YEAR</p> <p>2004 05 06 07 08 09 10 11 12</p>						

3. THE FIREPLACE

3.1 INTRODUCTION

The LE LAVAL fireplace is a mid-efficient, heat radiating fireplace. You will receive a lifetime of comfort and enjoyment from your fireplace provided it is installed, maintained and operated properly.

- Please read these instructions and retain this manual for future reference.
- Before beginning the fireplace installation, consult the local authorities to obtain your building permit and check your local building codes. **Install the fireplace only as described in these instructions and using only Security Chimneys International components.**
- When planning a fireplace installation the following information must be determined before beginning.
 1. Where the fireplace is to be installed.
 2. The configuration of the chimney.
 3. Optional components installation (fan, hot air ducting, etc).
 4. Electrical wiring.
 5. framing and finish details.

3.1.1 Parts Required

- Fireplace model LE LAVAL
- 10" diameter chimney model Secure Temp^{ASHT+}, Nova Temp^{HT6103+} or AC manufactured by Security Chimneys International only, including:
 - Chimney lengths
 - Elbows (where necessary)
 - Associated components as per these installation instructions
- Outside air kit. (included)

3.1.2 Additional Equipment (optional)

- 5" flexible venting system (central forced air kit) (see section 3.5.2)
- UZY5 fan. The fan installation requires that an electrical connection of a 120v electrical box located outside the fireplace be made prior to moving the fireplace in its final position. (sect. 3.4.4)
- Gravity venting system (see section 3.5.1)

3.2 OPERATING THE LE LAVAL

3.2.1 *Fuel*

The LE LAVAL fireplace is designed to work best when fueled with seasoned cordwood. Hardwoods are preferred to softwoods since the energy content of wood is relative to its density. Hardwoods will result in a longer burning fire and less frequent refuelling. A moisture content of 15% to 20% (seasoned) is recommended. Wood that has been cut and split and let to dry under a cover for a period of one year will usually meet that criteria. Omit excessively wet wood will be difficult to burn and will result in lower efficiency, increased creosoting and deposits on the glass and in the chimney. Omit excessively dry wood will burn well but will also have higher emissions and shorter burning time.

Do not burn scrap or garbage, treated wood or wood such as driftwood from the ocean which has been exposed to salt or other chemicals. Salt or chemicals can corrode the firebox and chimney. Do not burn large amounts of paper, cardboard, Christmas tree branches or building construction materials. Intense firing with these materials may overheat the fireplace, causing damage to the unit, a fire or even possibly igniting a chimney fire if the chimney is creosoted.

Processed firelogs can be used. Refer to firelog warnings and caution markings on packaging prior to use.

3.2.2 *First Fires*

Before using the fireplace make sure to remove the plastic wrapping on the door. Remove all remaining glue with mild soap. Make sure the doors are properly adjusted, thus avoiding colour change to finish due to overheat.

The first 5 or 6 fires should be small fires of short duration (about 30 to 60 minutes). This will help cure the refractory bricks. The first fires may produce slight smoking due to drying of the paint and steel and any dust accumulated on the fireplace will burn off at this time. It may set off a smoke alarm located in the same room. For this reason the room should be well ventilated for the first few fires.

3.2.3 *Heat Output*

The LE LAVAL fireplace is a mid-efficiency fireplace. In spite of the heat that the LE LAVAL fireplace can deliver, it should not replace the main source of heat in your home. This fireplace will bring extra warmth and ambiance to your home by distributing its heat as describe further in the manual.

<p><i>FOR MAXIMUM HEAT OUTPUT, WE STRONGLY RECOMMEND THE INSTALLATION OF HOT AIR DUCTING SYSTEM (SECTION 3.5).</i></p>

3.2.4 Combustion Control & Chimney Damper

LE LAVAL fireplace includes a combustion air control that sets the flow of air entering the firebox and control the fire. The fireplace also includes a chimney damper that is not a combustion control. The chimney damper must always be in fully open position when the fireplace is used and should be closed only when all ashes are cold.

The chimney damper is controlled by the handle inside the firebox (fig. 1-A). It is in closed position when the handle is visible (front) and in the open position when not visible (pushed back). The combustion air damper is controlled by the lower handle (fig. 1-B). The control can be moved from open position at left all the way to the close position at right.

This air combustion control should be in the closed position when the fireplace is not in operation. This will minimize air infiltration. **The combustion air control should be opened before opening the doors to minimize the possibility of back draft coming into the room** (figure 1-A) More details are available in section 3.2.9.

Warning: The air combustion control must be in the open position if the fireplace is operated with the doors open.

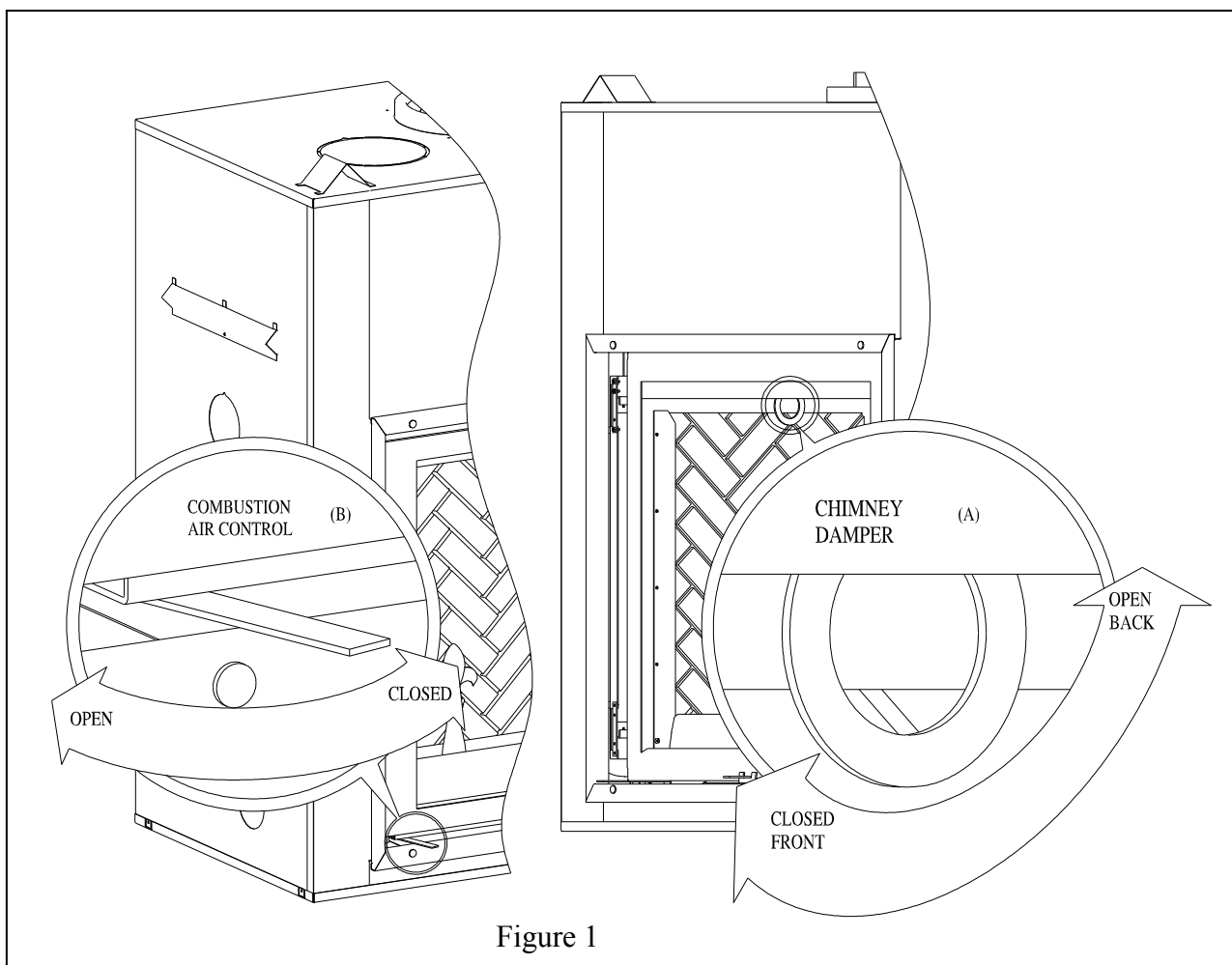

3.2.5 Accelerated Combustion

The maximum heat output for the LE LAVAL fireplace is achieved by burning with the door closed and the combustion air opened. However, it will be necessary to reload with wood every hour. **This is the least efficient method of burning the LE LAVAL fireplace.** Use caution when burning with the combustion air control wide open. Only burn cordwood in this manner. Small dry pieces of softwood and construction scraps will burn very intensely using this method and may damage the firebox.

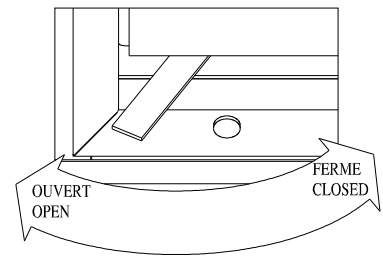

3.2.6 Medium Combustion

This is the recommended mode of operating the LE LAVAL fireplace and should be the one normally used since it will deposit the least amount of creosote on the glass and in the chimney. The combustion air control must be 3/4 closed. The precise setting will depend on many factors, including chimney length and the moisture content of the wood.

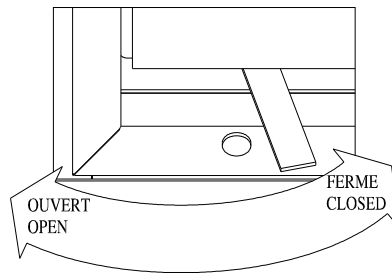

For instance, a long chimney will necessitate closing the damper more. To obtain the proper combustion, close the damper completely, then open it about 1/4" to 1/2". Three medium size pieces of cordwood burning on a bed of hot coals will burn about 1-2 hours. Softwoods may be burned using this method but the combustion time will be substantially reduced.

FOR MAXIMUM HEAT OUTPUT, WE STRONGLY RECOMMEND THE INSTALLATION OF THE OPTIONAL HOT AIR DUCTING SYSTEM.

3.2.7 Building a Fire

- A) To start a fire, place several crumpled up balls of newspaper in the firebox. Place small dry pieces of kindling on top of the paper, criss-crossing the kindling so that there are air spaces in between. The kindling should be placed at the center of the firebox so as to allow for sufficient air circulation.
- B) Open the dampers and light the newspaper. Leave the doors partially opened (1 to 2 inches) to facilitate the start-up.
- C) Once kindling fire is well established, cordwood can be added. Close the doors and leave the combustion air control open in accelerated combustion position
- D) When the fire burns well set the primary control to the desired burn level.

The unit will burn best with 2-3 pieces of cordwood spaced 1 to 2 inches apart and allowing air to get under the fuel. Criss-crossing or arranging the fuel so that air can get underneath will help the fire to get started easily. The unit should be operated with the air control fully open long enough to get the cordwood well ignited.

WARNING: LE LAVAL was designed to allow a spectacular view of the fire. LE LAVAL fireplace should never be filled in excess (five big logs and more). Excessive fire could damage the fireplace's hearth and refractory brick and void the warranty.

3.2.8 *Refuelling For Best Performance*

To reload the LE LAVAL fireplace:

- A) Completely open the combustion air control (see figure 1).
- B) Open the doors about 1” and wait 5 seconds until the airflow has stabilized. Then open the doors completely, put the logs in and close the doors.
- C) Set the combustion air control to the desired burn level.

Note: For a spectacular fire and to optimize the fireplace efficiency, we recommend that the wood be placed in the fireplace as far back as possible.

It may be necessary to close any optional fan(s) in operation during the refuelling process in order to minimise smoking in the room. Wait 15 to 30 minutes before turning the fan(s) back on to ensure successful rekindling.

3.2.9 *Smoking – Causes and Troubleshooting*

To reduce the likelihood of smoke coming into the room when opening the door, set the combustion air controls to the left (“Accelerated Combustion”) before opening the door. Your fireplace has been designed and tested to provide smoke free operation. Occasionally, there may be a small amount of smoking upon lighting the fire until the chimney heats up. If the fireplace continues to smoke it is probably for one of the following reasons:

A. The doors are partially opened

When you open the doors, open them completely.

B. Negative pressure in the house

A fire needs air to burn. This air must be replaced through the outside air duct (sect. 3.6 p. 25). When operating the LE LAVAL fireplace, open a nearby window temporarily to check if there is adequate air supply replacement.

C. Fans operating (e.g.: range hood)

Fans such as range hoods or bath fans draw air out of the house and may actually cause a negative pressure in the house. Turn off all fans and open a nearby window to determine if this is the cause of the problem.

D. Wet wood

Wet or tarred wood will smoulder and smoke instead of burning properly. Your dealer can help you determine if you have properly seasoned wood for burning.

E. Dirty or blocked chimney

Check to make sure the chimney is clear and clean. If dirty call a certified chimney sweep or use a properly sized chimney brush to clean

F. Chimney not long enough

The minimum chimney height is 15 ft. not including the fireplace height. The chimney must extend at least 3 feet (915 mm) above its point of contact with the roof and at least 2 feet (610 mm) higher than any roof or wall within 10 feet (3 m) of it. When installed with offsets, the minimum chimney height is 18 ft. Additional height will increase draught and will decrease the tendency to smoke.

G. Poor chimney draft

With no fire, there should be sufficient draft to exhaust cigarette smoke introduced under the baffle. Chimneys installed against an outside wall without protection may generate back draft problems which will cause start-up problems. To prevent this, open a nearby window; roll up a piece of paper, light it and hold it in the upper part of the firebox to warm up the chimney. Wait until the draught is sufficient, then start the fire.

H. Blower for central forced air kit

Make sure that the blower is at the "off" position when you open the fireplace door for reloading.

3.2.9 Gas Log Installation

This fireplace is designed to allow the installation of a gas burner. In such a case, the installation must conform with the National Gas Code ANSI Z223.1 and Z21.60. **Warning:** When using a gas burner, it is mandatory to keep the chimney outside air register opened.

This fireplace has provision for the installation of a gas pipe and is intended only for connection to a decorative gas appliance incorporating an automatic shutoff device and complying with ANSI Z21.60-M96/CGA 2.26-M96, Standard for Decorative Gas Appliances for Installation in Solid-Fuel Burning Fireplaces (reference Clause 4.1.3 T).

1. Remove the 1 in. knockout on the right side of the fireplace and on the right side refractory.
2. Drill a one inch hole in the hearth right side coaxial to the refractory opening.
3. Assemble a rigid 3/8" N.P.T. iron pipe with two 90° elbows. Make sure to have 5 11/16 " clearance between the two pipes. (fig. A)
4. Through the hearth bottom or back openings insert the mounted pipe through the side of the firebox and the firebrick. Make sure the top elbow is as close as possible to the hearth to keep a minimum clearance to the retractable door.
5. Insert a pipe through the 1 in. exterior knockout and fix it to the 90° elbow already in place.

Note : In some regions, the use of a flexible gas pipe is allowed. Consult your local authority.

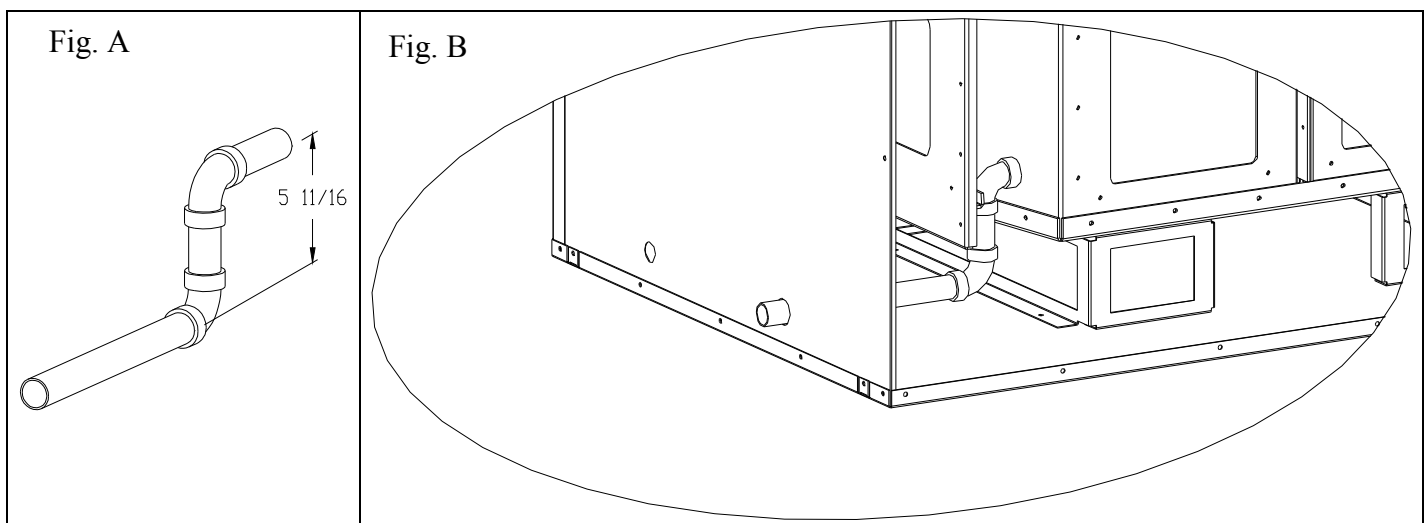

3.3 MAINTAINING YOUR LE LAVAL FIREPLACE

3.3.1 *Creosote*

When wood, especially wet wood, is burned slowly without a flame, it produces tar and other organic vapours which combine with expelled moisture to form a black deposit called creosote which accumulates on the flue lining. If ignited, this creosote makes an extremely hot fire. When the creosote accumulation is large, a creosote fire in the chimney can damage the chimney and overheat the surrounding wood framing. Creosote formation in a chimney can be minimized by making sure there is always visible flame burning, avoid smouldering fires and by proper refuelling techniques.

3.3.2 *Chimney Maintenance*

Regular chimney inspection and maintenance combined with proper operation will prevent chimney fires. Keep your chimney clean. Do not allow more than 1/16" creosote build up in your chimney. The amount of creosote will depend on variables such as frequency of use and type of fire. We recommend that you:

- A. Initially inspect the chimney system weekly. From this, you will learn how often it will be necessary to clean your chimney.
- B. Have your chimney cleaned by a qualified chimney sweep. If you wish to clean it yourself, we recommend using a stiff plastic or non-metallic brush. If a metal brush is used, its size should be slightly smaller than the flue to avoid damaging the chimney. Do not use a brush that will scratch the stainless steel interior of the chimney.

Warning: The chimney damper must be opened when sweeping the chimney to avoid ash and creosote accumulation in the fireplaces air circulation area.

- C. Do not expect chemical cleaners to keep your chimney clean. The rain cap can be removed for inspection and/or cleaning of the chimney.

3.3.3 *Dealing with a Chimney Fire*

Regular chimney maintenance and inspection can prevent chimney fires. If you have a chimney fire, follow these steps:

1. IMPORTANT: Close the fireplace door and the combustion air controls; this will stifle the fire.
2. Alert your family of the possible danger.
3. If you require assistance, alert your fire department.
4. If possible, use a dry chemical fire extinguisher, baking soda or sand to control the fire. Do not use water as it may cause a dangerous steam explosion.
5. Ensure that sparks and hot embers coming out of the chimney are not igniting the roof.
6. Do not use the fireplace again until your chimney and fireplace have been inspected by a qualified chimney sweep, your dealer, or a fire department inspector.

3.3.4 Door Frame Finish Care

Use a glass cleaner and a soft cloth to polish the casing. Do not use abrasives such as steel wool, steel pads or an abrasive polish for they may scratch the frame's finish.

3.3.5 Ashes

Remove ashes only when the fire is out and the ashes are cold (24 to 48 hours after the fire is out). Always use a metallic container to dispose of the ashes.

3.3.6 Refractory Brick Replacement

The intense heat of the fire will normally cause hairline cracks in the refractory brick. These cracks can be minimized by proper curing as described in section 3.2.2. They will not normally diminish the effectiveness of the refractory brick. If large cracks develop, then the refractory should be replaced. To replace the refractory bricks, follow these steps:

1. Remove the front refractory bricks
2. Remove the andirons
3. Remove the side refractory supports
4. Remove the side refractory bricks
5. Remove the back refractory brick
6. Remove the bottom refractory brick

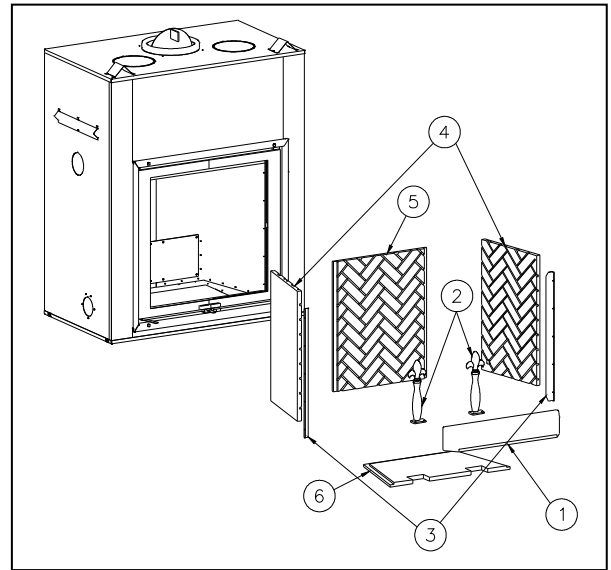
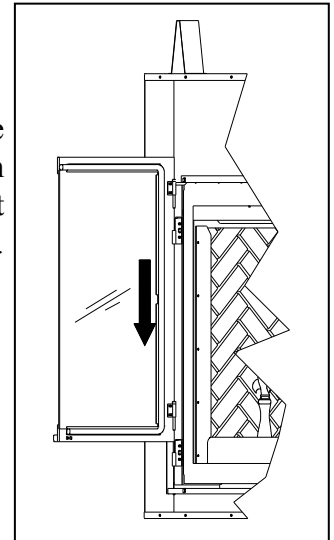

Figure 2

To install the new refractory bricks, follow the above steps in reverse.

3.3.7 Door Installation

The doors of the Le Laval fireplace are factory installed. To remove the doors, remove the finishing trim then simply pull them up from the hinges. The door adjustment has been set at the factory. If the fit is still not perfect, you can adjust the door using the hinge screws. (See fig 6-1)



3.3.8 Door Adjustment

The doors are factory adjusted for proper air tightness and fit. They may need to be re-adjusted if the alignment has shifted in freight.

To readjust the door side to side position, unscrew the fireplace or the door hinges. Move the doors side to side until the top of the two doors are aligned (figure 6A). The gaskets' air-tightness can be adjusted using the adjustment screw located on the slider stoppers. Turning the screws clockwise will shorten the travel of the slider and increase the pressure on the door side gaskets. This may lead to the doors being harder to lock, so a good adjustment must be found between a good gasket seal and easy door lock (see figure 6B, balloon 1).

The door lock can also be adjusted. Remove the front refractory brick and loosen the two screws in the middle front of the firebox bottom. Push or pull on the handle of the door lock. Pushing the handle will tighten the door seal in the center of the fireplace. (Figure 6C).

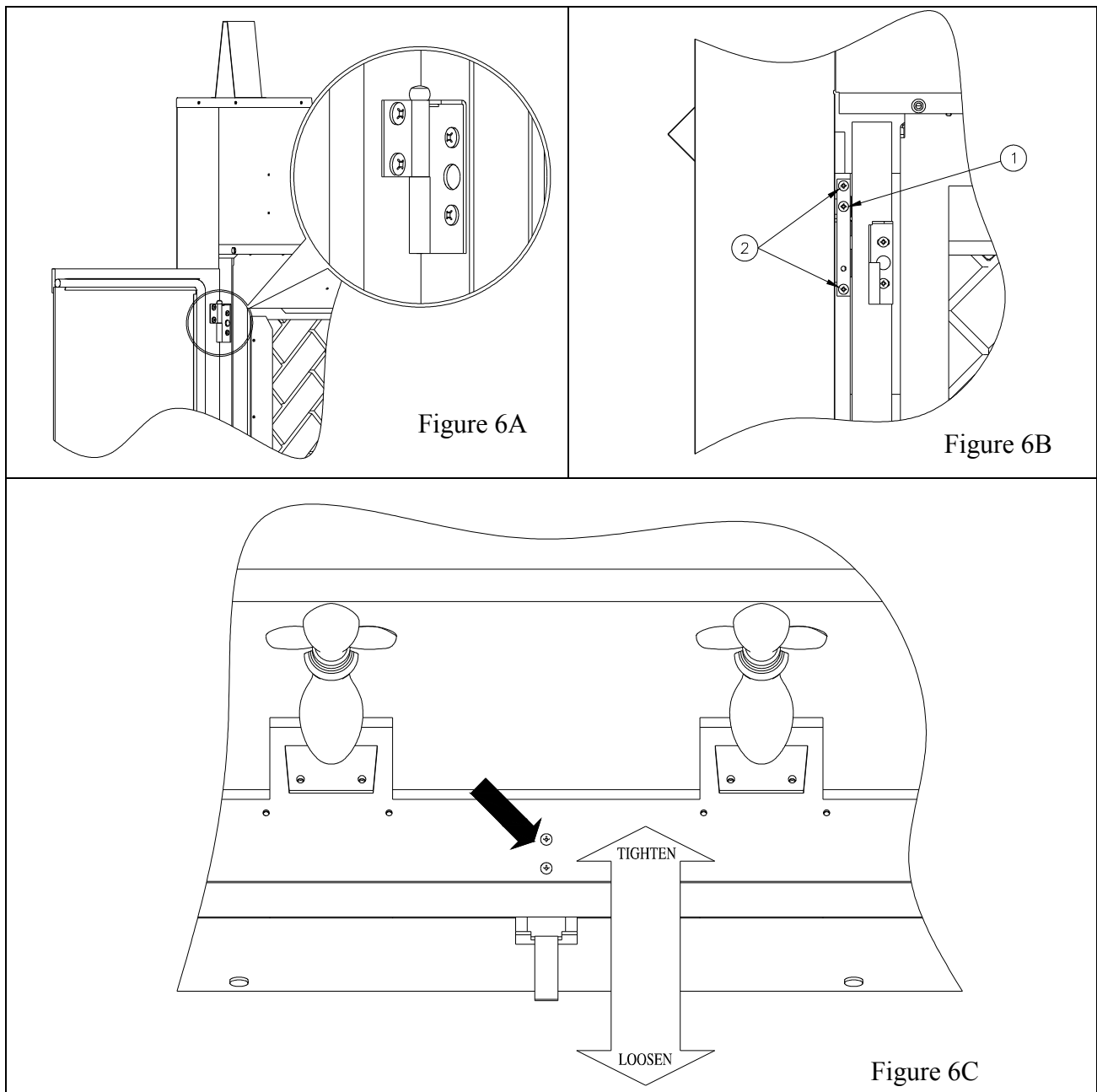

3.3.8.1 Door Opening Adjustment

The doors opening angle can be adjusted. This allows the doors to slide in the fireplace without interference or friction with the finishing facing, which could damage the paint. The screws located under the bottom hinges (figure 6E) are used as door opening stops. Tightening or loosening these screws will keep the door handle from hitting the finishing facing and won't allow friction between door gasket and hearth when the door is fully pushed in the fireplace.

3.3.9 Bearing Maintenance

The doors are assembled on retractable sliders using roller bearings for easy movement. LE LAVAL fireplace has been designed to ensure that bearing maintenance is easy. Remove the decorative facing by unscrewing the four decorative caps and the four screws holding the facing. Remove the doors by lifting them up from the female hinges (section 3.3.7). Remove the slider stoppers (fig. 6B, balloon 2) and take the slider bearing assembly out of the fireplace. Unscrew the nuts to change the bearings (fig 6D). Original bearing contains no grease to resist heat. Adding grease or changing bearings with greased bearing may cause a malfunction of the slider. Please use Security Chimneys Int'l replacements parts only. (see page 38 for part #)

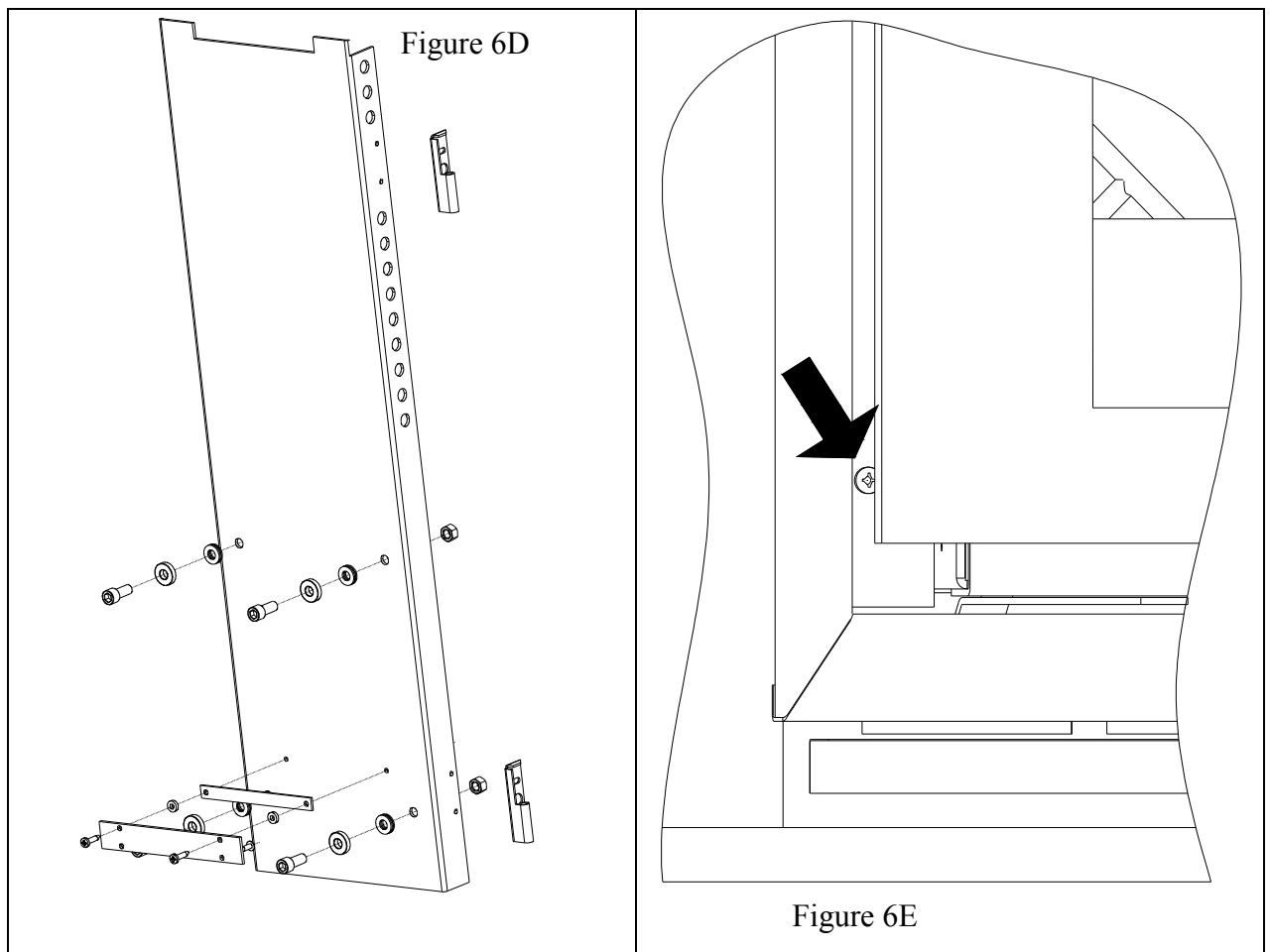

3.3.10 Glass Care - Replacement

The glass used for the LE LAVAL fireplace is a high temperature ceramic glass (1400°F). If the glass breaks or cracks, it must be replaced with an identical ceramic glass. Tempered glass or ordinary glass will not withstand the high temperatures of the LE LAVAL fireplace. Replacement glass should be purchased from a Security Chimneys International dealer (see “Replacement Parts”, Section 5).

Do not operate the unit with cracked or broken glass.

3.3.11 Glass Care - Cleaning

The LE LAVAL fireplace is designed to keep the glass clean under normal operating conditions. If the LE LAVAL fireplace is operated continuously with the combustion air controls closed, the glass will tend to get dirty unless the fuel, firebox and glass are maintained at hot temperatures (see section 3.2.10). To clean the glass, there are a number of specially designed cleaners to remove creosote. Your authorized Security dealer can recommend a suitable cleaner. Regular household glass cleaners will not clean creosote. Do not use abrasives such as steel pads, steel wool or oven cleaner as they will scratch the glass.

DO NOT USE CHEMICAL GLASS CLEANERS ON PAINTED SURFACES AS IT MAY CAUSE THE PAINT TO PEEL.

CAUTION : Do not allow window cleaner to get in contact with the door gasket or paint on facade or door. Once closed, contact of the glass cleaner with the fireplace facade can provoke paint peeling off.

3.3.12 Gasket Replacement

Remove the doors from the unit (see section 3.3.7) and lay them on a clean nonabrasive surface. To replace the gasket, first remove all of the old gasket and gasket cement. Make sure that the surface is totally clean before applying new cement (a high temperature silicone caulking rated at 500°F, 260°C, is suitable) or adhesion problems may result. Apply gasket cement to the gasket channel and install the new gasket. This replacement part is available from your Security dealer in the following dimensions:

<u>Gasket</u>	<u>Part #</u>	<u>Length</u>	<u>Quantity</u>	<u>Dimensions</u>
Door perimeter	PR-SR1823N	58 3/4"	2	5/8" dia

3.3.13 Andiron

Le Laval fireplace is equipped with andirons designed to keep logs from falling in the doors. It must be replaced only by Security Chimneys International andirons available from your dealer. No other andirons, log retainer or log support is sold or recommended by Security Chimneys International.

3.4 FIREPLACE INSTALLATION

3.4.1 *Locating the LE LAVAL fireplace*

The best location to install your fireplace is determined by considering the location of windows, doors, and the traffic flow in the room where the fireplace is located, allowing space in front of the unit for the hearth extension and the mantel, and taking into consideration the location of the hot air ducts (optional), outside air kit and chimney. If possible, you should choose a location where the chimney will pass through the house without cutting floor or roof joists (see fireplace dimensions on page 13).

Usually, no additional floor support is needed for the fireplace. The adequacy of the floor can be checked by first estimating the weight of the fireplace system. Weights are given in the appendix. Next, measure the area occupied by the fireplace. Note the floor construction and consult your local building code to determine if additional support is needed.

The LE LAVAL fireplace may be installed directly on the floor or on a raised base but a minimum of 8' measured from the base of the appliance to the ceiling is required.

When selecting the location, the chimney outlet position and the direction of the wind are important factors affecting the chimney performance. To allow a maximum draft and to reduce wind turbulence, the chimney must:

- Penetrate the highest part of the roof.
- Be installed as far as possible of roof offsets, trees or any other obstructions that may cause wind turbulence and back drafts in the chimney.
- The least amount of offsets (elbows) possible.

NOTE: A maximum of 2 offsets is allowed

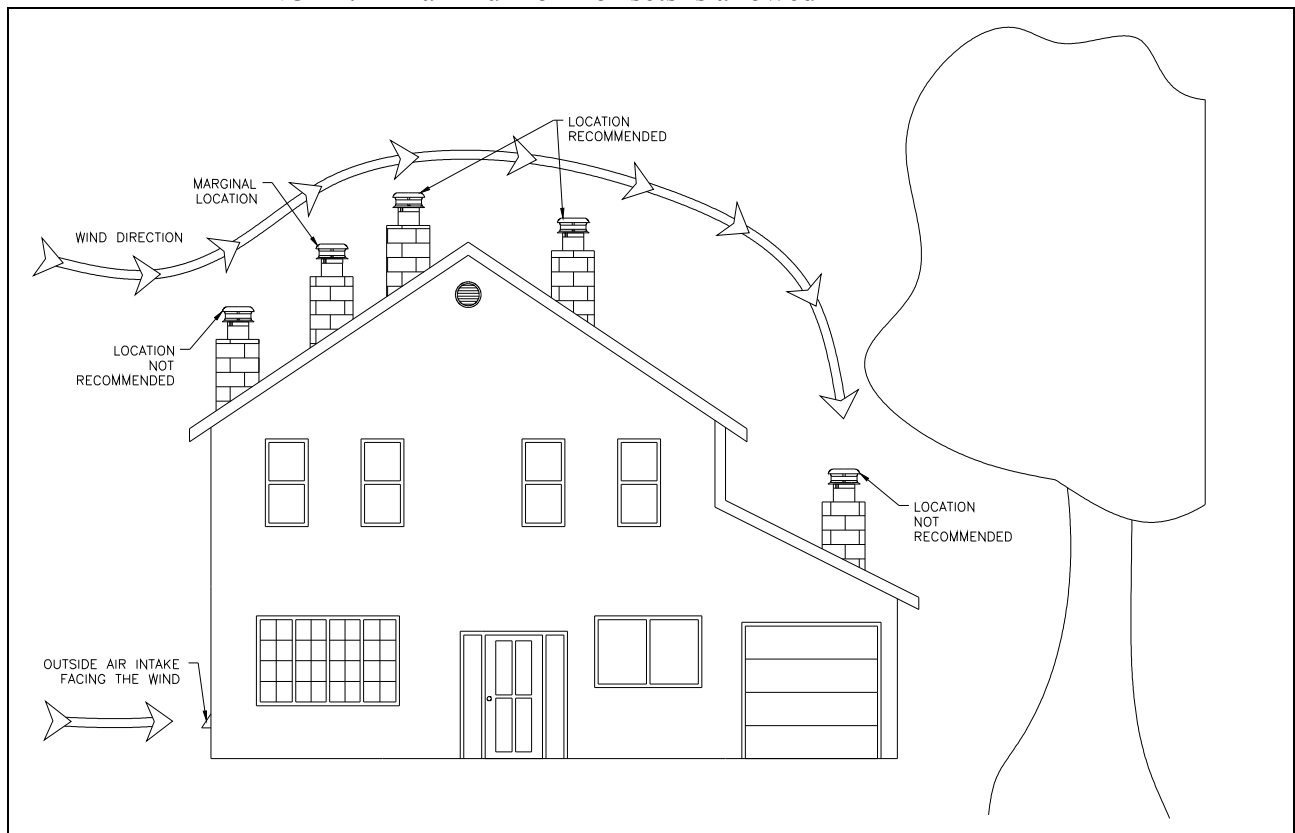

3.4.2 Hearth Extension Requirements

The LE LAVAL fireplace may be installed directly on a combustible floor; however, the combustible floor in front of the fireplace must be covered with a half inch (1/2 in.) of non-combustible support material (cement board, cement block or other) before applying the finish material (tile, marble, stone, etc.) (see figure 7 & 7.1).

WARNING: It is important not to cover the air ventilation opening below the facade trim. (free space fig. 7.1)

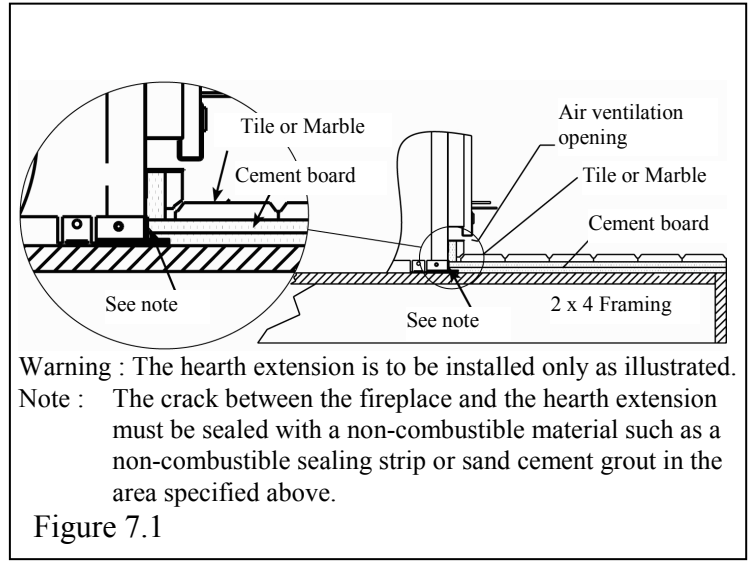
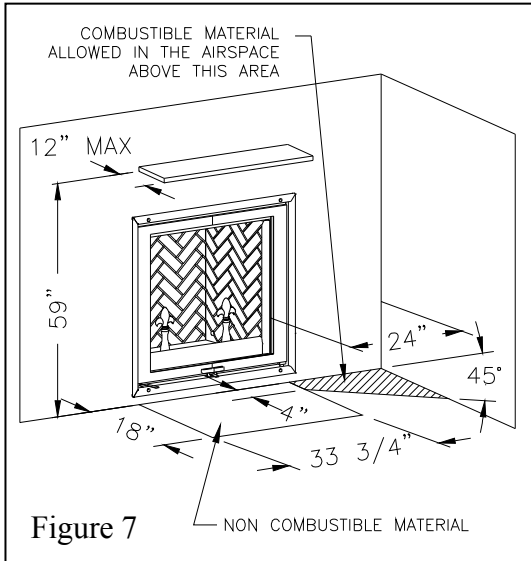

Elevated fireplace (figure 7.2)

Elevated fireplace installations require a special ‘Z’ metal safety strip (field provided), in place of the safety metal strip shown on figure 7.1. The safety strip should extend the full width of the fireplace. When more than one strip are used, they must overlap by a minimum of 1 inch.

Hearth extension of an elevated fireplace must respect the same minimal dimensions as a fireplace installed directly on the floor (figure 7).

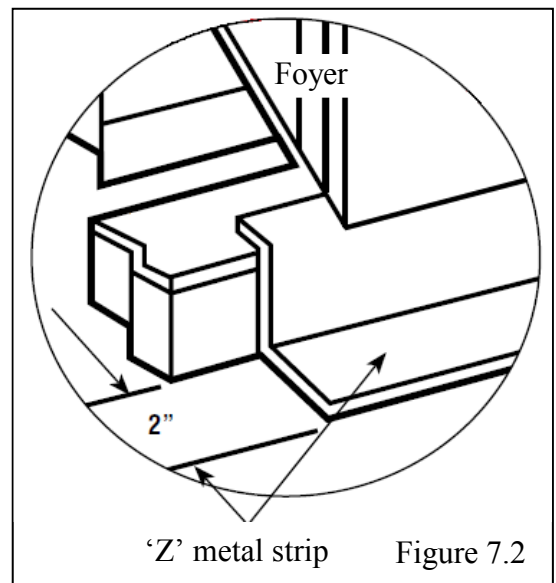

3.4.3 Framing, Facing and Mantel

The construction of the framing, facing, and mantel must be in accordance with the standards and the following illustrations (figures 8 to 12):

- A. Frame the fireplace using 2" x 3" or heavier lumber.
- B. **WARNING:** Combustible materials cannot be used in the space directly above the fireplace, except for the studs above the facade that support the facing and mantel. This area must remain empty for **a height of 7' 6" (2286 mm) measured from the base of the appliance.**
- C. Frame the fireplace with vertical studs at the sides of the fireplace running from floor to ceiling (see figure 10). If combustible facing is to be used, position the studs back, from the front edge of the fireplace the thickness of the facing material so that the facing can be installed flush with the fireplace facing. Frame headers between the vertical studs only as follows:
 - Place 2" x 3" or 2" x 4" headers, only along the upper part of the front, side and back faces. Do not put wood or any combustible material within the area above the fireplace except on the front facing.
 - Place headers only as required to support the facing and mantel.

D. **WARNING:** The fireplace must not be in contact with any insulation or loose filling material. Cover the insulation with drywall panels or any other rigid material around the fireplace.

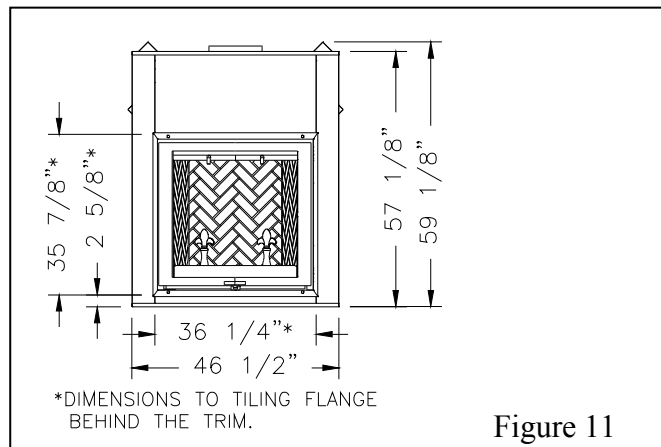
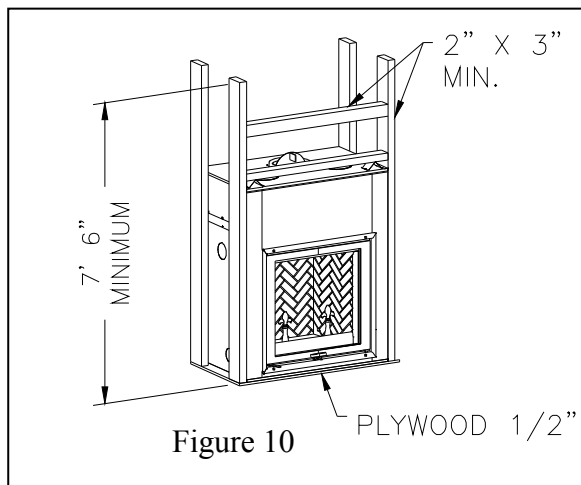
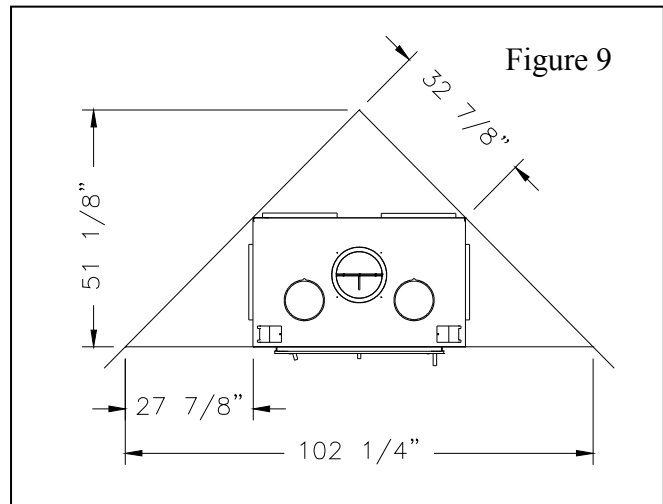
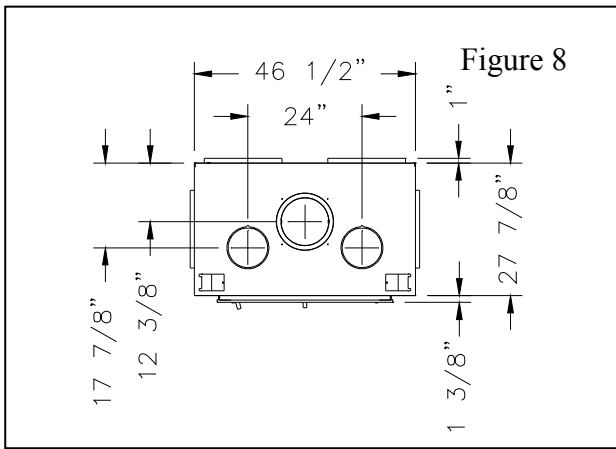

INSULATED CHASE CONSTRUCTION

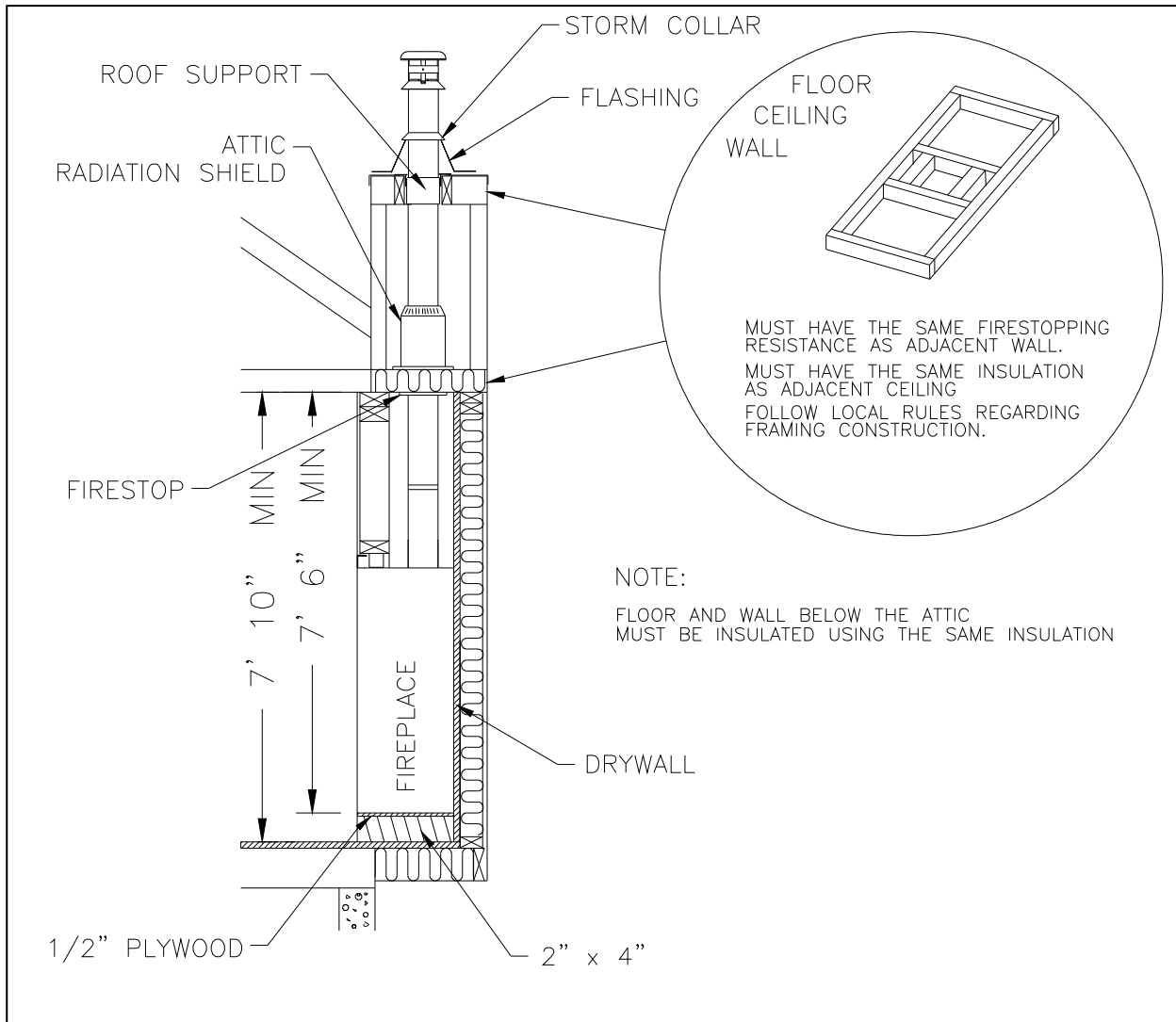
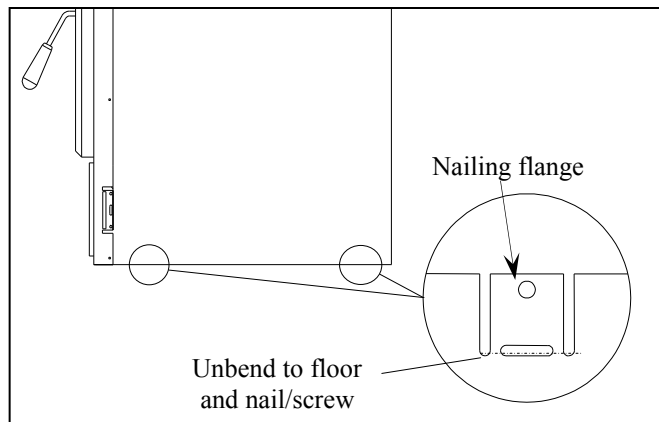

Figure 12

Nailing flange

Four nailing flanges are provided to secure the fireplace to the floor (see figure beside). Bend the nailing flanges down so each flange is flush with the floor, then using nails or screws, secure the fireplace to the floor (2 places per side). The heads of the screws or nails must be large enough to cover the holes in the nailing flanges.



Facing

Note: The facade must be removable once installed. The facade is designed to overlap any facing material installed on the front of the fireplace. If thicker material is installed, use the facade as a template and make sure it can be easily removed for servicing.

1. Combustible material must be installed flush with the fireplace. It may not project in front of and on the fireplace (i.e. the steel facade of the fireplace) (figure 15).
2. Non-combustible materials such as brick, stone or ceramic tile may project in front of and onto the fireplace facing (figure 14).

1. Fireplace
2. Front of fireplace
3. Wood frame (2" x 3" min)
4. Drywall
5. Tiles
6. Rock board or other
7. Brick

FIREPLACE FRAME SECTION
(TOP VIEW)

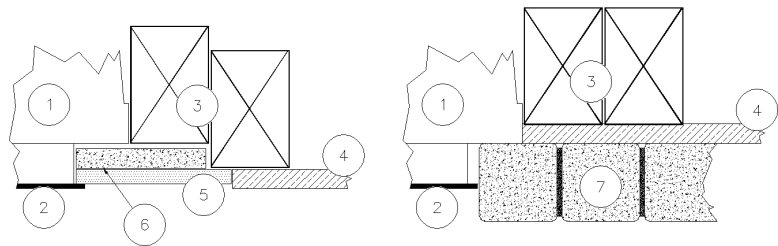

Mantel

The mantel must be installed at least 59" (1500 mm) above the base of the fireplace (figure 13).

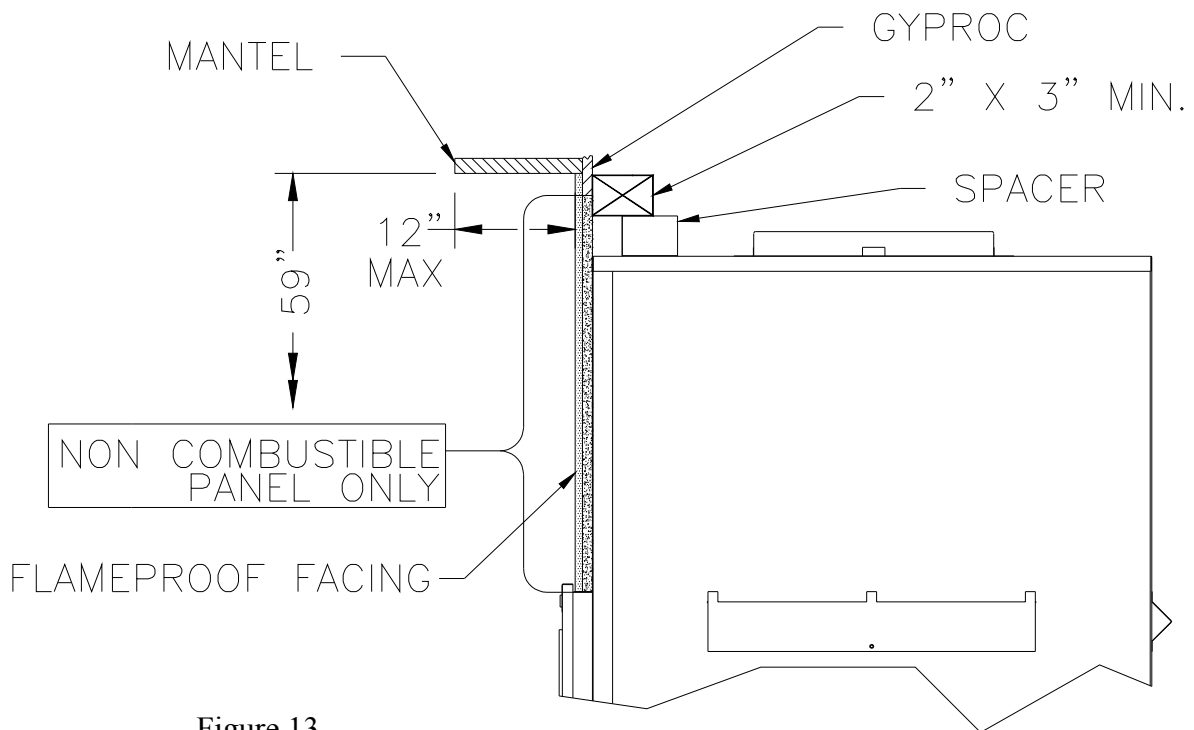
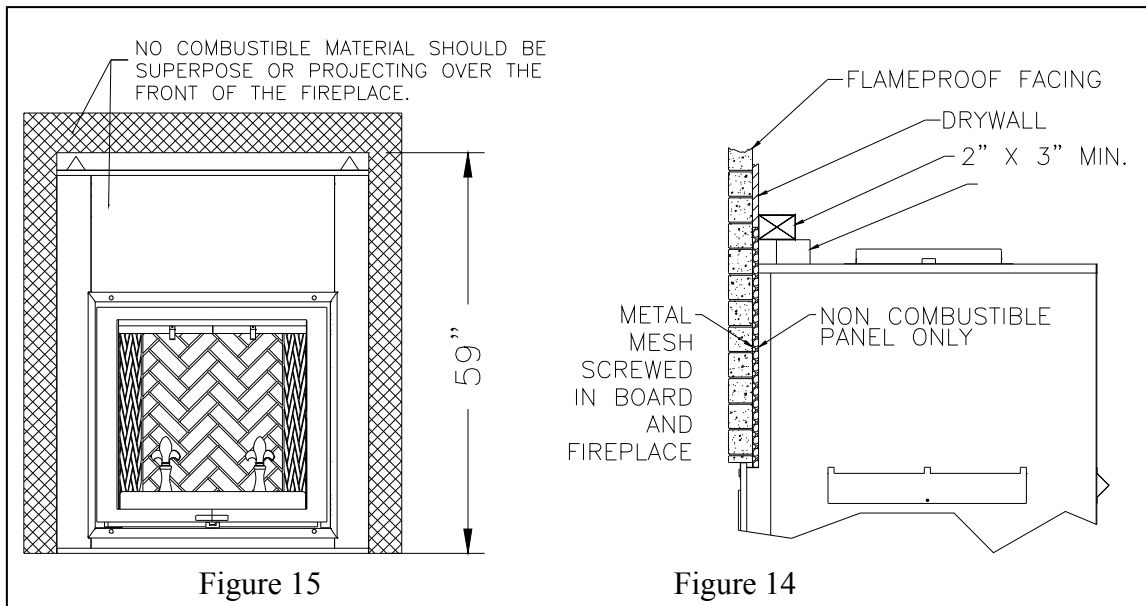

Figure 13



3.4.4 Optional Fireplace Blower (UZY5)

A heat activated blower is sold as an option. It is designed to be located in the back of the fireplace and increase the air flow around the firebox. It uses regular 120V and must be connected to the main electrical circuit by a qualified electrician. **An electrical box must be installed outside the fireplace.**

WARNING: Because of the fireplace size and obstructive air venting, we don't recommend the installation of the blower unless the gravity duct are installed on the fireplace.

If you wish to adjust the blower speed, an optional variable speed control (VRUW) can be installed in line with the wiring. Again, use a qualified electrician for installation.

To install the blower,

- 1- Remove the refractory bricks and the andiron.
- 2- Remove the metal plates covering the bottom and back of the hearth firebox.
- 3- Disconnect the main electric cable from the blowers by unplugging its two quick connectors.
- 4- Remove the knock-out in the front right side of the fireplace outer casing.
- 5- Install a metallic wire protector and slide the blower main electrical cable from the outside to the inside of the unit.
- 6- Install the two fans in the back of the fireplace through the holes in the back.
Warning: Make sure there are no contact between the fans and the door slider.
- 7- Reconnect the main cable quick connectors and stick (magnet) the heat activate switch under the right side of the firebox. **Using aluminums tape, make sure no wiring touch the firebox by taping it to the bottom of the fireplace panel.**
- 8- Install all plates, bricks and andiron.
- 9- Connect the blower plug into the electrical box located outside the fireplace

3.5 **HOT AIR DUCTING INSTALLATION (optional)**

Different hot air ducting systems can be installed with the LE LAVAL fireplace:

- Gravity kit
- Forced air kit

The gravity kit is used when the rooms are on same level or floor as the fireplace or on an upper level or floor. If the heat to be distributed is on a lower level or floor or through the central heat duct of a furnace, then the forced air kit **MUST** be used.

3.5.1 *Gravity Kit*

Double hot air outlet including:

(See figure 16)

- 2 telescopic lengths 8" I.D.
- 2 90° elbows 8" I.D.
- 2 hot air outlet kits (grill and frames)
- 2 adaptors

See components list section 5.

Only the fan available with the fireplace can be used with the gravity kit .

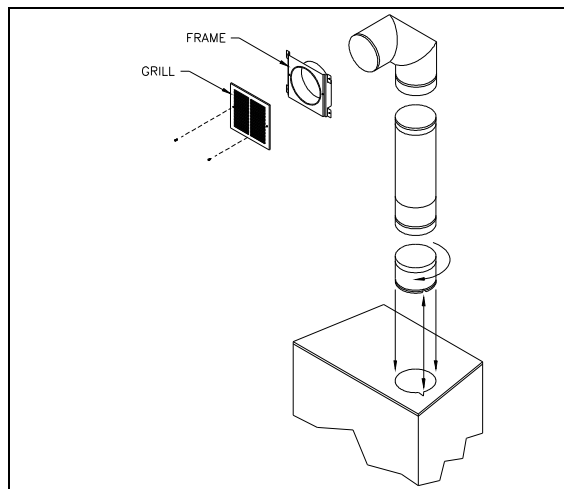

Figure 16

The safety rules for hot air ducting gravity kit installations are the following:

Minimum height*	68" (1727 mm)
Maximum length	See figure 18

* The height of the louver must be measured from the base of the LE LAVAL fireplace to the middle point of the louver.

WARNING: both pipe of the double hot air outlet must be installed. Any other installation can cause greater risk of fire and void the warranty.

When installing the double outlet system, the hot air outlets can be installed in the same room as the fireplace, or one or both of the outlets can be installed in adjacent or upper rooms. Installing the ducts at different elevations will tend to exhaust more heat out of the higher outlet (figure 18).

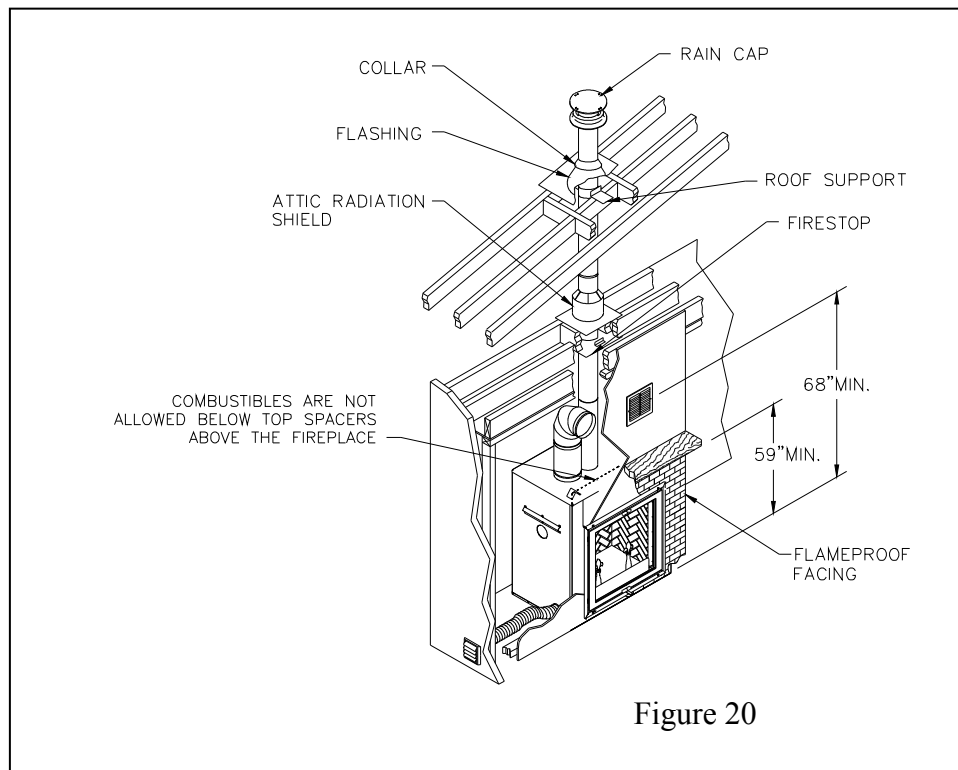
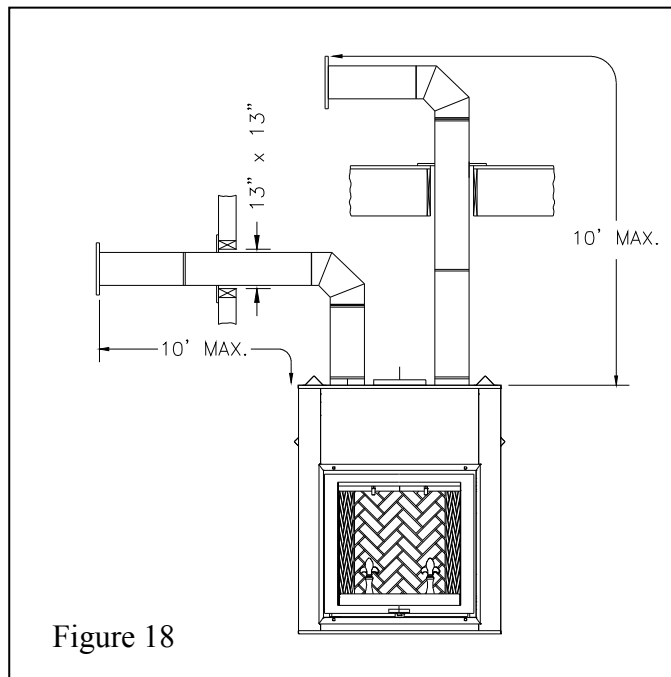

The duct system must be installed respecting the following:

1. Remove the plates closing up the 8" dia. holes on top of the fireplace. Then, cut the insulation in order to obtain two 8" dia. openings. Fix the adaptors on the fireplace openings by turning clockwise (figure 16).
2. Maintain at least a 2" (50 mm) clearance between the ducts and any combustible material; the required hole size is 13" x 13" (330 mm x 330 mm).

Exception: For the grills, the framing can be 10 ³/₄" x 10 ³/₄" (275 mm x 275 mm) to provide the clearance as required by the integral spacers on the double outlet duct system.

3. The maximum number of elbows in a run of duct is two.
4. Maintain at least 6 ¹/₂" (160 mm) clearance from the outlet grill framing to a combustible ceiling, side wall or mantel.
5. When traversing a combustible wall or floor, a firestop must be installed at the wall or floor penetration. The hole size must be 13" X 13". (330 mm x 330 mm)
6. Do not connect the hot air ducts to a central heating system. Malfunction of the heating system's fan will cause the fireplace to overheat. A furnace duct is only single wall and not double wall as is required for the LE LAVAL hot air exhaust.
7. Use only Security Chimneys International grills and components as described in this manual. Other grills or registers may be too restrictive and may overheat the fireplace or ceiling.
8. Do not use insulated flexible ducts as they will overheat.
9. Do not use tees or any other components than the ones specifically listed here.
10. All ducts must extend upwards or horizontally. Never route the ducting downwards.
11. The hot air outlet grills must be installed with the louvers pointing downwards in order to prevent overheating adjacent ceilings.

3.5.2 Central Forced Air Kit

The knock-outs provided on the back and on the sides of the LE LAVAL fireplace allow the connection of insulated flexible pipe which enables you to heat adjacent rooms up to 50 feet from the fireplace hot air outlet.

The ducting system must be installed as described below:

- A) Fix the adaptor at the back and/or the side of the fireplace by twist-locking the adaptor to the fireplace. You can use more than one outlet on the fireplace (figure 21).
- B) Attach the 5" flexible pipe, using the collars provided. Important: Make sure that the plastic wrapping around the flexible pipe will not be in contact with the fireplace.
- C) Route the flexible pipe to the chosen location. The ducting system can be installed either in an upper room or in a lower room.
- D) Attach the flexible pipe to the fan, using the collars (figure 22).
- E) Fix the back draft damper to the fan outlet.
- F) Attach a flexible pipe to the fan / flexible pipe adapter (square to round) and stretch it up to the location where the heat is required.
- G) At that point, the flexible pipe can be attached to any air distribution grill
- H) Install the *blower heating and cooling thermostat* (HCTW) in that part of the house to be heated by the hot air duct. The thermostat can be switched to a cooling thermostat and installed in the same room as the unit. This thermostat will turn on the blower when the room where the fireplace is located becomes too hot.

This option requires electricity. Make sure that the connections to the fan have been made according to the local codes and comply with their requirements (see instruction provided with the thermostat). For more information regarding central forced and ducting, consult the BISFWK-1 installation sheet provided with the kit.

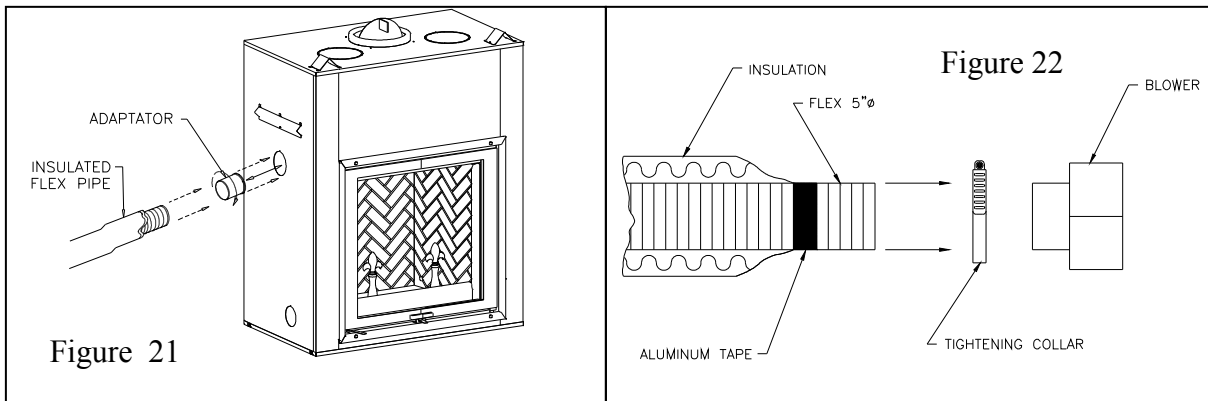

3.6 OUTSIDE AIR

It is mandatory to install an outside air connection to the LE LAVAL fireplace. The following components are required and are included with the fireplace:

- Outside air kit
- 4" adapter for fireplace connection

The outside air assembly must be installed according to the following requirements :

- A) Duct length should be kept to a minimum. The maximum length of a 4" interior diameter (100 mm) insulated flexible duct is 20 ft. (6.1 m). The duct can be extended to a maximum of 40 ft. (12 m) using a 6" interior diameter (150 mm) insulated flexible duct (See note below).
- B) The air intake register must not be installed more than 10 ft. (3050 mm) above the base of the fireplace.
- C) The fresh air must come from outside the house. The air intake must not draw air from the attic, basement or garage.
- D) The air intake should be installed where it is not likely to be blocked by snow or exposed to extreme wind and away from automobile exhaust fumes, gas meters and other vents.
- E) The duct and register may be installed above or below floor level.

Make a 4 ¼" (110 mm) hole in the outside wall of the house at the chosen location. From outside, place the outside air register in the hole (open side down) and fasten the register to the wall with screws as shown (see figure 24). Slip the pipe into the insulated sleeve. Place the insulated pipe over the register tube and over the fireplace's outside air connector (see figure 25). At each end, carefully pull back the insulation and plastic cover exposing the flexible pipe. Using the aluminium tape provided, wrap the tape around the joint between the flexible pipe and the air inlets. Carefully push the insulation and plastic cover back over the pipe. Using aluminium tape, fasten the plastic cover in place.

NOTE: We recommend not to exceed 20 feet of 4" flexible pipe. If you require a longer length we recommend that you use a 5" diameter flexible pipe for the complete run up to 30 feet and a 6" diameter pipe for a run of up to 40 feet.

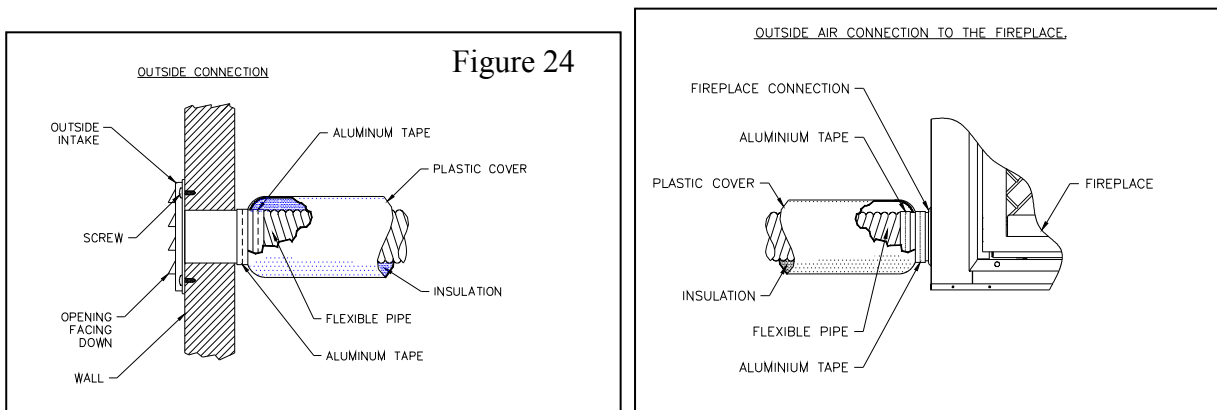

4. THE CHIMNEY

4.1 CHIMNEY INSTALLATION NOTES

1. If possible, install an interior chimney as it will provide better performance. In areas with continuous temperatures below 18°C (0°F), the use of an exterior chimney increases the likelihood of operating problems such as low draft, high rate of creosoting, and poor start-up characteristics. Exterior chimneys are also prone to down-drafting and flow reversal. Installations which are located on lower floors in the house, such as in a basement, in combination with an outside chimney, are especially prone to flow reversal.

NOTE : In areas where winter temperatures are below freezing, the air cooled chimney may produce condensation. This condensation may corrode the top of the fireplace and is not covered under warranty. For optimum performance of your fireplace, Security Chimneys International recommends the use of ASHT+ or HT6103+ chimneys.

2. The Security fireplace model LE LAVAL is listed only with Security Chimneys International Ltd 10" dia. chimney systems model Secure Temp^{ASHT+} / Nova Temp^{HT6103+} or AC.
3. A chimney venting a fireplace shall not vent any other appliance.
4. The minimum chimney height is 15 ft. (4.6 m) excluding the fireplace.
5. All chimney installations must include at least one support in order to be able to take any lateral load. The maximum chimney length that can be supported by the fireplace is 12 ft. (3.7 m) for Secure Temp^{ASHT+} / Nova Temp^{HT6103+} and 26 ft. (8m) for AC chimney. In altitude, add 18" (450 mm) to the chimney for every 2000 feet (600 m) above sea level.
6. The chimney must extend at least 3 ft. (915 mm) above its point of contact with the roof and at least 2 ft. (610 mm) higher than any wall, roof or building within 10 ft. (3m) of it (Figure 26).
7. If the chimney extends higher than 5 ft. (1500 mm) above its point of contact with the roof, it must be secured using a roof brace.
8. A rain cap must be installed on top of the chimney. Failure to install a rain cap may cause corrosion problems.
9. Cut and frame square holes in all floors, ceilings, and roof that the chimney will go through to provide a 2" (50 mm) clearance between the chimney and any combustible materials. Do not fill this 2" space with insulation or any other combustible material.
10. Portions of the chimney which may extend through accessible spaces must be enclosed to avoid contact with combustible materials or damage the chimney.

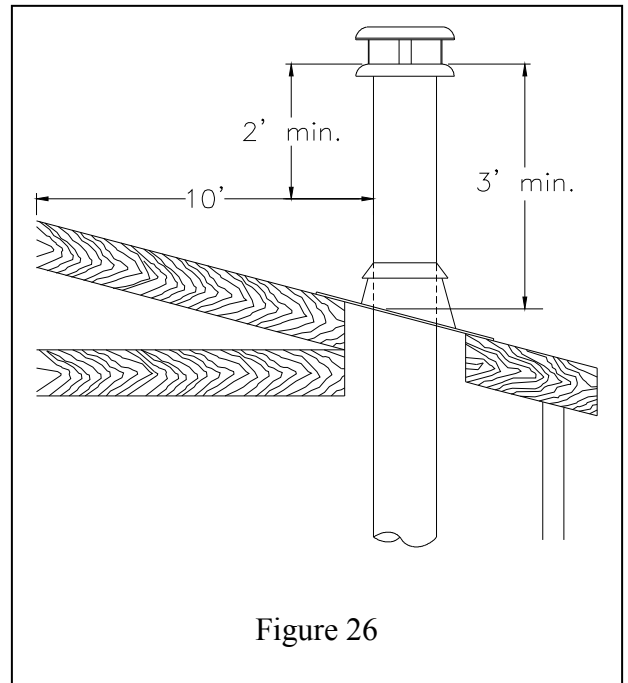

Figure 26

4.2 CHIMNEY INSTALLATION INSTRUCTIONS

1. Cut and frame the holes in the ceiling, floor and roof where the chimney will pass (see figure 27). Use a plumb bob to line up the centre of the holes. The sizes are indicated in table 1 for the floor and ceiling holes and table 2 (page 28) for the roof holes.

CHIMNEY MODEL	HOLE SIZE
Secure Temp ^{ASHT+} Nova Temp ^{HT6103+}	16 3/8 in. (416 mm)
AC :	17 in. (432 mm)

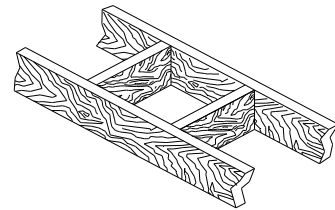

Figure 27

Table 1

From below, install a firestop in each ceiling/floor separation through which the chimney will pass. At the attic level, install an attic radiation shield from above. (figures 28 & 29).

2. For Secure Temp^{ASHT+} / Nova Temp^{HT6103+} chimneys, place the first chimney length on the fireplace. To lock it in place, turn ¼ of a turn clockwise. With the AC chimney, you must use a starter section before installing the first chimney length (figure 30). Continue installing chimney lengths making sure to lock each length in place.
3. Every time the chimney passes through a ceiling or a wall, install the appropriate firestop. When you reach the desired height, install the roof support. (Refer to instructions included with the support). For an AC chimney use an universal support AC10SU.
4. Put the roof flashing in place and seal the joint between the roof and the flashing with roofing pitch. (see figures 31 & 32). For sloping roofs, place the flashing under the upper shingles and on top of the lower shingles. Nail the flashing to the roof, using roofing nails.
5. Place the storm collar over the flashing, and tighten it with the bolt supplied. Finally, seal the joint between the storm collar and the chimney, using silicone caulking.
6. Install the chimney cap.

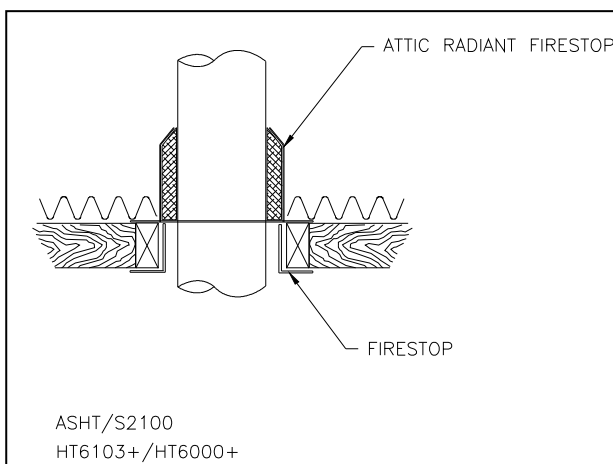

Figure 28

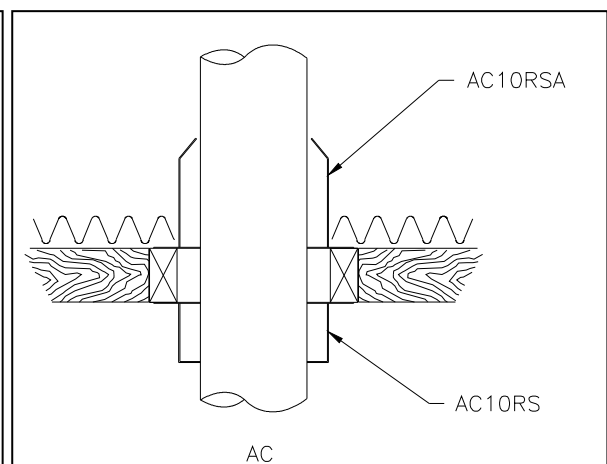

Figure 29

CHIMNEY INSTALLATION MODEL AC

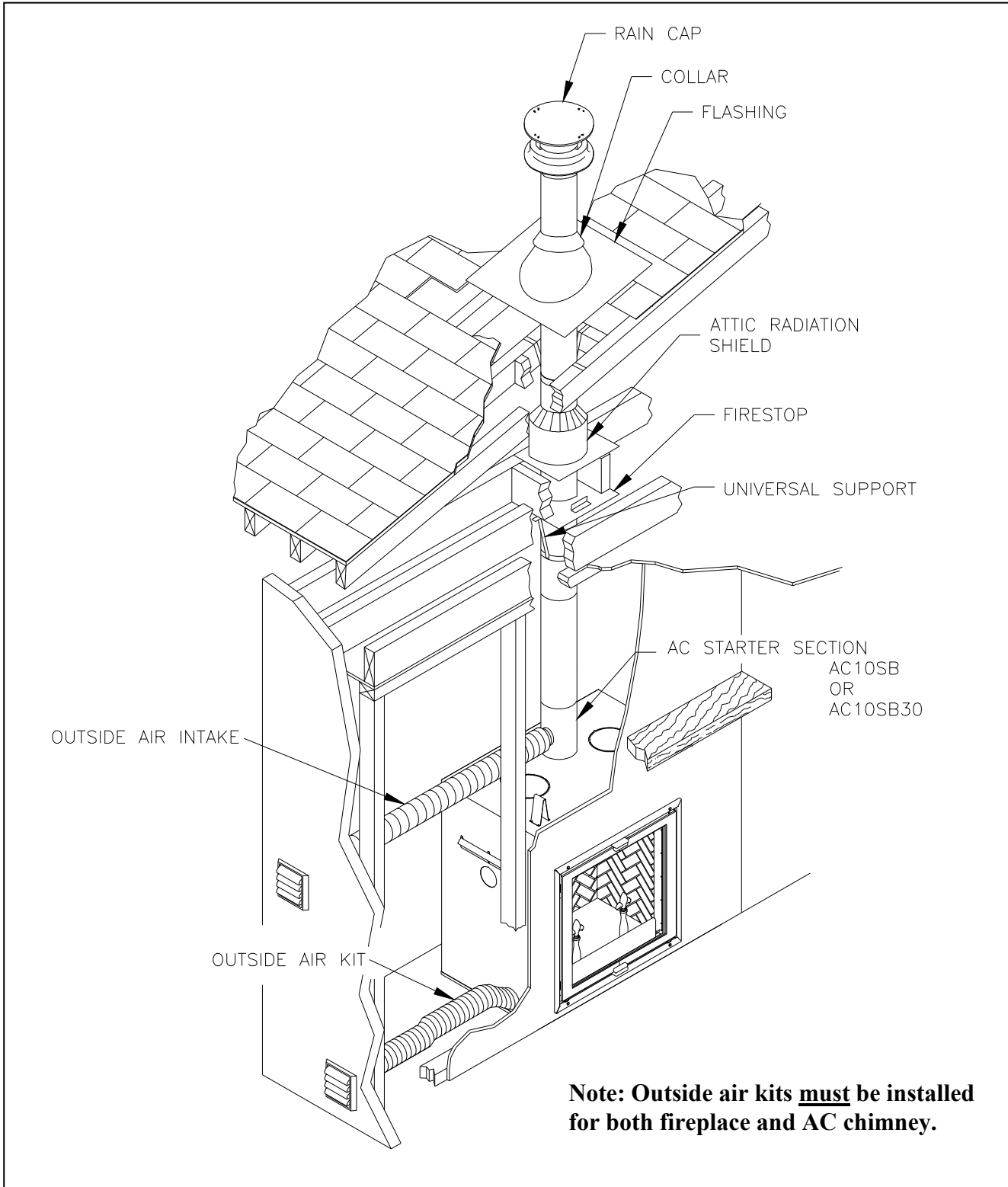

Figure 30

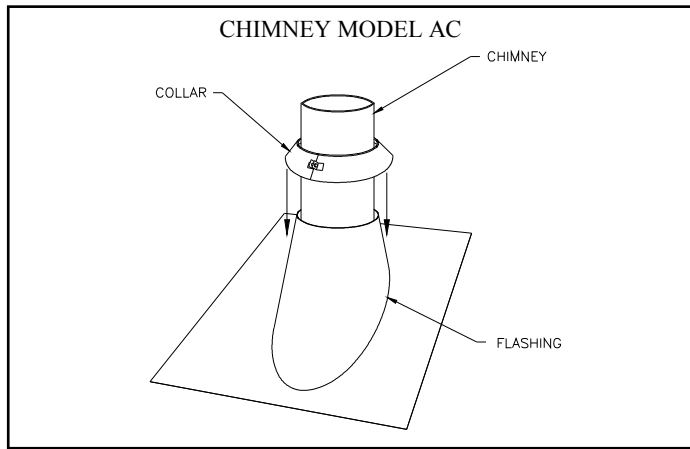

Figure 31

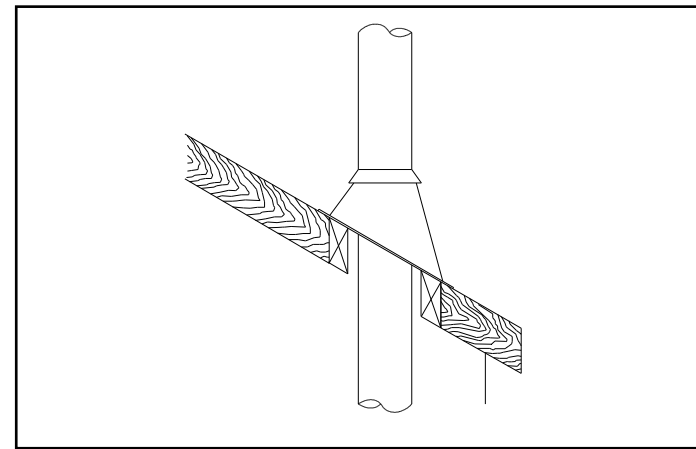

Figure 32

Table 2

ROOF DOWN SLOPE HOLE SIZE		
DEGREE OF SLOPE	Secure Temp ^{ASHT+} Nova Temp ^{HT6103+}	AC
	10"	10"
0 *	16 3/8" (416 mm)	17" (432 mm)
2/12	16 5/8" (422 mm)	17 1/4" (438 mm)
4/12	17 1/4" (439 mm)	18" (457 mm)
6/12	18 3/8" (466 mm)	19" (482 mm)
8/12	19 3/4" (500 mm)	20 1/2" (520 mm)
10/12	21 3/8" (542 mm)	22 1/8" (562 mm)
12/12	23 1/8" (588 mm)	24" (611 mm)

* CROSS SLOPE HOLE SIZE

4.3 OFFSET CHIMNEY INSTALLATION

The minimum chimney height when using elbows is:

Fireplace Model	LE LAVAL
Chimney Model	Secure Temp ^{ASHT+} / Nova Temp ^{HT6103+} / AC
Vertical Installation	4.57 m (15')
Two (2) Elbows	5.49 m (18')
Four (4) Elbows	6.10 m (20')

Table 3

NOTE: a maximum of 2 offsets is allowed.

After reaching the location requiring the elbow, proceed as follows:

Secure Temp^{ASHT+} / Nova Temp^{HT6103+} Chimneys

1. Install the first elbow; turn it in the required direction. Fasten it to the chimney with the three (3) ½" (12 mm) metal screws provided with the elbow.
2. Install the necessary chimney lengths to achieve the required offset. Lock the chimney lengths together: it is recommended to use three (3) ½" (12 mm) screws. If the offset length is made of two (2) chimney lengths or more, use an offset support halfway up the offset. If penetrating a wall, install a wall radiation shield (see figures 34 & 35).
3. Use another elbow to turn the chimney vertically. Secure the elbow, using three (3) ½" (12 mm) screws (provided with the elbow).
4. Use a plumb bob to line up the centre of the hole. Cut a hole for the chimney in the ceiling/floor. Frame this hole as described previously (refer to section 4.2).
5. From below, install a firestop (See figure 28).
6. A support (ST+ or SO+) must be used on the first 15' section (5 m.).
7. Continue with the regular installation.

AC Chimney

1. Install the first elbow. Turn it in the required direction. To lock it in place, turn 1/8 of a turn. Fasten the straps attached to the elbow to the surrounding frame, using nails or drywall screws (figure 33).
2. Install the necessary chimney lengths to achieve the required offset. Lock the chimney lengths together. If penetrating a wall, use a wall radiation shield.
3. Use another elbow to turn the chimney vertically. Lock it to the chimney. Fasten the straps attached to the elbow to the surrounding framing using nails or drywall screws.
4. Use a plumb bob to line up the centre of the hole. Cut a hole for the chimney in the ceiling. Frame this hole as described previously.
5. From below, install a firestop. (see figure 29).
6. Continue with the regular installation.

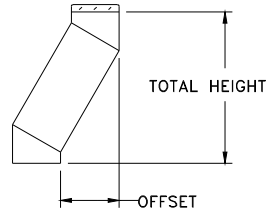

CHIMNEY	ELBOW	OFFSET & HEIGHT	ONE LENGTH BETWEEN ELBOWS						TWO LENGTH BETWEEN ELBOWS					
			8"	12"	18"	24"	36"	48"	8" & 48"	12" & 48"	18" & 48"	24" & 48"	36" & 48"	48" & 48"
ASHT+ HT6103+ 10"	15°	OFFSET	3" (76 mm)	4 1/4" (108 mm)	5 3/4" (146 mm)	7 1/4" (184 mm)	10 1/4" (260 mm)	13 1/4" (337 mm)	15 1/4" (387 mm)	16 1/4" (413 mm)	17 3/4" (451 mm)	19 1/4" (489 mm)	22 1/2" (572 mm)	25 1/2" (648 mm)
		HEIGHT	16 1/2" (419 mm)	20 1/4" (514 mm)	26 1/4" (749 mm)	32" (813 mm)	43 1/2" (1105 mm)	55 1/2" (1410 mm)	62" (1575 mm)	65 3/4" (1670 mm)	71 1/2" (1816 mm)	77 1/4" (1962 mm)	89" (2261 mm)	100 1/2" (2552 mm)
	30°	OFFSET	7 1/2" (191 mm)	9 1/2" (241 mm)	12 1/2" (318 mm)	15 1/2" (394 mm)	21 1/2" (546 mm)	27 1/2" (699 mm)	31" (787 mm)	33" (838 mm)	36" (914 mm)	39" (991 mm)	45" (1143 mm)	51" (1295 mm)
		HEIGHT	20 3/4" (527 mm)	24 1/4" (641 mm)	29 1/2" (749 mm)	34 3/4" (883 mm)	45" (1143 mm)	56 1/4" (1429 mm)	62 1/2" (1588 mm)	65 3/4" (1670 mm)	71 1/4" (1810 mm)	76 1/2" (1943 mm)	86 3/4" (2203 mm)	98" (2489 mm)
	45° CANADA ONLY	OFFSET	10 1/2" (267 mm)	13 1/2" (343 mm)	17 3/4" (451 mm)	22" (559 mm)	30 1/2" (775 mm)	39" (991 mm)	44" (1118 mm)	46 3/4" (1187 mm)	51" (1295 mm)	55 1/4" (1403 mm)	63 3/4" (1619 mm)	72 1/4" (1835 mm)
		HEIGHT	18 1/2" (470 mm)	21 1/4" (540 mm)	25 1/2" (648 mm)	29 3/4" (756 mm)	38 1/4" (972 mm)	46 3/4" (1187 mm)	51 3/4" (1314 mm)	54 3/4" (1391 mm)	59" (1499 mm)	63 1/4" (1607 mm)	71 3/4" (1822 mm)	80 1/4" (2038 mm)
CHIMNEY	ELBOW	DEVIATION & HAUTEUR	ONE LENGTH BETWEEN ELBOWS						TWO LENGTH BETWEEN ELBOWS					
			---	12"	18"	36"	48"	---	---	12" & 48"	18" & 48"	36" & 48"	48" & 48"	---
AC 10"	15°	OFFSET	----	4 1/4" (108 mm)	5 3/4" (146 mm)	7 1/4" (184 mm)	10 1/4" (260 mm)	----	----	16 1/4" (413 mm)	17 3/4" (451 mm)	22 1/2" (572 mm)	25 1/2" (648 mm)	----
		HEIGHT	----	20 1/4" (514 mm)	26 1/4" (667 mm)	32" (813 mm)	43 1/2" (1105 mm)	----	----	65 3/4" (1670 mm)	71 1/2" (1816 mm)	89" (2261 mm)	100 1/2" (2553 mm)	----
	30°	OFFSET	----	9 1/2" (241 mm)	12 1/2" (318 mm)	15 1/2" (594 mm)	21 1/2" (546 mm)	----	----	33" (838 mm)	36" (914 mm)	45" (1143 mm)	51" (1295 mm)	----
		HEIGHT	----	24 1/4" (641 mm)	29 1/2" (749 mm)	34 3/4" (883 mm)	45" (1143 mm)	----	----	65" (1651 mm)	70 1/4" (1784 mm)	85 3/4" (2178 mm)	96" (2438 mm)	----

Table 4

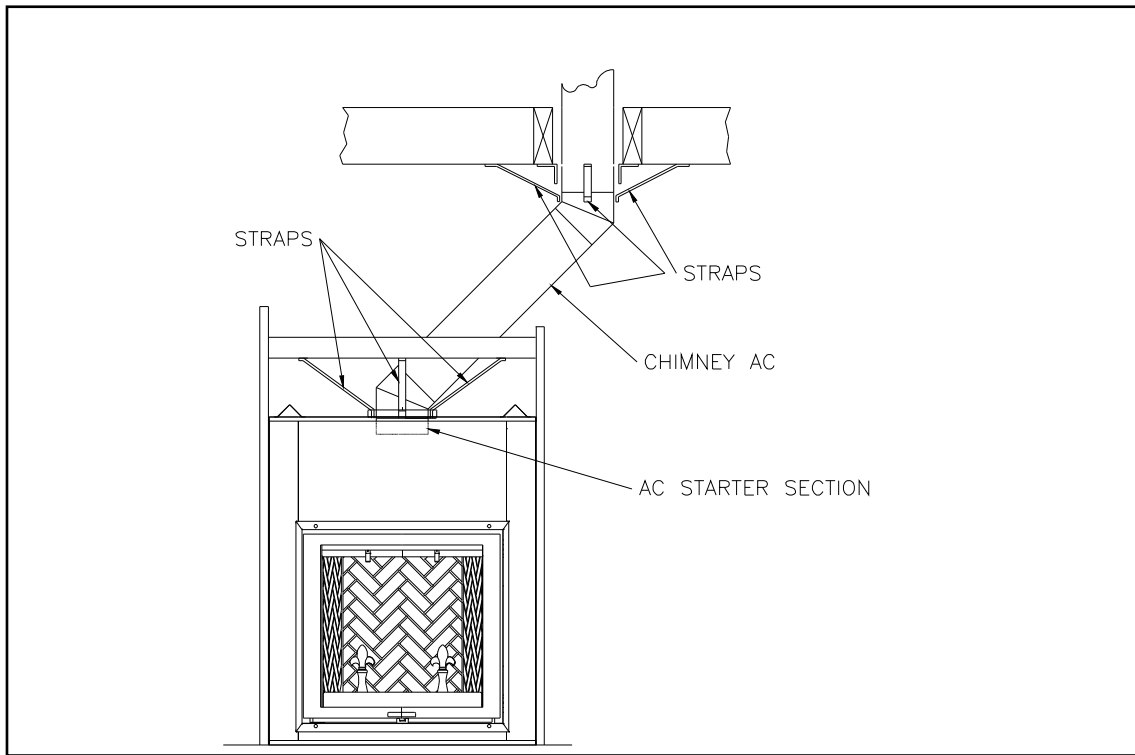

Figure 33

NOTE: IN COLD AREAS IT IS RECOMMENDED TO PROTECT THE CHIMNEY IN A INSULATED CHASE.

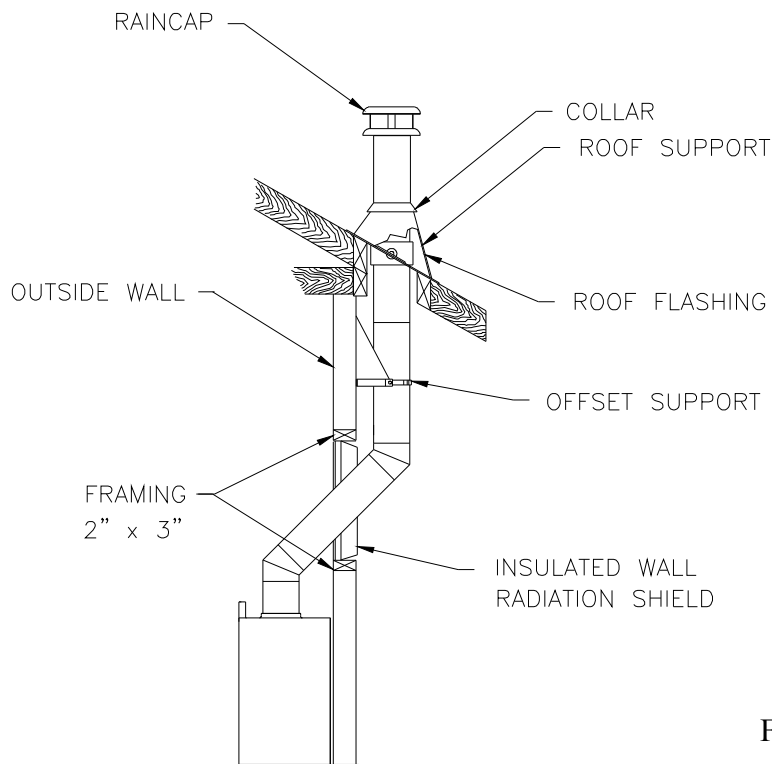

Figure 34

IF THE CEILING IS 9 FT OR LESS THIS INSTALLATION CAN ONLY BE ACHIEVED USING 45° ELBOWS. SINCE ONLY 30° ELBOWS ARE ALLOWED. IN THE U.S. THE OFFSET MUST BE DONE ABOVE THE CEILING.

4.4 ANGLED WALL RADIATION SHIELD (RSMI30, RSMI45, AC10RSMI30)

When traversing a combustible wall with the chimney at a 30° or 45° angle, an angled firestop or wall radiation shield must be installed. Only one is required.

Note: 45° angle for Canada only

In cold climate locations, we recommend that you use the insulated wall radiation shield since it will maintain the home's thermal barrier.

RSMI30, RSMI45, AC10RSMI30		
CHIMNEY (7" dia.)	ANGLE	HOLE DIMENSION
Secure Temp ^{ASHT+} Nova Temp ^{HT6103+}	30°	17 9/16" x 45 3/4" (446 mm x 1162 mm)
Secure Temp ^{ASHT+} Nova Temp ^{HT6103+}	45° Canada only	17 1/2" x 30" (444 mm x 762 mm)
AC	30°	17" x 42 1/2" (432 mm x 1080 mm)

Tableau 5

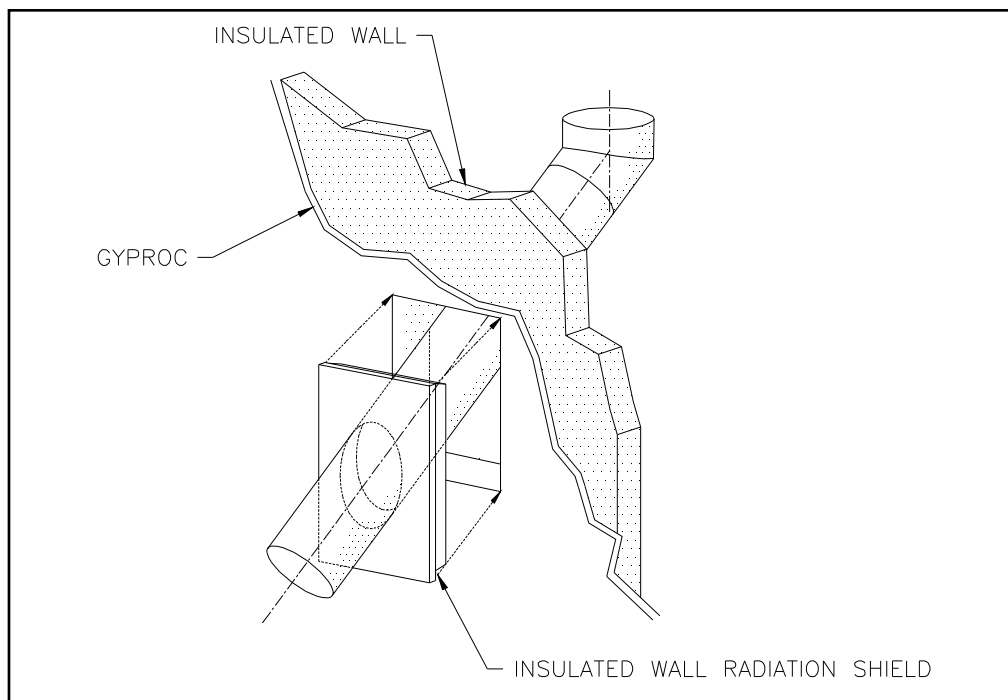

Figure 35

4.5 CHIMNEY SUPPORT INSTALLATION

UNIVERSAL ROOF SUPPORT

This support has three possible uses:

1. For Secure Temp^{ASHT+} / Nova Temp^{HT6103+}, it must be used on a roof to support the chimney.
2. It may be used on a floor, ceiling or roof above an offset to support the chimney above the offset.
3. It may be used on a floor, ceiling or roof as a supplementary support when the chimney height exceeds 12 ft. (3.7 m.).

Table 6 gives maximum height of supported chimney.

NOTE: For the AC chimney, a support section (AC10SL) must be used every 20 ft. (6m) or an universal support every 15 ft. (4.5m) instead of the universal roof support (ST).

For roof support installation, refer to the instructions provided with the support.

UNIVERSAL OFFSET SUPPORT

This support is used to support the chimney above an offset. When the chimney offset is used to traverse a wall this support may be used on the wall to support the chimney. The maximum heights are given in Table 6. For offset support installation, refer to the instructions provided with the support.

CHIMNEY	MAXIMUM HEIGHT SUPPORTED	
	OFFSET SUPPORT	ROOF SUPPORT
10" diameter		
Secure Temp ^{ASHT+} Nova Temp ^{HT6103+}	14 ft (4.3 m.)	20 ft (6.1 m.)
AC	30 ft (9.15 m.)	40 ft (12.16 m.)

Table 6

4.6 CHIMNEY CHASE AND MULTIPLE TERMINATIONS

For the purpose of this manual, a chimney chase is considered a part of the chimney system rather than part of a building. The termination must be placed a minimum of 18" (460 mm) above the chase.

For installations where more than one chimney is located in the same chase or within the same area, we suggest that their terminations be separated by at least 16" (410 mm) horizontally, and 18" (460 mm) vertically. This separation is to prevent smoke migrating from one chimney to another (see figure 36).

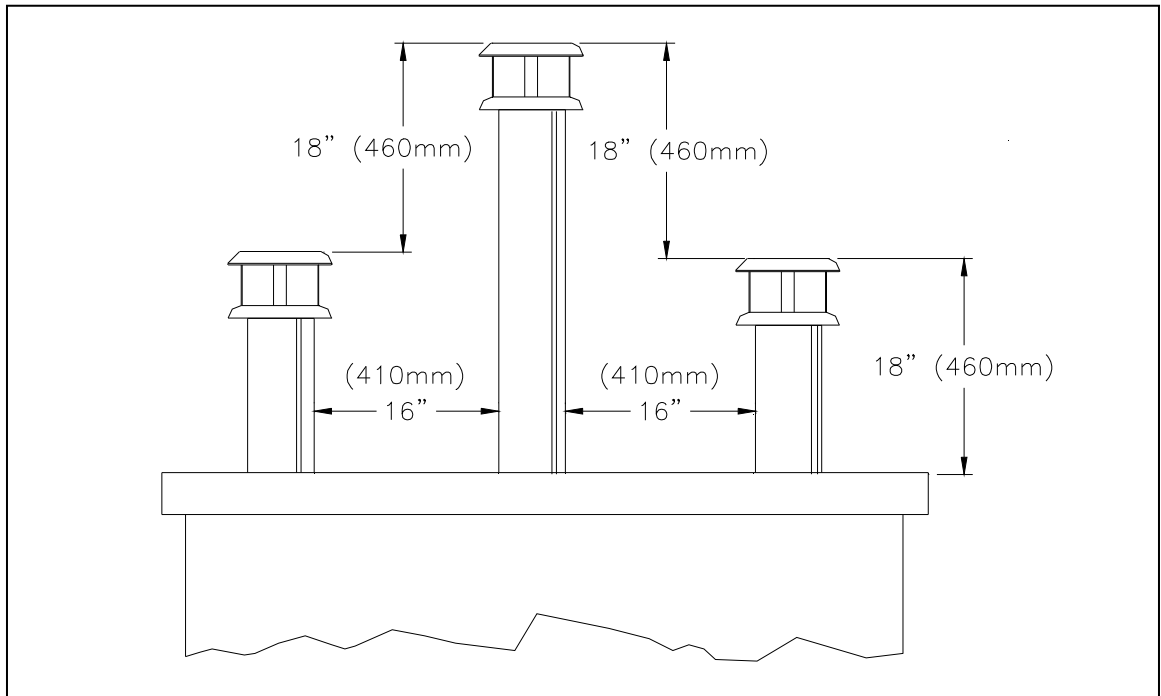

Figure 36

5. PARTS AND COMPONENTS LIST

AC Chimney

<u>Description</u>	<u>Part No.</u>	<u>Catalog No.</u>
Lengths	10" dia.	10" dia
12" length	AC10L12	H3765
18" length	AC10L18	H3766
36" length	AC10L36	H3767
48" length	AC10L48	H3768
15° elbow	AC10E15	H3760
30° elbow	AC10E30	H3761
Starter section	AC10SB	H3776
Offset starter section 30 deg.	AC10SB30	H3777
Rain cap	AC10CPR	H3759
Spark arrester screen	PE+	H0479
Supports		
Support section	AC10SL	H3778
Universal support	AC10SU	H3265
Firestop		
Firestop	AC10BF	H3758
Radiation shield	AC10RS	H3769
Attic radiation shield	ACBI7RSA	H3270
Telescopic attic radiation shield	AC10RST	H3775
Insulated wall radiation shield 30°	AC10RSMI30	H3272
Insulated wall radiation shield 45°	AC10RSMI45	H3774
Outside air kit (chimney) (flex, insulation, outside register and coupling)	ACZI	H1967
Outside air coupler for air kit	UACZI	H3274
Flat roof flashing	ACBI7FR	H3275
Adjustable roof flashings		
1/12 - 7/12 (5° - 30°)	ACBI7FAR	H3276
8/12 - 12/12 (30° - 45°)	ACBI7FBR	H3277
Storm collar	AC10FC	H3278

Fireplace components :

Description:

Outside air kit

UZI outside air kit fireplace adaptor

Part number:

UZI

UZIAD

6. OPTIONS

Gravity kit:

Complete double ducting system including: 2 elbows 90°, 2 telescopic lengths, 2 grill supports and 2 black grills

Part No.:

7B30ZK-1

Black grill with support

7B30ZO

Brass grill for 7B30ZK-1

7B30ZGB

Elbow 90°, 8" dia.

7B26ZE90

Elbow 45°, 8" dia.

7B26ZE45

Telescopic length, 8" dia.

7B26ZLA

Adjustable length, 8" dia. (2" - 5")

7B26ZL2A

Radiation shield

7B26ZR

Central forced air kit:

Central forced air kit including: blower (BISZY), flex adaptor (BISAF), 2 clamps, variable speed control (VRUW), thermo-disk (VTU), fan to flexible pipe adaptor (BISAVF), back draft damper (BISBD), aluminium tape

BISFWK-1

Fireplace to Flex adaptor and 2 clamps

BISAF

Flexible pipe 5" I.D. x 15 ft. Long

5FLEX15

Flexible pipe 5" I.D. x 30 ft. Long

5FLEX25

Blower 250 CFM for central forced air kit

BISZY

Blower variable speed control with decorative wall plate for (BISZY)

VRUW

Thermo-disk, on/off blower control for (BISZY)

VTU

Fan to flexible pipe adaptor

BISAVF

Heating and cooling thermostat

HCTW

Backdraft damper

BISBD

Fireplace blower:

Two fan kit with thermostatic control

UZY5

7. APPENDIX

SPECIFICATIONS

Weight w/ crate	675 lbs
Weight w/out crate and refractory bricks	500 lbs
Height	59 in.
Width	48 1/2 in.
Depth	29 in.
Chimney weight ASHT+ (10" dia.) :	8 1/2 lb/ft.

CLEARANCE TO COMBUSTIBLES

The following clearances meet the minimum requirements for a safe installation

Side wall (fireplace front):	24" (457 mm) measured from the fireplace door
Ceiling:	7'6" (2286 mm) measured from the base of the fireplace
Fireplace enclosure:	Bottom: 0" Side: 0" to spacers Back: 0" to spacers Top: Do not fill the space above the fireplace with any material (Except the wood framing. See figure 10)
Chimney:	2" (50 mm)
Mantel:	59" (1422 mm) measured from the base of the fireplace

REPLACEMENT PARTS

Front edge refractory brick	PR-SR2693
Back refractory brick	PR-SR2689
Right side refractory brick	PR-SR2690
Left side refractory brick	PR-SR2691
Bottom refractory brick	PR-SR2692
Wooden door handle	PR-SR2722
Ceramic glass (1)	PR-SR2677
Andiron (2)	PR-SR2708
Black metallic paint "Forrest Paint" can (SBMB6309)	70K99
Door gasket:	PR-SR1823N
Right door assembly	PR-SR2678
Left door assembly	PR-SR2679
Finishing facade	PR-SR2701
Door lock tab	PR-SR2715
Bearing	PR-SR2674
Chimney damper control handle and rod	PR-SR2762
Chimney damper plate and pivot rod	PR-SR2665
Fire screen	PR-SR2723
Fire screen support rod	PR-SR2779
Left slider assembly	PR-SR2680G
Right slider assembly	PR-SR2680D
Slider stopping plate	PR-SR2714
Right hinge	PR-SR1800DLV
Left hinge	PR-SR1800GLV
Fireplace top panel	PR-SR2661
Fireplace left side panel	PR-SR2659
Fireplace right side panel	PR-SR2660
Fireplace back panel	PR-SR2658