

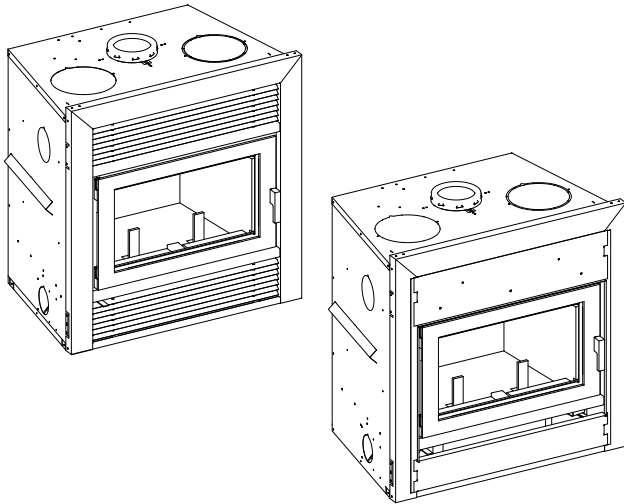



BISTM Ultima CF



	⚠ WARNINGS
	<ul style="list-style-type: none"> • Hot! Do not touch! The glass and surfaces of this appliance will be hot during operation and will retain heat for a while after shutting off the appliance. Severe burn may result. • Carefully supervise children in the same room as appliance.
<ul style="list-style-type: none"> • If small children are present in the home, it is recommended that this appliance be used with a fire screen kit. 	

 NATIONAL FIREPLACE INSTITUTE NFI CERTIFIED www.nficertified.org	<p>We suggest that our woodburning hearth products be installed and serviced by professionals who are certified in the U.S. by the National Fireplace Institute® (NFI) as NFI Woodburning Specialists or who are certified in Canada by Wood Energy Technical Training (WETT).</p> 
--	--

Installation and Operating Instructions

This installation manual will help you obtain a safe, efficient, dependable installation for your fireplace and chimney system. Please read and understand these installation instructions before beginning your installation.

CAUTION: Do not attempt to modify or alter the construction of the fireplace or its components. Any modification or alteration of construction may void the warranty, listings and approvals of this system. In that case, Security Chimneys International Ltd will not be responsible for damages. Install the fireplace only as described in these instructions.

SAVE THESE INSTRUCTIONS
FOR FUTURE REFERENCE

THIS UNIT REQUIRES THE INSTALLATION OF A FINISHING KIT. SEE SECTION 3.1.1 FOR DETAILS

This fireplace is also certified for use in mobile or manufactured homes



Listed to standards:
ULC-S610 UL-127
Report # 3011202

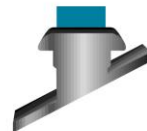

**SECURITY CHIMNEYS
INTERNATIONAL**

2125 Monterey St., Laval, Quebec, Canada, H7L 3T6

TABLE OF CONTENTS

	Page
1. SAFETY RULES and Specifications for Mobile or Manufactured Home Installation...	1
2. CERTIFICATION LABEL	2
3. THE FIREPLACE	3
3.1 INTRODUCTION	3
3.1.1 Parts Required	
3.1.2 Additional Equipment (optional)	
3.2 OPERATING THE BIS ULTIMA™ CF	4
3.2.1 Fuel	
3.2.2 First Fires	
3.2.3 Building a Fire	
3.2.4 Primary Air and Air Boost Controls	
3.2.5 Accelerated Combustion	
3.2.6 Medium Combustion	
3.2.7 Slow Combustion	
3.2.8 Refuelling For Best Performance	
3.2.9 Smoking – Causes and Troubleshooting	
3.3 MAINTAINING YOUR BIS ULTIMA CF	8
3.3.1 Creosote	
3.3.2 Chimney Maintenance	
3.3.3 Top Baffle Removal Prior to Cleaning The Chimney	
3.3.4 Dealing with a Chimney Fire	
3.3.5 Finish Door Casing Care	
3.3.6 Ashes	
3.3.7 Refractory Installation	
3.3.8 Door Installation	
3.3.9 Door Adjustment	
3.3.10 Glass Care – Replacement	
3.3.11 Glass Care – Cleaning	
3.3.12 Gasket Replacement	
3.4 FIREPLACE INSTALLATION	12
3.4.1 Locating the BIS Ultima™ CF	
3.4.2 Finishing kit installation	
3.4.3 Hearth Extension Requirements	
3.4.4 Framing, Facing and Mantel	
3.5 HOT AIR DUCTING INSTALLATION	17
3.5.1 Gravity Kit	
3.5.2 Central Forced Air Kit	
3.6 OUTSIDE AIR KIT	21
3.6.1 Outside Air Kit Installation	
4. THE CHIMNEY	22
4.1 CHIMNEY INSTALLATION NOTES	22
4.2 CHIMNEY INSTALLATION INSTRUCTIONS	23
4.3 OFFSET CHIMNEY INSTALLATION	26
4.4 ANGLED WALL RADIATION SHIELD	29
4.5 CHIMNEY SUPPORTS INSTALLATION	30
4.6 MULTIPLE TERMINATIONS	30
4.7 CHIMNEY ADAPTOR (S-2100+ / HT6000+)	31
4.8 INSTALLATION INSTRUCTIONS FOR MASONRY APPLICATION	32
5. PARTS AND COMPONENTS LIST	33
6. OPTIONS	34
7. APPENDIX (Specifications, Clearances, Replacement Parts)	34

1. SAFETY RULES FOR OPERATING YOUR FIREPLACE MODEL BIS ULTIMA™ CF

- Use only a Security Fireplace glass door, specifically designed for the model BIS Ultima™ CF fireplace.
- When cleaning the fireplace, the ashes should be placed in a metal container with a tight fitting lid. The closed container of ashes should be placed on a non-combustible floor or on the ground outside the house, pending final disposal. If the ashes are disposed of by burial in soil or otherwise locally dispersed, they should be retained in the closed container until all cinders have thoroughly cooled.
- **When installed in a mobile or manufactured home:**
 - Mobile or manufactured home installations must be installed in accordance with the requirements of the Department of Housing and Urban Development (HUD) “Mobile Home Construction and Safety standards” for US or Canada Mortgage and Housing Corporation (CMHC) for Canada.
 - The fireplace must be fastened to the floor by unfolding and screwing the small tabs on both sides at the bottom of the fireplace.
 - It is necessary to have access openings, for inspection purpose only, into built-in enclosures surrounding the fireplace installation. Such openings to require a household tool for access.
 - The vapour barrier of the mobile home shall be as close as possible of the location where the chimney assembly penetrates the ceiling and roof structure with no interference to the required clearance to combustible material.
 - When the mobile or manufactured home has a flat roof, the Attic Radiation Shield must be installed from below going through the roof (See figures 26a & 27a).
 - Warning: Do not install in a sleeping room.

Warning: The fireplace must be operated with the doors fully opened or fully closed. If the doors are left partly opened, smoke may be drawn into the room. If the unit is operated with the doors fully opened, the optional firescreen must be used.



Caution: Never use gasoline, kerosene, charcoal lighter fluid or similar liquids to start or rekindle a fire in this fireplace. Keep all such liquids well away from the fireplace at all times.

Caution: Keep combustible materials at least 48 inches away from the front of the fireplace opening.

Caution: Never leave children unattended when there is a fire burning in the fireplace.

WARNING: THIS FIREPLACE HAS NOT BEEN TESTED WITH AN UNVENTED OR VENTED GAS LOG SET. TO REDUCE RISK OF FIRE OR INJURY, DO NOT INSTALL AN UNVENTED GAS LOG SET INTO THIS FIREPLACE.

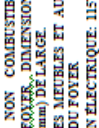
2. CERTIFICATION LABEL

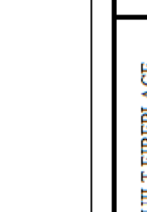
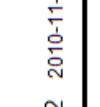
 <p>TESTED TO ULC S610 / UL 127 TESTÉ SELON (October / Octobre 2001)</p> <p><u>SUITABLE FOR MOBILE OR MANUFACTURED HOME</u></p> <p><u>CLEARANCES TO COMBUSTIBLES:</u></p> <p><u>SIDE WALL:</u> 24" (610 mm) (FROM DOOR EDGE)</p> <p><u>MANTLE:</u> 45" (1372 mm) (ABOVE FIREPLACE'S BASE)</p> <p><u>BACK WALL AND FIREPLACE SIDE:</u> MUR ARRIÈRE ET CÔTÉ DU FOYER : 0" (0 mm) (FROM SPACERS)</p> <p><u>ABOVE THE FIREPLACE:</u> 6'8" (2032 mm) (FROM THE BASE OF THE FIREPLACE) (À PARTIR DE LA BASE DU FOYER)</p> <p><u>CHIMNEY:</u> 2" (51 mm)</p>	<p>LISTED FACTORY BUILT FIREPLACE FOYER PRÉFABRIQUÉ HOMOLOGUÉ</p> <p>MODEL / MODÈLE: BIS ULTIMA CF</p> <p>ULTIMA CF -</p> <p><u>CONVIENT AUX MAISONS MOBILES</u></p> <p><u>DÉGAGEMENTS AUX COMBUSTIBLES:</u></p> <p><u>MUR LATÉRAL:</u> 24" (610 mm) (DE L'OUVERTURE DE LA PORTE)</p> <p><u>LINTEAU:</u> 45" (1372 mm) (AU-DESSUS DE LA BASE DU FOYER)</p>	<p>FUEL: WOOD ONLY</p> <p>• NON COMBUSTIBLE HEARTH EXTENSION MUST BE INSTALLED AT FRONT OF UNIT EXTENDING 18 in. (457 mm) AT FRONT AND 36 in. (914 mm) WIDE MINIMUM.</p> <p>• THIS FIREPLACE HAS NOT BEEN TESTED WITH UNVENTED GAS LOG SET. TO REDUCE RISK OF FIRE OR INJURY DO NOT INSTALL AN UNVENTED GAS LOG SET INTO THE FIREPLACE.</p> <p>• ELECTRICAL RATING: 115 V, 60 Hz.</p> <p>• USE ONLY WITH 6 in. DIAMETER CHIMNEY, CERTIFIED MODEL ASHT-5-1106*, HT6000*, HT6105* OR AC.</p> <p>• CAN BE CONNECTED TO A MASONRY CHIMNEY AS DESCRIBED IN THE INSTALLATION INSTRUCTIONS.</p> <p>• COMPONENTS USED WITH THE FIREPLACE MUST BE LISTED. SEE LIST IN THE INSTALLATION INSTRUCTIONS.</p> <p>• REPLACE GLASS WITH CERAMIC GLASS 5 mm THICK.</p> <p>• FOR SAFE OPERATION INSTALL IN ACCORDANCE WITH THE MANUFACTURER'S INSTRUCTIONS.</p> <p>• CAUTION: COMBUSTION AIR OPENING MUST NOT BE OBSTRUCTED.</p> <p>• DO NOT OVERFIRE THE FIREPLACE</p> <p>• OPERATE THE FIREPLACE WITH DOOR FULLY OPEN OR FULLY CLOSED ONLY.</p> <p>CONTACT YOUR LOCAL BUILDING OR FIRE OFFICIALS ABOUT RESTRICTIONS AND INSTALLATION INSPECTIONS IN YOUR AREA.</p>	<p>COMBUSTIBLE: BOIS SEULEMENT</p> <p>• UN TABLIER NON COMBUSTIBLE DOIT ÊTRE INSTALLÉ À L'AVANT DU FOYER. DIMENSION MINIMALE DE 18 po. (457 mm) PAR 36 po. (914 mm) DE LARGE.</p> <p>• MAINTENIR LES MEUBLES ET AUTRES OBJETS À UNE DISTANCE SÉCURITAIRE DU FOYER</p> <p>• ALIMENTATION ÉLECTRIQUE: 115V, 60 Hz</p> <p>• UTILISER SEULEMENT AVEC UNE CHEMINÉE 6 po. (150 mm) DE DIAMÈTRE, MODÈLE ASHT*, S1106*, HT6000*, HT6105* OU AC HOMOLOGUÉE.</p> <p>• PEUT ÊTRE RACCORDÉ SUR UNE CHEMINÉE DE MAÇONNERIE TEL QU'ÉCRIT DANS LE MANUEL D'INSTALLATION.</p> <p>• LES COMPOSANTES UTILISÉES AVEC LE FOYER DOIVENT ÊTRE HOMOLOGUÉES. VOIR LA LISTE DANS LE MANUEL D'INSTALLATION.</p> <p>• REMPLACER LA VITRE AVEC UN VERRE CÉRAMIQUE DE 5mm D'ÉPAISSEUR.</p> <p>• POUR UNE UTILISATION SÉCURITAIRE, INSTALLER CONFORMÉMENT AUX DIRECTIVES DU FABRICANT.</p> <p>• ATTENTION : NE PAS OBSTRUER LES ARRIVÉES D'AIR COMBURANT.</p> <p>• NE PAS FAIRE SURCHAUFFER LE FOYER.</p> <p>• LA PORTE DU FOYER DOIT DEMEURER TOTALEMENT OUVERTE OU TOTALEMENT FERMÉE LORSQUE LE FOYER FONCTIONNE.</p>
<p>INSTALL WITH MINIMUM CLEARANCES TO WALL AS SHOWN IN INCHES</p>  <p>FRONT BACKWALL AND FIREPLACE SIDE</p> <p>FRONT CORNER INSTALLATION</p>	<p>INSTALL AND USE ONLY IN ACCORDANCE WITH THE MANUFACTURER'S INSTRUCTIONS AND LOCAL BUILDING CODES</p> <p>CHIMNEY TYPE: USE ONLY LISTED CHIMNEY MODEL ASHT-5-1106*, HT6000*, HT6105*, AC, 6 in. DIAMETER.</p> <p>SPECIAL METHODS ARE REQUIRED WHEN PASSING THROUGH A WALL OR CEILING. SEE INSTRUCTIONS AND BUILDING CODES.</p> <p>PREVENT CREOSOTE FIRE. INSPECT CHIMNEY CONNECTOR AND CHIMNEY FLUE MONTHLY AND CLEAN IF NECESSARY. DO NOT OVERFIRE. IF DOWNDRAFT CONNECTOR IS USED, INSPECT CONNECTOR GLOWS YOU ARE OVERFIRING.</p> <p>KEEP FURNISHINGS AND OTHER COMBUSTIBLE MATERIALS A CONSIDERABLE DISTANCE AWAY FROM AFFLANCE.</p>	<p>FLOOR PROJECTOR MINIMUM DISTANCE FROM OPENING IN INCHES</p>  <p>FIREPLACE FRONT</p> <p>HEARTH EXTENSION MATERIAL: • 3/8" THICKNESS NON COMBUSTIBLE MATERIAL • OR EQUIVALENTS</p> <p>NP311 Rev. 0</p>	<p>DATE OF MFG.</p> <p>1 2 3 4 5 6 7 8 9 10 11 12 2010-11-12-13-14-15-16</p> <p>SECURITY CHIMNEYS INTERNATIONAL LTD</p> <p> CHEMINÉES SÉCURITÉ INTERNATIONALE LTÉE</p> <p>LAVAL, QUÉBEC, CANADA.</p>

3. THE FIREPLACE

3.1 INTRODUCTION

The BIS Ultima™ CF fireplace is an energy efficient, heat circulating, close combustion fireplace. You will receive a lifetime of comfort and enjoyment from your fireplace provided it is installed, maintained and operated properly.

- Please read these instructions and retain this manual for future reference.
- Before beginning the fireplace installation, consult the local authorities to obtain your building permit and check your local building codes. Install the fireplace only as described in these instructions and using only Security Chimneys International components.
- The BIS Ultima CF is not intended for use with a gas log. Failure to follow these instructions will void the certification and the warranty of the fireplace and may result in an unsafe installation.

3.1.1 *Parts Required*

- Fireplace model BIS Ultima CF
 - Includes the following kits:
 1. Outside air kit
 2. Blower kit with thermo-disc
- Your choice of finishing kit
 1. Louver kit
 2. Clean face obstruction plate kit. **Must be used in conjunction with a gravity vent kit (see section 3.5.1)**

***SEE SECTION 3.4.2 FOR THE ASSEMBLY OF THE FINISHING KITS.**
- Outside air kit (included with fireplace)
- 6" diameter chimney model ASHT+, S-2100+, HT6000+, HT6103+ or AC manufactured by Security Chimneys International only, including:
 - Chimney lengths
 - Elbows (where necessary)
 - Associated components as per these installation instructions

3.1.2 *Additional Equipment (optional)*

- 5" flexible venting system (central forced air kit- Not EPA certified)
- Gravity venting system
- Rigid firescreen
- Blower speed control

3.2 OPERATING THE BIS ULTIMA™ CF

3.2.1 Fuel

The BIS Ultima™ CF fireplace is designed to work best when fuelled with seasoned cordwood. Hardwoods are preferred to softwoods since the energy content of wood is relative to its density. Hardwoods will result in a longer burning fire and less frequent refuelling. A moisture content of 15% to 20% (seasoned) is recommended. Wood that has been cut and split and let to dry under a cover for a period of one year will usually meet that criterion. Excessively wet wood will be difficult to burn and will result in lower efficiency, increased creosoting and deposits on the glass and in the chimney. Excessively dry wood will burn well but will also have higher emissions and shorter burning time.

Do not burn scrap or garbage, treated wood or wood such as driftwood from the ocean which has been exposed to salt or other chemicals. Salt or chemicals can corrode the firebox and chimney. Do not burn large amounts of paper, cardboard, Christmas tree branches or building construction materials. Intense firing with these materials may overheat the fireplace, causing damage to the unit, a fire or even possibly igniting a chimney fire if the chimney is creosoted.

Processed fire logs can be used. Refer to warnings and cautions markings on the packaging prior to use.

3.2.2 First Fires

Before using the fireplace make sure to remove the plastic wrapping on the door. Remove all remaining glue with mild soap.

The first 5 or 6 fires should be small fires of short duration (about 30 to 60 minutes). This will help cure the refractory bricks. The first fires may produce slight smoking due to drying of the paint and steel and any dust accumulated on the fireplace will burn off at this time. It may set off a smoke alarm located in the same room. For this reason the room should be well ventilated for the first few fires.

3.2.3 Building a Fire

To start a fire, place several crumpled up balls of newspaper in the firebox. Place small dry pieces of kindling on top of the paper, criss-crossing the kindling so that there are air spaces in between. Keep the fuel far back enough so that air can get underneath. Open the air controls fully and light the newspaper. Once the newspaper and the kindling are well ignited, close the door. Once the kindling fire is well established, cordwood can be added. (See Primary Air Combustion Control section for proper operation of the air controls)

The unit will burn best with 2-3 pieces of cordwood spaced 1 to 2 inches apart and allowing air to get under the fuel. Criss-crossing or arranging the fuel so that air can get underneath, will help the fire to get started easily. The unit should be operated with the air control fully open long enough to get the cordwood well ignited.

3.2.4 Primary Air and Air Boost Controls

There is no flue damper in the BIS Ultima™ CF fireplace. As is common with air tight stoves, the combustion air control sets the flow of air entering the firebox. This allows for a more precise control of the fire. The combustion air control is located below the door on the left side. The main source of air (primary air) entering the firebox can be diminished by moving the air combustion control from left to right. The primary air is fully opened when the air control is completely moved to the left. The air control device can also be used to add an extra boost of air especially during fire start up and reloading of the unit. Pulling the air combustion control will induce an air boost at the base of the fire allowing an easier fire start up. When the fire is well established, the control can be pushed forward to shut down the air boost allowing for a longer burn time. The combustion air control should be in the closed position (primary air and air boost) when the fireplace is not in use. This will minimize air leakage up the chimney. The combustion air control should be opened before opening the door to minimize the possibility of back draft coming into the room.

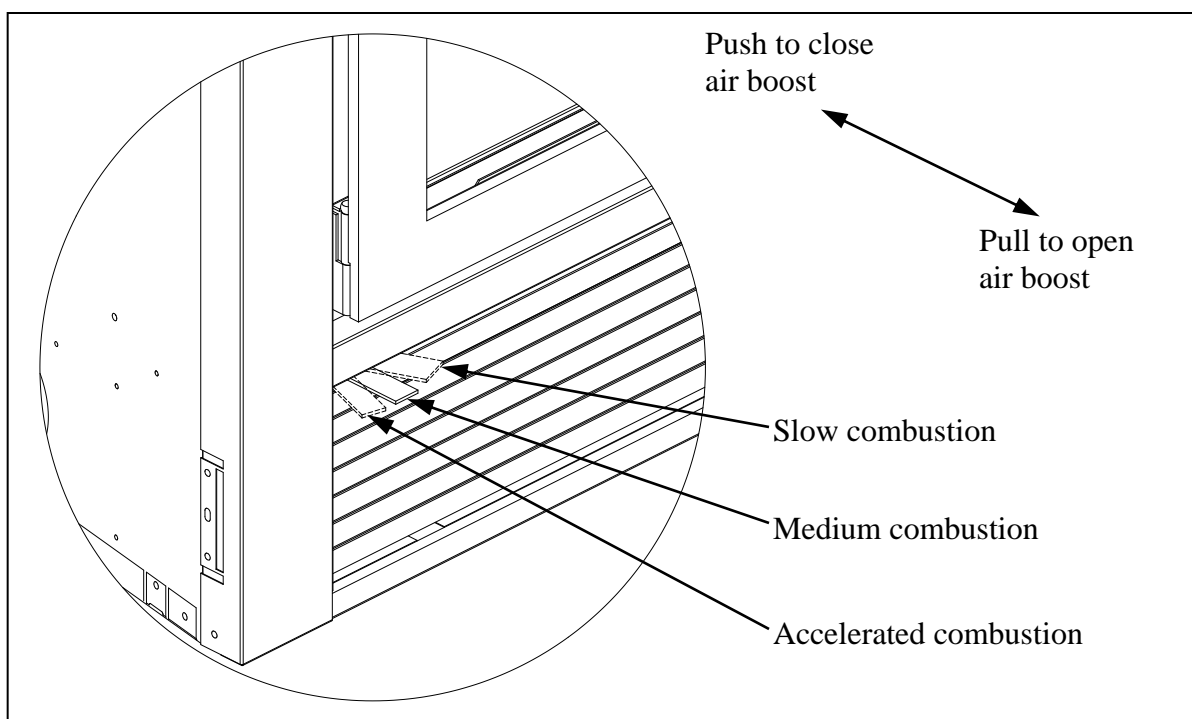

Figure 1

3.2.5 Accelerated Combustion

The maximum heat output for the BIS Ultima CF fireplace is achieved by burning with the door closed and the combustion air opened and pulled back. By this method, the BIS Ultima CF fireplace can produce up to 55,000 BTU of heat per hour. However, it will be necessary to reload with wood every one or two hours. This is the least efficient method of burning the BIS Ultima CF fireplace.

Use caution when firing with the combustion air control wide open. Only burn cordwood must be burned this way. Small dry pieces of softwood and construction scraps will burn very intensely using this method and may damage the firebox.

3.2.6 Medium Combustion

This is the recommended mode of operating the BIS Ultima™ CF fireplace and should be the one normally used since it will deposit the least amount of creosote on the glass and in the chimney. The combustion air control must be 3/4 closed and pushed forward to close the air boost. The precise setting will depend on many factors, including chimney length and the moisture content of the wood.

For instance, a long chimney will necessitate closing the damper more. To obtain the proper combustion, close the damper completely, then open it about 1/4" to 1/2". Three medium size pieces of wood should be burning on a bed of hot coals. The heat output will be approximately 30,000 BTU per hour and the loading time will be about every 3-4 hours. Softwoods may be burned using this method but the time will be substantially reduced.

3.2.7 Slow Combustion

When the air combustion control is completely closed, the fireplace is in a slow combustion phase. If the hearth is hot enough, slow combustion will not stop the fire, but there will be a noticeable change in the flame pattern. The flames will be slow and may appear dirty if the wood is too wet (moisture content of 20% and more). Do not allow the wood to burn without flame, since this will produce excessive creosote in the unit.

Creosote may accumulate on the glass door. This method of burning should be used only after operating the BIS Ultima CF fireplace with the air control opened to produce a hot fire for about an hour or at medium pace for at least 3 hours. Slow combustion can be used at night in order to reduce the heat output and to prolong the burn. The loading time will be between 6-8 hours.

3.2.8 Refuelling For Best Performance

The BIS fireplace will operate best if attention is given to operating the unit with the damper fully opened after refuelling in order to bring the firebox and the chimney system up to their optimum operating temperature. Combustion efficiency is relative to firebox temperature. A temperature of 500° C and up, with a visible flame, in the upper part of the firebox indicates a maximum efficiency. To obtain this temperature, the fireplace must be operated with the primary air and air boost controls fully opened during 10 to 20 minutes after reloading, depending on the heat and on the moisture content of the wood. Once you have reached the desired temperature, the air boost can be closed and the primary air set to a medium setting. You know you have reached the desired temperature when, closing the primary air control, you can see a flame at the top of the firebox. The benefit of this technique will be cleaner glass, less creosoting, greater efficiency and the most pleasing fire for your enjoyment. If your fireplace is equipped with a central forced air system, make sure the central blower is turned off during reloading to avoid smoking problems.

3.2.9 Smoking – Causes and Troubleshooting

To reduce the likelihood of smoking when opening the door, set the combustion air controls to the left before opening the door. Your fireplace has been designed and tested to provide smoke free operation. Occasionally, there may be a small amount of smoking upon lighting the fire, until the chimney heats up but this should not continue. If the fireplace continues to smoke it is probably for one of the following reasons:

A. Negative pressure in the house

As the fire burns, air goes up the chimney. This air must be replaced through leakage into the house or through the outside air duct. When operating the BIS Ultima™ CF fireplace, open a nearby window temporarily to check if there is adequate air supply replacement.

B. Fans operating (e.g.: range hood)

These fans draw air out of the house and may actually cause a negative pressure in the house. Turn off all fans and open a nearby window to determine if this is the cause of the problem.

C. Wet wood

Wet or tarred wood will smoulder and smoke instead of burn properly.

D. Dirty or blocked chimney

Check to make sure the chimney is clear and clean.

E. Chimney not long enough

The minimum chimney height is 12 ft. not including the fireplace height. The chimney must extend at least 3 feet (915 mm) above its point of contact with the roof and at least 2 feet (610 mm) higher than any roof or wall within 10 feet (3 m) of it. When installed with offsets, the minimum chimney height is 15 ft. Additional height will increase draught and will decrease the tendency to smoke.

F. Poor chimney draft

With no fire, there should be sufficient draught to exhaust cigarette smoke introduced under the baffle. Chimneys installed against an outside wall without protection may generate back draught problems which will cause start-up problems. To prevent this, open a nearby window, roll up a piece of paper and light it. Then, hold it in the upper part of the firebox to warm up the chimney. Wait until the draught is sufficient and then start the fire.

G. Blower for central forced air kit operating

Make sure that the blower is at the "off" position when you open the fireplace door for reloading.

IMPORTANT NOTES

- A. Do not block the hot air vents to the fireplace as this will cause the fireplace to overheat.
- B. Never start a fire using gasoline, kerosene, charcoal lighter fluid or any other combustible liquid.
- C. Do not burn coal. The sulphur in coal will corrode the firebox.
- D. Do not burn driftwood which has been in the ocean or salt water. The salt will corrode the firebox and chimney.
- E. Do not burn wood in the area in front of the grate.
- F. Do not abuse the unit by burning paper or cardboard or construction material such as pressed wood, plywood or lumber.
- G. Do not allow the wood to smoulder or burn without flame, since this will produce excessive creosote in the unit.

3.3 MAINTAINING YOUR BIS ULTIMA™ CF

3.3.1 *Creosote*

When wood is burned slowly without a flame, it produces tar and other organic vapours which combine with expelled moisture to form a black deposit called creosote which accumulates on the flue lining. When ignited, this creosote makes an extremely hot fire. If the creosote accumulation is large, a creosote fire in the chimney can damage the chimney and overheat the surrounding wood framing. Creosote formation in a chimney can be minimized by making sure there is always visible flame burning, avoid smouldering fires and by proper refuelling techniques.

3.3.2 *Chimney Maintenance*

Regular chimney inspection and maintenance combined with proper operation will prevent chimney fires. Keep your chimney clean. Do not allow more than 1/16" creosote build up in your chimney. The amount of creosote will depend on variables such as frequency of use and type of fire. We recommend that you:

- A. Initially inspect the chimney system weekly. From this, you will learn how often it will be necessary to clean your chimney.
- B. Have your chimney cleaned by a qualified chimney sweep. If you wish to clean it yourself, we recommend using a stiff plastic or non-metallic brush. If a metal brush is used, its size should be slightly smaller than the flue to avoid damaging the chimney. Do not use a brush that will scratch the stainless steel interior of the chimney.
- C. Do not expect chemical cleaners to keep your chimney clean. The rain cap can be removed for inspection and/or cleaning of the chimney.

3.3.3 Top Baffle Removal Prior to Cleaning the Chimney

Before starting to clean your chimney, we recommend that you remove the top baffle to avoid creosote dust collection at the top of the baffle. Follow these steps to set the top baffle out of the way:

1. Remove the side refractory holder. They are located at the top of the refractory.
2. Lift the front baffle.
3. Slide the back baffle under the front baffle. You now have access to the chimney.

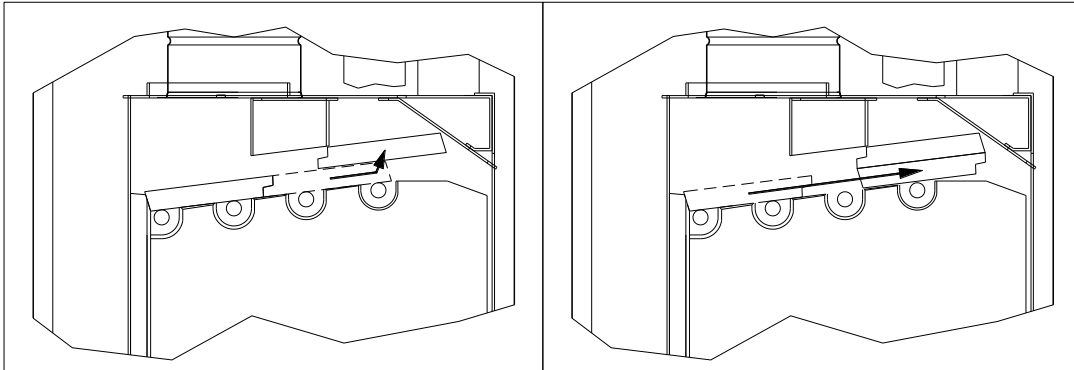

3.3.4 Dealing with a Chimney Fire

Regular chimney maintenance and inspection can prevent chimney fires. If you have a chimney fire, follow these steps:

1. Close the fireplace door and the combustion air controls.
2. Alert your family of the possible danger.
3. If you require assistance, alert your fire department.
4. If possible, use a dry chemical fire extinguisher, baking soda or sand to control the fire. Do not use water as it may cause a dangerous steam explosion.
5. Check outside to ensure that sparks and hot embers coming out of the chimney are not igniting the roof.
6. Do not use the fireplace again until your chimney and fireplace have been inspected by a qualified chimney sweep or a Fire Department Inspector.

3.3.5 Finish Door Casing Care

Use a glass cleaner and a soft cloth to polish the casing. Do not use abrasives such as steel wool, steel pads or an abrasive polish for they may scratch the casing's finish.

3.3.6 Ashes

Remove ashes only when the fire is out and the ashes are cold (24 to 48 hours after the fire is out).

3.3.7 Refractory Replacement

The intense heat of the fire will normally cause hairline cracks in the refractory. These cracks can be minimized by proper curing as described in "First fires". They will not normally diminish the effectiveness of the refractory. If large cracks develop, then the refractory should be replaced. To replace the refractory bricks, follow these steps:

1. Remove the front refractories
2. Remove the bottom refractory
3. Remove the left side refractory
4. Remove the right side refractory
5. Remove the back refractory
6. Remove the front ceramic baffle
7. Remove the rear ceramic baffle

To install the new refractories, follow the above steps in reverse.

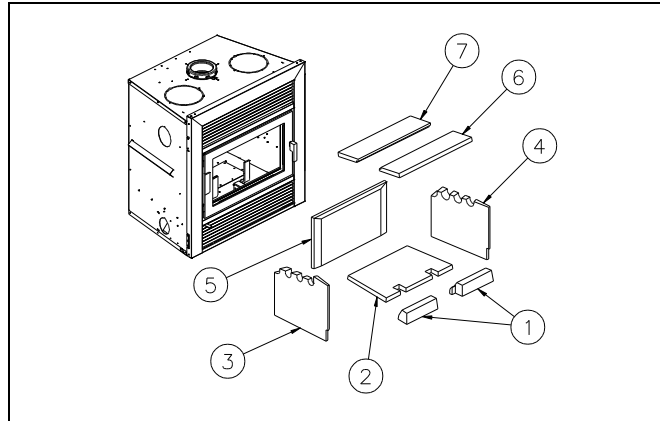

Figure 2

3.3.8 Door Installation

Your fireplaces door has been factory installed and adjusted.

To remove the door simply unscrew the top hinge from the door than lift the door, without touching the trim over the door, to disengage the male part of the bottom hinge from the female part.

The door adjustment has been set at the factory. If the fit is still not perfect, you can adjust the door using the hinge screws.

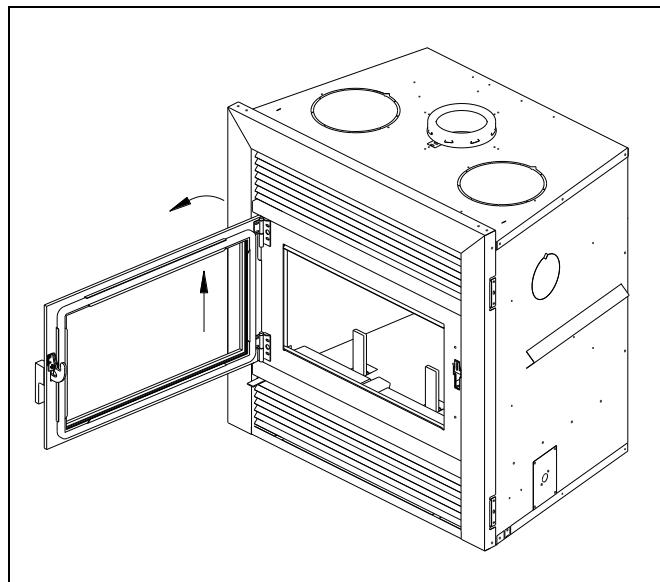

Figure 3

3.3.9 Door Adjustment

The door may need to be adjusted to be completely airtight. The gaskets' air-tightness can be adjusted using the adjustment screw located on the right side of the fireplace façade. (An Allen key #1/8 – not supplied - will be necessary for this adjustment)

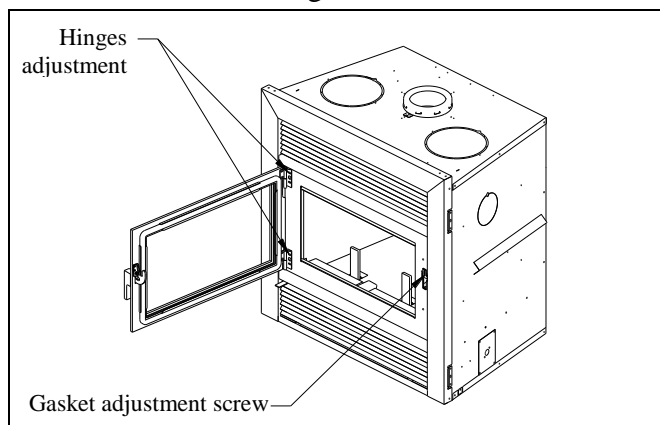

Figure 4

3.3.10 Glass Care - Replacement

The glass used for the BIS Ultima™ CF fireplace is a high temperature ceramic glass (1400° F). If the glass breaks, it must be replaced with an identical ceramic glass. Tempered glass or ordinary glass will not withstand the high temperatures of the BIS Ultima CF fireplace. Replacement glass should be purchased from a Security Chimneys International dealer (see "Replacement Parts", page 34). Do not operate the unit with cracked or broken glass.

3.3.11 Glass Care - Cleaning

The BIS Ultima CF fireplace is designed to keep the glass clean under normal operating conditions. If the BIS Ultima CF fireplace is operated continuously with the combustion air controls closed, the glass will tend to get dirty unless the fuel, firebox and glass are maintained at hot temperatures (see "Refuelling for best performance"). To clean the glass, there are a number of specially designed cleaners. Your authorized Security dealer can recommend a suitable cleaner which is available in your area. Regular household glass cleaners will not clean creosote. Do not use abrasives such as steel pads, steel wool or oven cleaner as they will scratch the glass.

DO NOT USE CHEMICAL GLASS CLEANERS ON PAINTED SURFACES AS IT MAY CAUSE THE PAINT TO PEEL.

CAUTION: Do not allow window cleaner to get in contact with door gasket or paint on the facade. Once closed, contact of glass cleaner with the fireplace facade can provoke paint peeling off.

3.3.12 Gasket Replacement

Remove the door from the unit (see page 10) and lay them on a clean unabrasive surface. To replace the gasket, first remove all of the old gasket and gasket cement. Make sure that the surface is totally clean before applying new cement (a high temperature silicone caulking rated at 500°F, 260°C, is suitable) or adhesion problems may result. Apply gasket cement to the gasket channel and install the new gasket. This replacement part is available from your Security dealer in the following dimensions:

<u>Gasket</u>	<u>Length</u>	<u>Dimensions</u>	<u>Part Number</u>
Around glass	74"	3/16"x1po	SR1685J
On door frame	77 3/4"	5/8" dia.	SR1823P

3.4 FIREPLACE INSTALLATION

3.4.1 *Locating the BIS ULTIMA™ CF*

- A. The best location to install your fireplace is determined by considering the location of windows, doors, and the traffic flow in the room where the fireplace is located, allowing space in front of the unit for the hearth extension and the mantel, and taking into consideration the location of the hot air ducts (optional), outside air kit and chimney. If possible, you should choose a location where the chimney will pass through the house without cutting floor or roof joists (see fireplace dimensions page 13).
- B. Usually, no additional floor support is needed for the fireplace. The adequacy of the floor can be checked by first estimating the weight of the fireplace system. Weights are given in the appendix. Next, measure the area occupied by the fireplace which is normally 36" X 24 ½". Note the floor construction and consult your local building code to determine if additional support is needed.
- C. The BIS Ultima™ CF fireplace may be installed directly on the floor or on a raised base (for proper guidelines, refer to "**Hearth Extension Requirements**") and a minimum of 6'8" measured from the base of the appliance to the ceiling is required.
- D. When selecting the location, the chimney outlet position and the direction of the wind are important factors affecting the chimney performance. To allow a maximum draft and to reduce wind turbulence, the chimney must:
- Penetrate the highest part of the roof.
 - Be installed as far as possible from roof offsets, trees or any other obstructions that may cause wind turbulence and back drafts in the chimney.
 - The least amount of offsets (elbows) possible.
- Note: a maximum of 2 offsets is allowed.

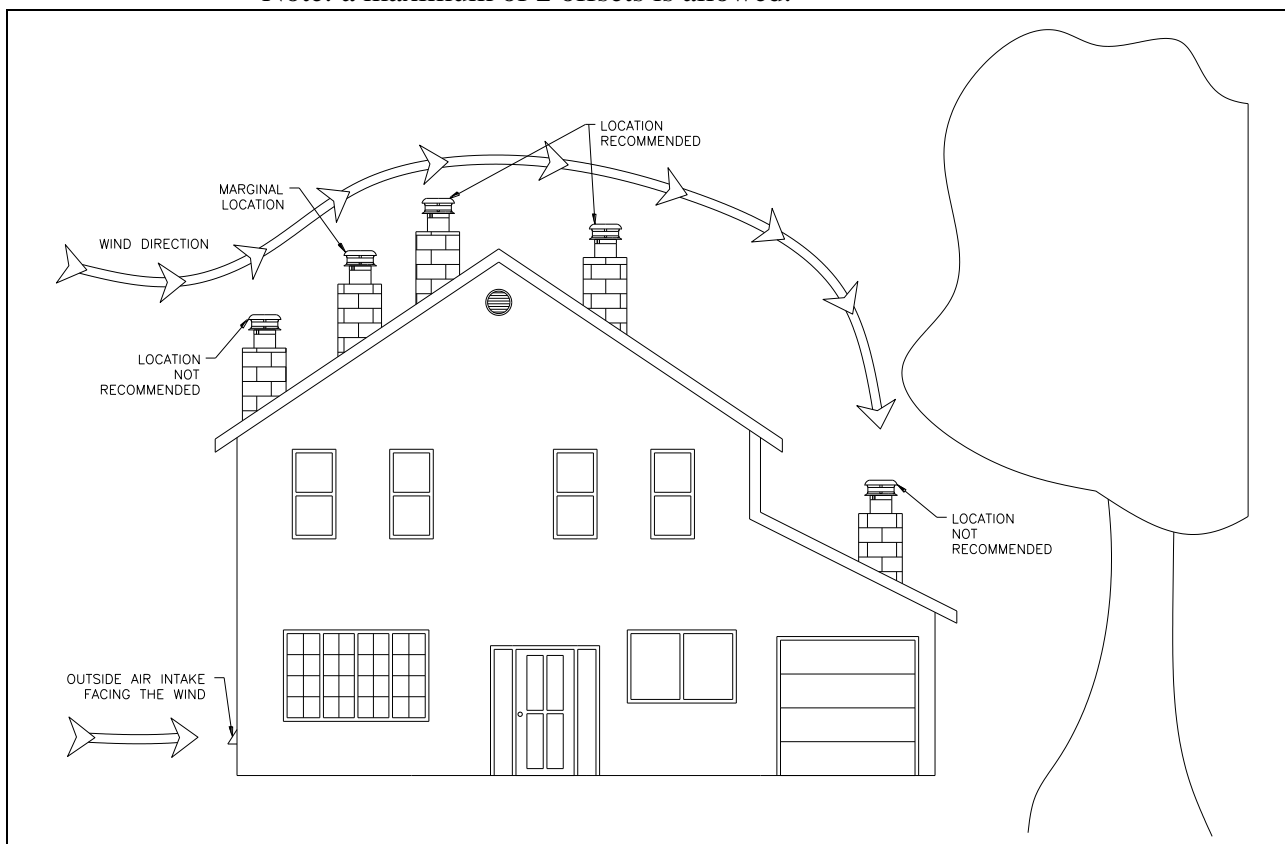

3.4.2 Installing the Finishing Kits

The BIS Ultima™ CF requires the installation of a finishing kit. Two options are available:

1. Louver kit (part number: LOUVRECF)
2. Clean face kit (part number: CAPPINGCF)

3.4.2.1 Installing the louver kit

The louver kit includes two identical louvers assembly. The louvers must be oriented so the angular parts of the grills are towards the front and the bottom and the cotter pins are at the bottom.

Insert the top of the louver rods in the top trims holes. Then insert the bottom of the rods in the holes at the bottom of the opening. The cotter pins will rest on the bottom trim in order to vertically locate the louvers.

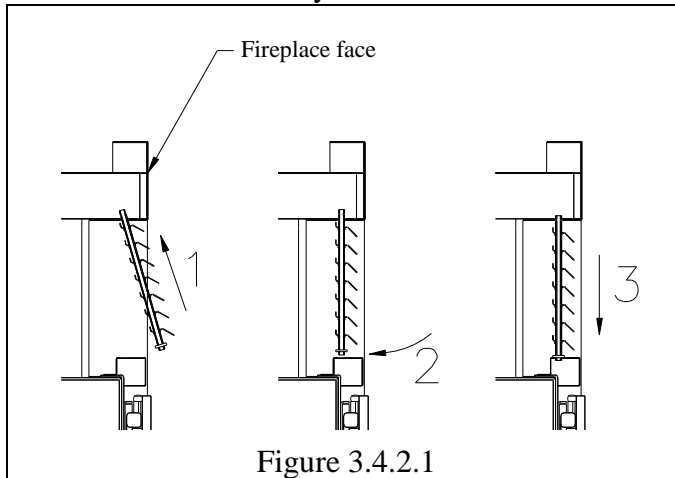

3.4.2.2 Installing the clean face kit

The clean face kit includes four parts. Two trims, left and right, are used to cover the edge of the finishing material on the sides, and two obstruction plates to cover the top and bottom openings allowing to install the finishing material closer to the door.

WARNING: The bottom obstruction plate is designed to leave an opening area for the convection air to circulate and cool your fireplace. NEVER BLOCK THIS AIR SPACE TO AVOID OVERHEATING THE FIREPLACE AND POTENTIALLY CAUSE A FIRE IN YOUR HOME.

See section 3.5.1 to install the gravity vent kit.

Installation Steps:

1. Install the side finishing trim, making sure to differentiate the left from the right. The shortest end bend should be towards the bottom.
2. Install the right side trim. The full length flat part must rest against the right side face frame, the center bend must be oriented towards the outside of the unit and the bends towards the inside. The end bend on top must be pushed between the crossing trim and the right side frame. This can be difficult because these are close together to allow a good look when using the louver kit. The part will be fixed in place when installing the other parts.
3. Repeat with the left trim.

4. Install the top obstruction plate in the top opening, oriented so the insulation faces the inside and the 1/2in. bend is towards the outside and the bottom. The part is pressure installed to keep from using screws that could interfere with your finishing material. Place the bottom bend on the lower trim and push on it to insert the top bend. Push on the part so the ends lie well on the fireplace face.
5. Install the bottom part the same way. Make sure to push the part to the bottom to leave the required air space.
6. Use sheet metal screws on all 4 corners to secure the installation.

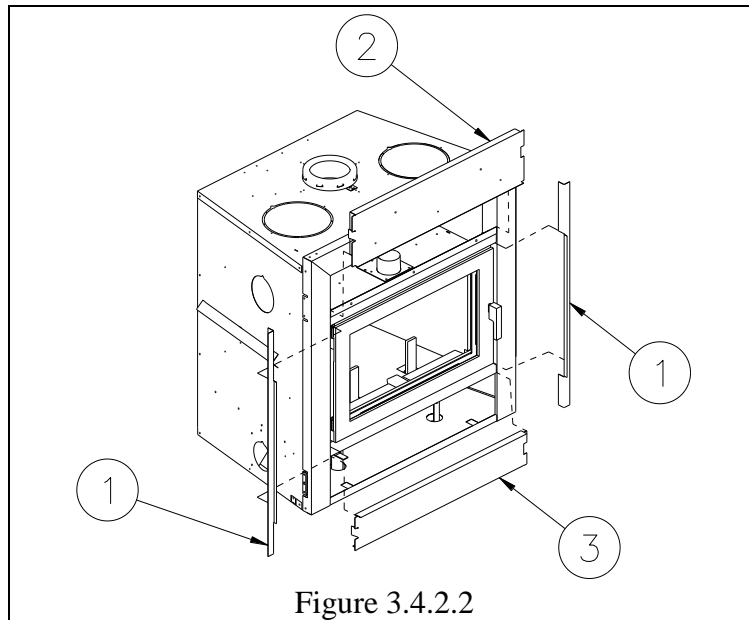

3.4.3 Hearth Extension Requirements

The BIS Ultima™ CF fireplace may be installed directly on a combustible floor; however, the combustible floor in front of the fireplace must be covered with a non-combustible material (tile, marble, stone, etc.). The supplied safety metal strip must be positioned as follows: One half under the front of the fireplace and the other half must extend on the floor over which the hearth extension will be built (figure 5b).

* The safety metal strip must cover the entire width of the fireplace.

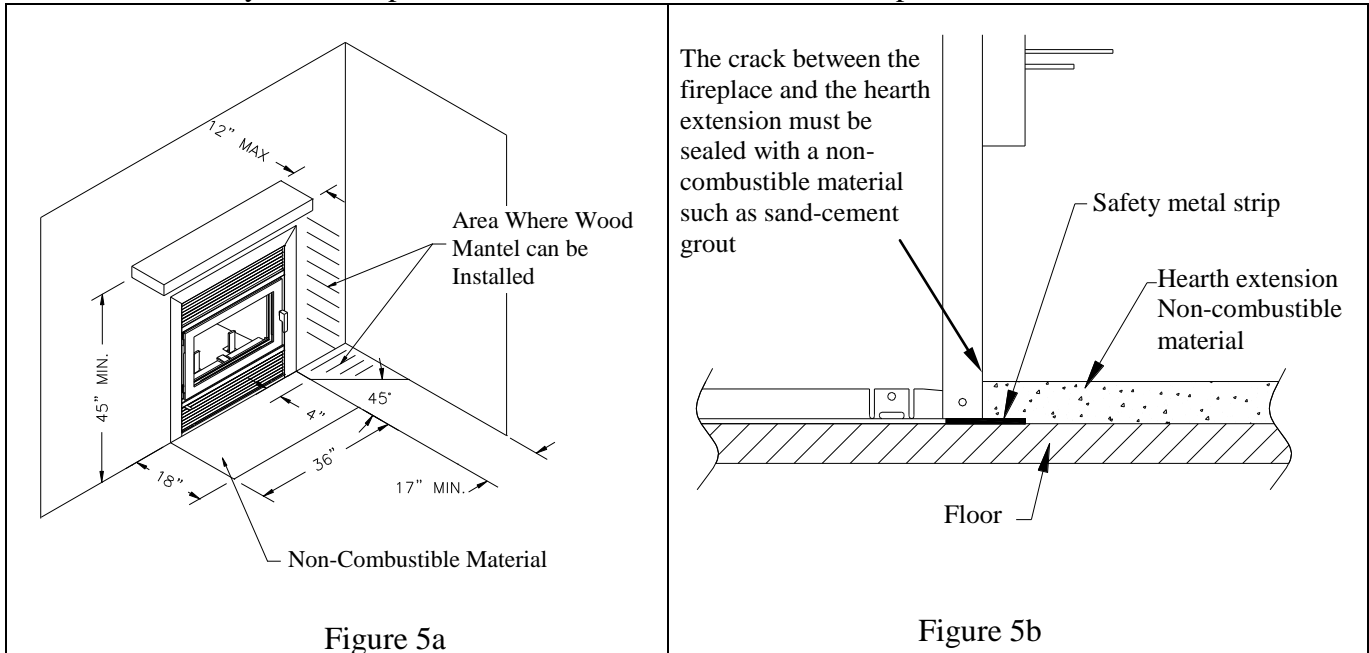

Elevated fireplaces (Figure 6)

Elevated fireplace installations require a special 'Z' metal safety strip (field provided), in place of the safety metal strip shown on Figure 5b. The safety strip should extend the full width of the fireplace. When more than one safety strip is used they must overlap by a minimum of 1".

Hearth extension of an elevated fireplace must respect the same minimal dimensions as a fireplace installed directly on the floor (figure 5a).

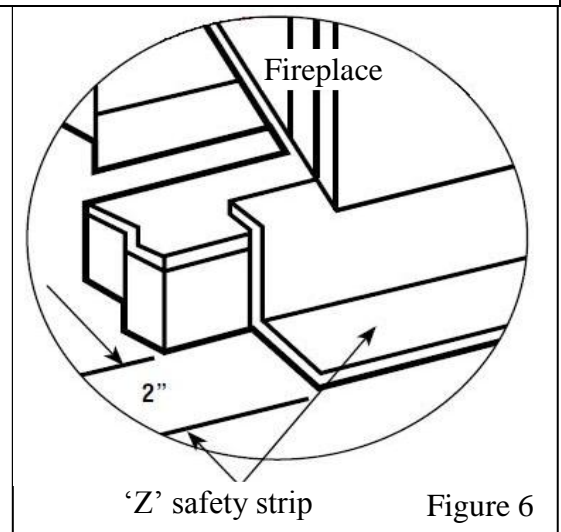

3.4.3 Framing, Facing and Mantel

The construction of the framing, facing, and mantel must be in accordance with the standards and the following illustrations (figures 7 to 11):

A. Frame the fireplace using 2" x 3" or heavier lumber.

- B. **WARNING:** Combustible materials cannot be used in the space directly above the fireplace, except for the studs above the facade that support the facing and mantel. This area must remain empty for **a height of 6'8" (2032 mm) measured from the base of the appliance.**
- C. Frame the fireplace with vertical studs at the sides of the fireplace running from floor to ceiling (see figure 8). If combustible facing is to be used, position the studs back, from the front edge of the fireplace, a space the thickness of the facing material so that the facing can be installed flush with the fireplace facing. Frame headers between the vertical studs only as follows:
- Place 2" x 3" or 2" x 4" headers, only along the upper part of the front, side and back faces. Do not put wood or any combustible material within the area above the fireplace except on the front facing.
 - Place headers only as required to support the facing and mantel.
- D. **WARNING:** The fireplace must not be in contact with any insulation or loose filling material. Cover the insulation with drywall panels around the fireplace.

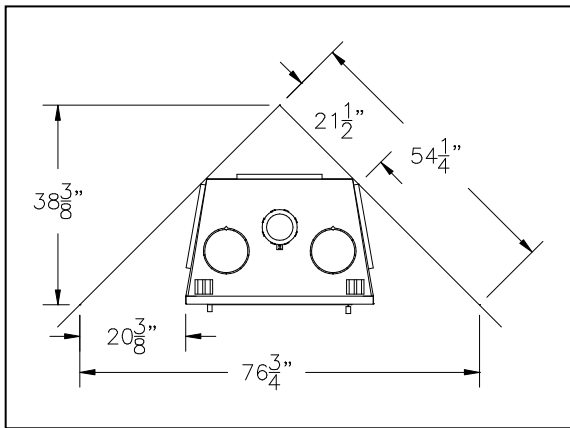

Figure 7

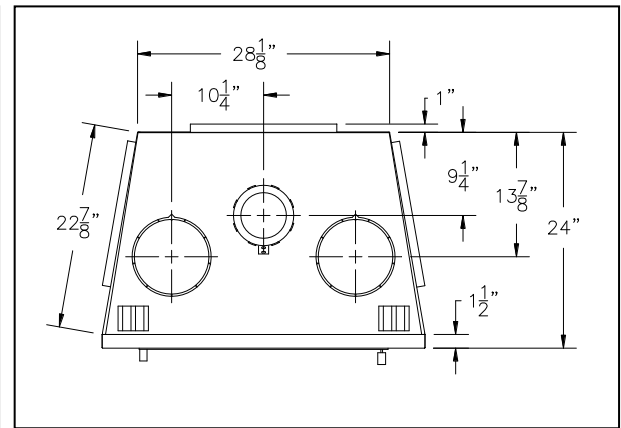

Figure 9

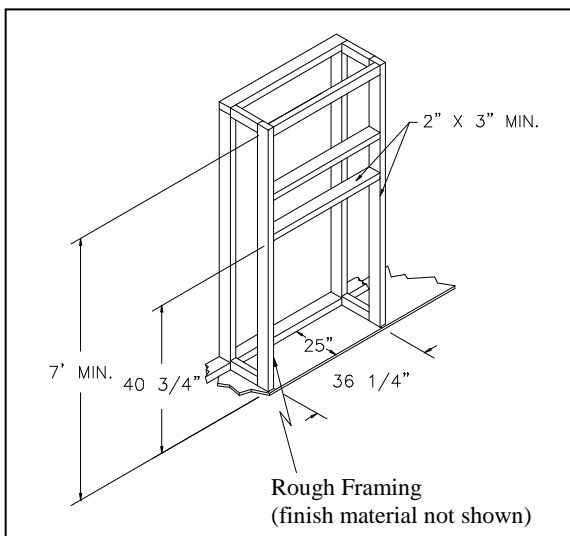

Figure 8

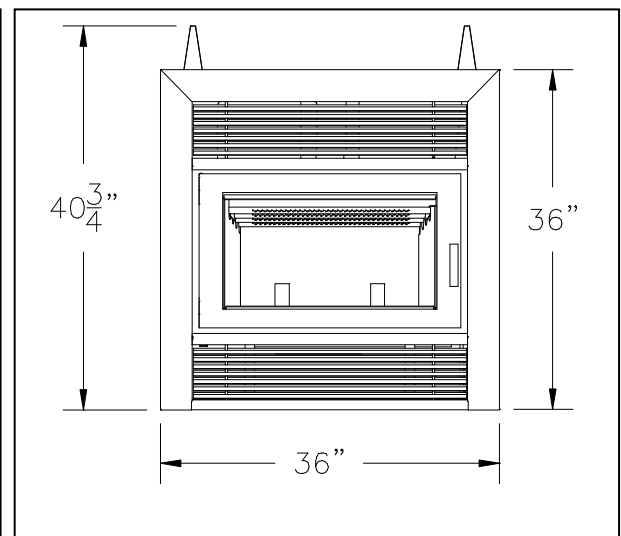
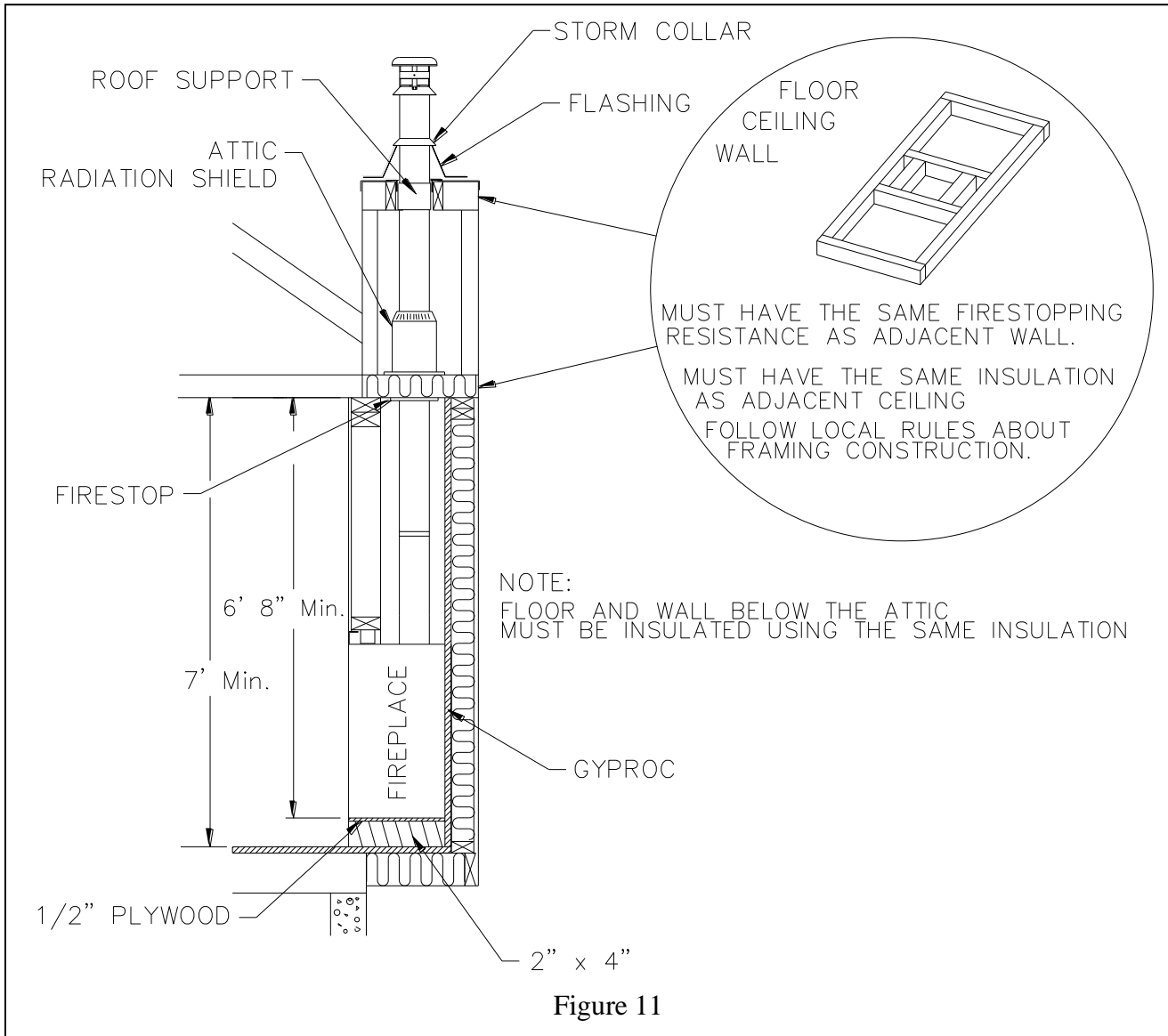

Figure 10

INSULATED CHASE CONSTRUCTION



Nailing Flanges

Four nailing flanges are provided to secure the fireplace on the floor (see figure beside). Bend the nailing flanges down so each flange is flush with the floor, then using nails or screws, secure the fireplace to the floor (2 places each side). The heads of the screws must be large enough to cover the holes on the nailing flanges.

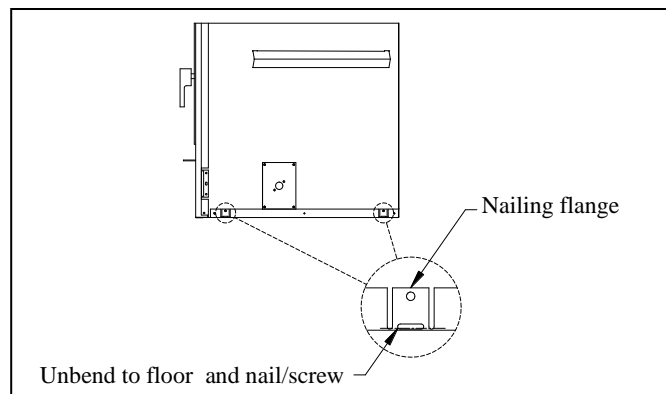

Facing

The facing installation method depends on your finishing kit choice.

1. Facing with the louver kit

The 2x3 framing must offset to the back by a distance equivalent to the thickness of your facing material so the surface of the facing be aligned with the fireplace face. Combustible materials must be aligned with the fireplace face and can not overlay on the fireplace front (black steel face of the fireplace) (see figure 12 and 12a).

NOTE: non-combustible materials like brick, stone or ceramic tiles may be overlay on the fireplace front (see figure 12b).

2. Facing with the clean face kit.

The 2x3 framing must offset to the back by a distance equivalent to the thickness of the gypsum.

Combustible materials must be installed to be aligned with the fireplace front and can not overlay on the fireplace front (black steel face of the fireplace) (see figure 13 and 13a). Non-combustible materials such as brick, stone or ceramic tile can project in front of and onto the fireplace facing up to the tiling flange on the clean face kit (figure 13b).

Mantel

The mantel must be installed at least 45" (1143 mm) above the base of the fireplace (figure 12).

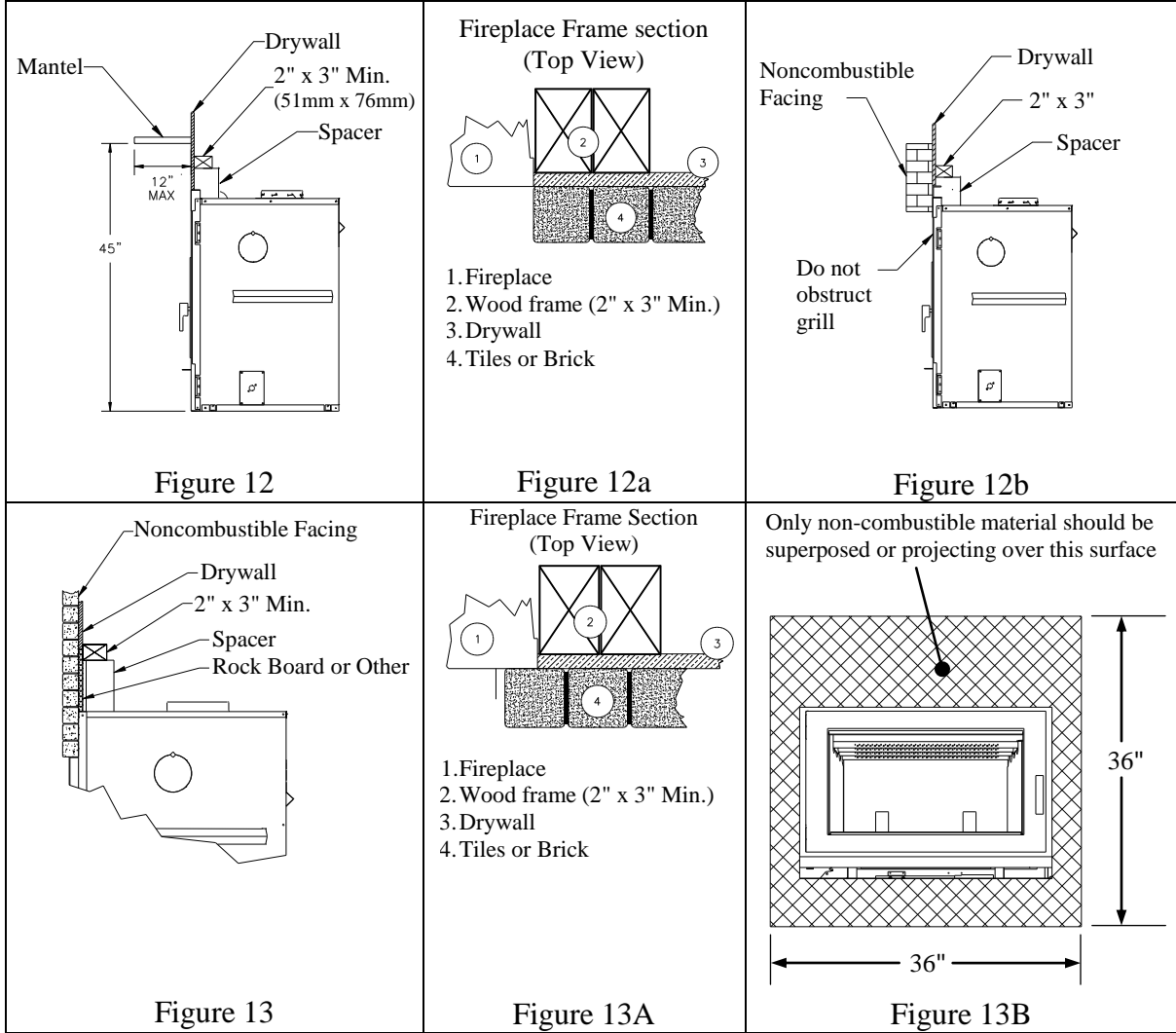

3.5 HOT AIR DUCTING INSTALLATION

Different hot air ducting systems can be installed with the BIS Ultima™ CF:

- Gravity kit
- Forced air kit

3.5.1 *Gravity Kit*

Double hot air outlet including: (See Fig.15)

- 2 telescopic lengths 8" I.D.
- 2 90° elbows 8" I.D.
- 2 hot air outlet kits (grill and frames)
- 2 adaptors

See components list page 33.

The only fan that can be used with the gravity kit is the UZY6.

The gravity kit must be used with the clean face kit to allow hot air flow that would normally come out of the top louver. To do so, follow the steps below:

- Install the clean face kit making sure that the insulation strip is installed inside.
- The fireplace façade can be covered with non-combustible material (fig. 18).

WARNING: both pipes of the double hot air outlet must be installed. Any other installation may cause fire and void warranty.

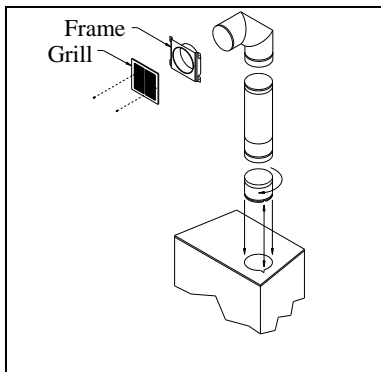

Figure 15

The safety rules for hot air ducting gravity kit installations are the following:

Minimum height*	68" (1727 mm)
Maximum length	See figure 16

The height of the louver must be measured from the base of the BIS to the middle point of the louver.

When installing the double outlet system, the hot air outlets can be installed in the same room as the fireplace, or one or both of the outlets can be installed in adjacent or upper rooms. Installing the ducts at different elevations will tend to exhaust more heat out of the higher outlet (figure 16).

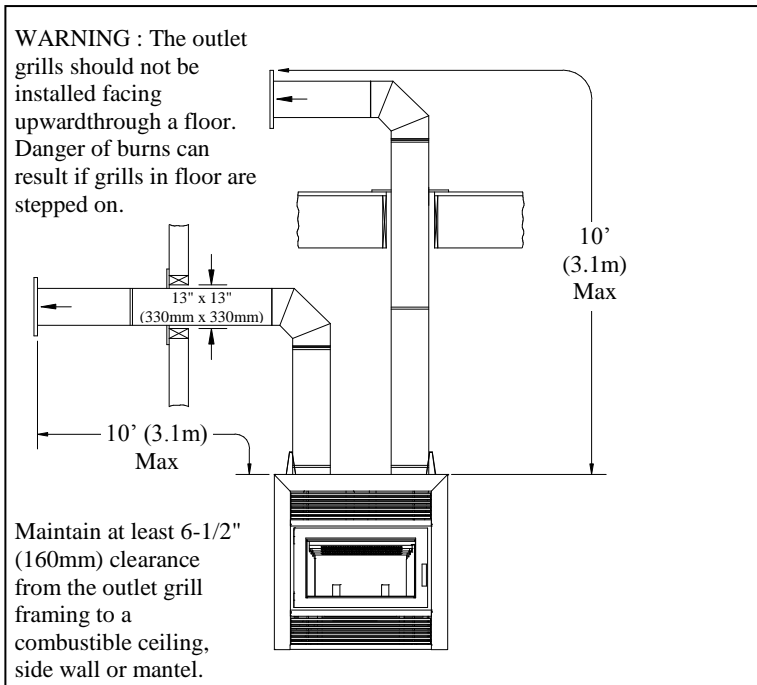

Figure 16

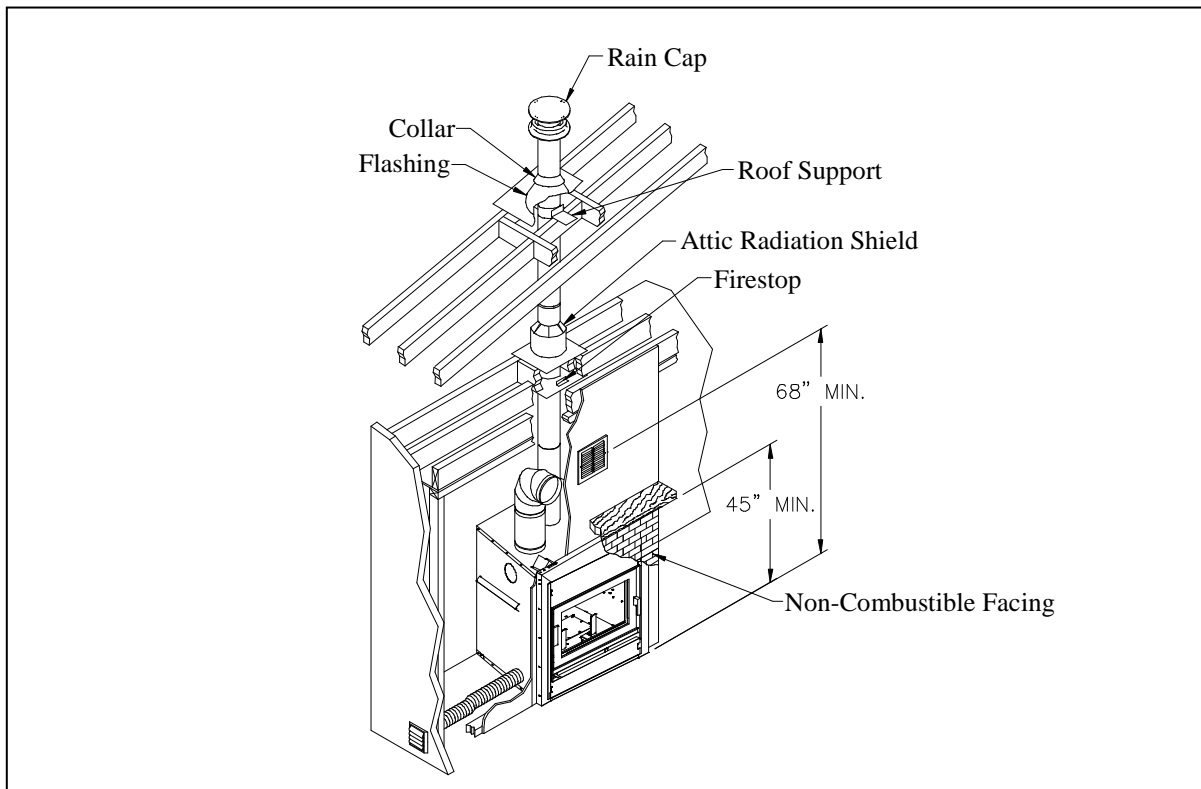

Figure 18

The duct system must be installed respecting the following:

1. Remove the plates closing up the 8" dia. holes on top of the fireplace. Then, cut the insulation in order to obtain two 8" dia. openings. Fix the adaptors on the fireplace openings by turning clockwise (figure 15).
2. Maintain at least a 2" (50 mm) clearance between the ducts and any combustible material; the required hole size is 13" x 13" (330 mm x 330 mm).

Exception #1: For the grills, the framing can be 10 3/4" x 10 3/4" (275 mm x 275 mm) to provide the clearance as required by the integral spacers on the double outlet duct system.

3. The maximum number of elbows in a run of duct is two.
4. Maintain at least 6 1/2" (160 mm) clearance from the outlet grill framing to a combustible ceiling, side wall or mantel.
5. When traversing a combustible wall or floor, a firestop must be installed at the wall or floor penetration. The hole size must be 13" X 13". (330 mm x 330 mm)
6. Do not connect the hot air ducts to a central heating system. Malfunction of the heating system's fan will cause the fireplace to overheat. A furnace duct is only single wall and not double wall as is required for the BIS Ultima™ CF fireplace hot air exhaust.
7. Use only Security Chimneys International grills and components as described in this manual. Other grills or registers, for example, may be too restrictive and may overheat the fireplace or ceiling.
8. Do not use insulated flexible ducts as they will overheat.
9. Do not use tees or any other components than the ones specifically listed here.
10. All ducts must extend upwards or horizontally. Never route the ducting downwards.
11. The hot air outlet grills must be installed with the louvers pointing downwards in order to prevent overheating adjacent ceilings.
12. Always install the two outlet grills when using the double hot air outlet kit and blocking the upper louver of the fireplace.

3.5.2 Central Forced Air Kit (Not tested under EPA certification)

The knock-outs provided on the back and on the sides of the BIS Ultima™ CF fireplace allow the connection of insulated flexible pipe which enables you to heat adjacent rooms up to 50 feet from the fireplace.

The ducting system must be installed as described below:

- A) Fix the adaptor at the back and/or the side of the fireplace by twist-locking the adaptor to the fireplace. You can use more than one outlet on the fireplace (figure 19).
- B) Attach the 5" flexible pipe, using the collars provided. **Important:** Make sure that the plastic wrapping around the flexible pipe will not be in contact with the fireplace.
- C) Route the flexible pipe to the chosen location. The ducting system can be installed either in an upper room or in a lower room.
- D) Attach the flexible pipe to the fan, using the collars (figure 20).
- E) Fix the back draft damper to the fan outlet.
- F) Attach a flexible pipe to the fan / flexible pipe adapter (square to round) and stretch it up to the location where the heat is required.
- G) At that point, the flexible pipe can be attached to any air distribution grill. It is possible to connect a flexible pipe to a central heating system. Make sure the pipe will be connected to the warm air supply duct, not to the return air duct (figure 21).
- H) Install the *blower heating and cooling thermostat* (HCTW) in that part of the house to be heated by the hot air duct. The thermostat can be switched to a cooling thermostat and installed in the same room as the unit. This thermostat will turn on the blower when the room where the fireplace is located becomes too hot.

This option requires electricity. Make sure that the connections to the fan have been made according to the local codes and comply with their requirements (see instruction provided with the thermostat).

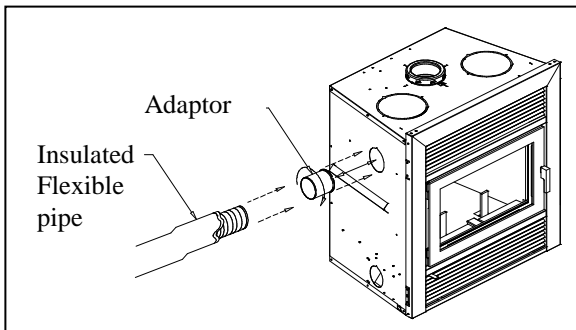

Figure 19

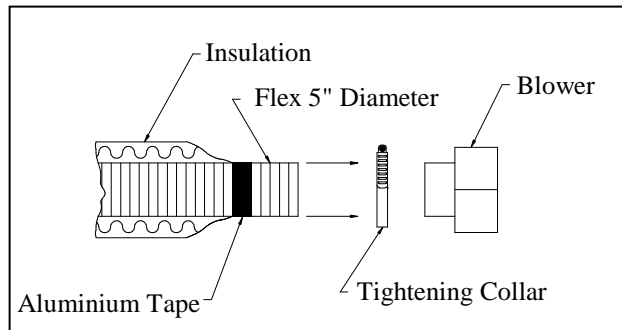

Figure 20

3.6 **OUTSIDE AIR KIT (Optional)**

During operation, the fireplace requires fresh air for combustion and draws air out of the house. It may starve other fuel burning appliances such as gas or oil furnaces. As well, exhaust fans may compete for air, causing negative pressure in the house, resulting in smoke entering the house from the fireplace. This situation is aggravated in modern airtight houses. To overcome this problem, we strongly recommend that you **install an outside air assembly**. **Check with local authorities having jurisdiction in your area, it may be mandatory.**

NOTE: Should you decide not to install the outside air assembly, proceed as follows

- Remove the bottom grill. The air box is located on front left and is on a slant. Unscrew the four screws holding the inside air box covering plate and remove it.

3.6.1 ***Outside Air Installation***

The outside air assembly may be installed according to the following requirements:

- A) Duct length should be kept to a minimum. The maximum length of a 4" I.D. (100mm) insulated flexible duct is 20 ft. (6.1 m). The duct can be extended to a maximum of 40 ft. (12 m) using a 6" I.D. (150mm) insulated flexible duct (See note below).
- B) The air intake register must not be installed more than 10 ft. (3050 mm) above the base of the fireplace.
- C) The fresh air must come from outside the house. The air intake must not draw air from the attic, from the basement or garage.
- D) The air intake should be installed where it is not likely to be blocked by snow or exposed to extreme wind and away from automobile exhaust fumes, gas meters and other vents.
- E) The duct and register may be installed above or below floor level.

The following components are required:- Outside air kit (UZI)

- 4" adapter for fireplace connection (supplied with the unit)

Make a 4 1/4" (110 mm) hole in the outside wall of the house at the chosen location. From outside, place the outside air register in the hole (open side down) and fasten the register to the wall, with screws as shown (see figure 22). Slip the pipe into the insulated sleeve. Place the insulated pipe over the register tube and over the fireplaces outside air connector (see figure 23). At each end, carefully pull back the insulation and plastic cover exposing the flexible pipe. Using the aluminum tape provided, wrap the tape around the joint between the flexible pipe and the air inlets. Carefully push the insulation and plastic cover back over the pipe. Using aluminum tape, fasten the plastic cover in place.

NOTE: We recommend not exceeding 20 feet of 4" flexible pipe. If you require a longer length we recommend that you use a 5" diameter flexible pipe for the complete run up to 30 feet and a 6" diameter pipe for a run of up to 40 feet.

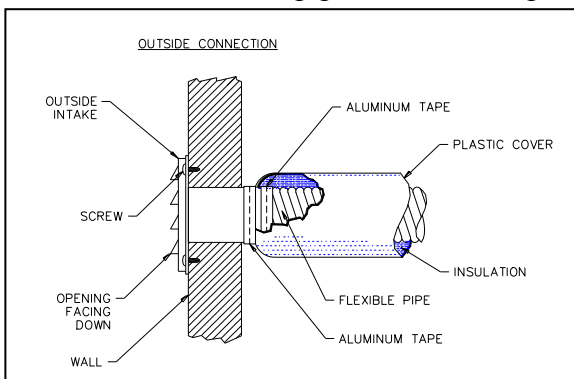

Figure 22

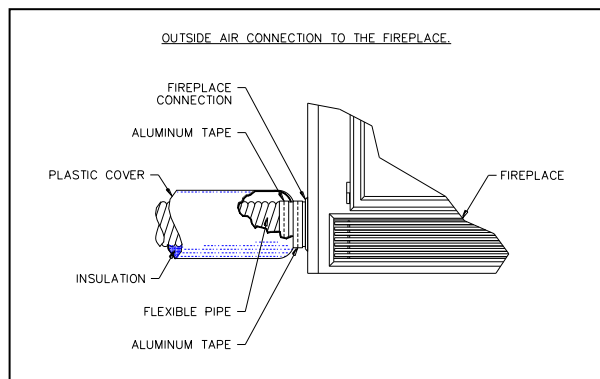

Figure 23

4. THE CHIMNEY

4.1 CHIMNEY INSTALLATION NOTES

1. If possible, install an interior chimney as it will provide better performance. In areas with continuous temperatures below -18°C (0°F), the use of an exterior chimney increases the likelihood of operating problems such as low draught, high rate of creosoting, and poor start-up characteristics. Exterior chimneys are also prone to down-drafting and flow reversal. Installations, which are located on lower floors in the house, such as in a basement, in combination with outside chimney, are especially prone to flow reversal.

NOTE: In areas where winter temperatures are normally below freezing, the air cooled chimney may produce condensation. This condensation may corrode the top of the fireplace and is not covered under warranty. For optimum performance of your fireplace, Security Chimneys International recommends the use of an ASHT+/HT6103+ or S2100+/HT6000+ chimneys.

2. The Security fireplace model BIS Ultima™ CF fireplace is listed only with Security Chimneys International Ltd 6" diameter chimney systems.
3. A chimney venting a fireplace shall not vent any other appliance.
4. The minimum chimney height is 12 ft. (3.7 m).
5. All chimney installations must include at least one support. Reducing the amount of chimney weight on the fireplace will help avoid the noise created when the fireplace expands. This can be achieved by having the chimney supported by the supports. The maximum chimney length that can be supported by the fireplace is 9 ft. (2.75 m) for S-2100+/HT6000+, 12 ft. (3.7 m) for ASHT+ / HT6103+ and 26 ft. (8 m) for AC chimney. In altitude, add 18" (450 mm) to the chimney for every 2000 feet (600 m) above sea level.
6. The chimney must extend at least 3 ft. (915 mm) above its point of contact with the roof and at least 2 ft. (610 mm) higher than any wall, roof or building within 10 ft. (3m) of it (Figure 24).

7. If the chimney extends higher than 5 ft. (1500 mm) above its point of contact with the roof, it must be secured using a roof brace.
8. A rain cap must be installed on top of the chimney. Failure to install a rain cap may cause corrosion problems.
9. Cut and frame square holes in all floors, ceilings, and roof that the chimney will go through to provide a 2" (50 mm) clearance between the chimney and any combustible materials. Do not fill this 2" space with insulation or any other combustible material.

10. Portions of the chimney which may extend through accessible spaces must be enclosed to avoid contact with combustible materials or damage the chimney.

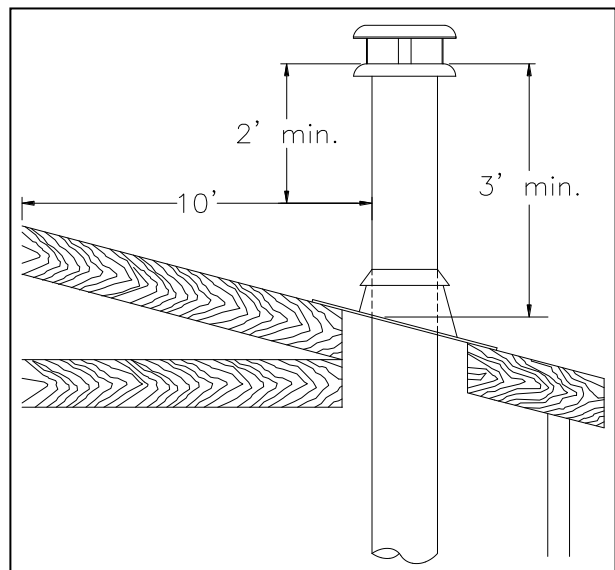

Figure 24

4.2 CHIMNEY INSTALLATION INSTRUCTIONS

1. Cut and frame the holes in the ceiling, floor and roof where the chimney will pass (see figure 25). Use a plumb bob to line up the center of the holes. The sizes are indicated in table 1 for the floor and ceiling holes and table 2 (page 24) for the roof holes.

CHIMNEY MODEL	SQUARE HOLE SIZE OPENING
ASHT+ / HT6103+	12 3/8" (314 mm)
S-2100+ / HT6000+	14 1/8" (359 mm)
AC	15 " (380 mm)

Table 1

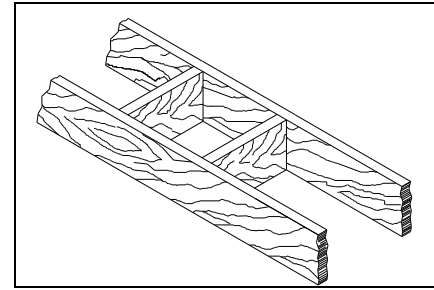

Figure 25

2. From below, install a firestop in each ceiling/floor separation through which the chimney will pass. At the attic level, install an attic radiation shield from above (figures 26 & 27).
3. For ASHT+ / HT6103+ and S-2100+ / HT6000+ chimneys, place the first chimney length on the fireplace. To lock it in place, turn ¼ of a turn clockwise. With the AC chimney, you must use a starter section before installing the first chimney length (figure 28). Continue installing chimney lengths making sure to lock each length in place.
4. Every time the chimney passes through a ceiling or a wall, install the appropriate firestop. When you reach the desired height, install the roof support. (Refer to instructions included with the support).
5. Then, put the roof flashing in place and seal the joint between the roof and the flashing with roofing pitch (see figures 29 & 30). For sloping roofs, place the flashing under the upper shingles and on top of the lower shingles. Nail the flashing to the roof, using roofing nails.
6. Place the storm collar over the flashing, and tighten it with the bolt supplied. Finally, seal the joint between the storm collar and the chimney, using silicone caulking.
7. Install the chimney cap.

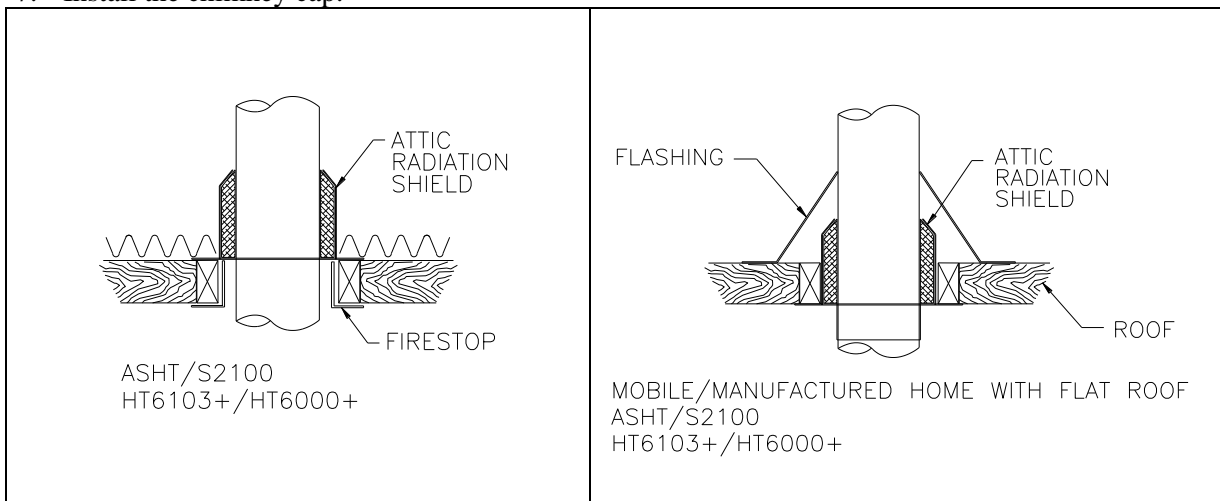

Figure 26

Figure 26a

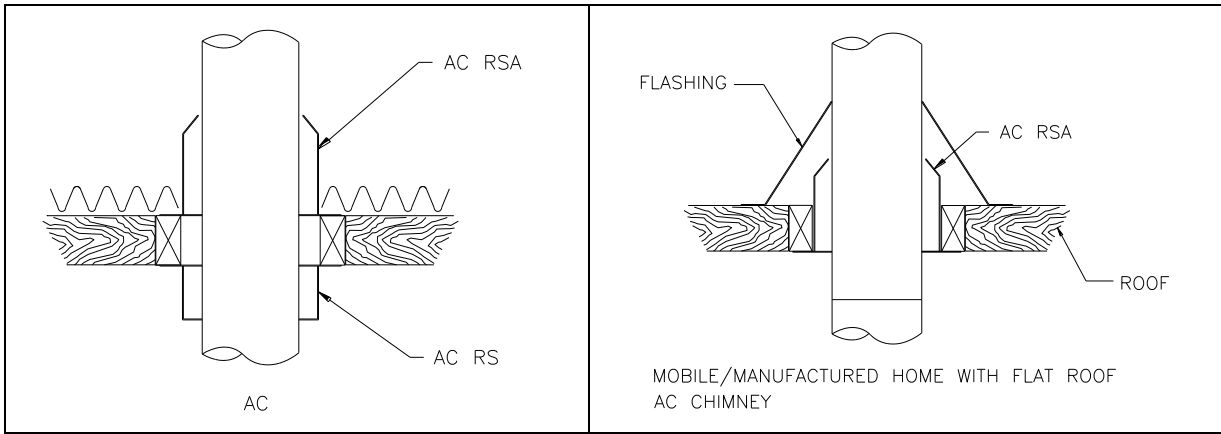

Figure 27

Figure 27a

AC CHIMNEY INSTALLATION (AIR COOLED GALVALUME CHIMNEY)

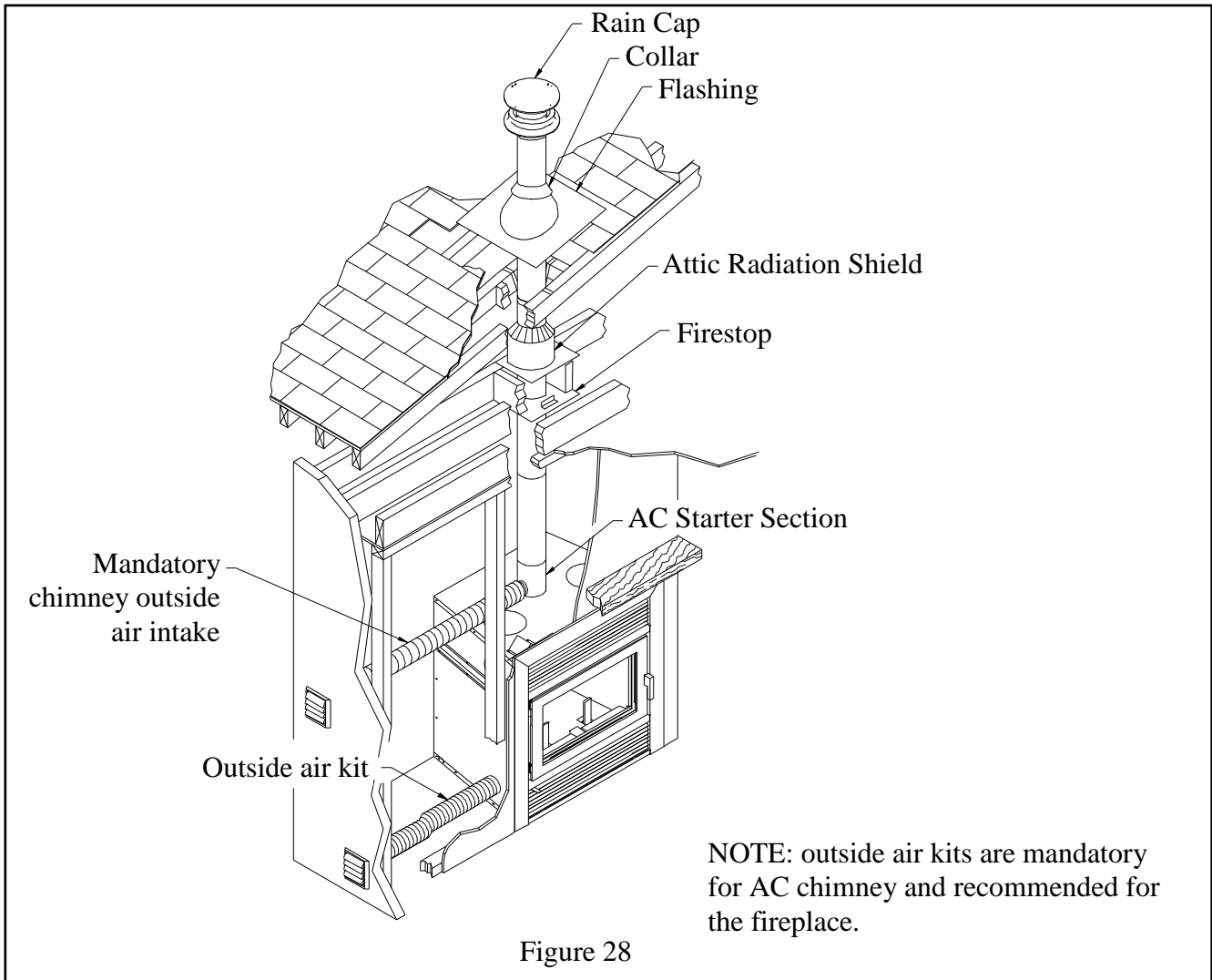

Figure 28

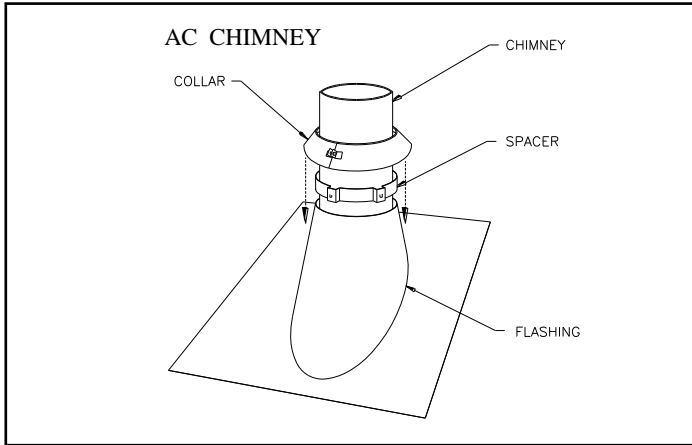

Figure 29

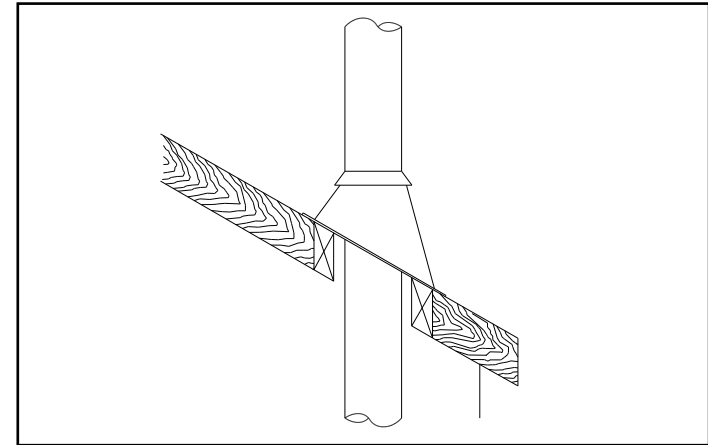

Figure 30

Table 2

ROOF DOWN SLOPE HOLE SIZE			
SLOPE	ASHT+ / HT6103+	S-2100+ / HT6000+	AC
Roof Pitch	6"	6"	6"
0 *	12 3/8" (314 mm)	14 1/8" (359 mm)	15" (380 mm)
2/12	12 9/16" (319 mm)	14 3/8" (365 mm)	15 3/8" (390 mm)
4/12	13" (330 mm)	14 7/8" (378 mm)	16 1/8" (410 mm)
6/12	13 7/8" (352 mm)	15 3/4" (400 mm)	16 7/8" (430 mm)
8/12	14 7/8" (378 mm)	17" (432 mm)	18 1/4" (465 mm)
10/12	16 1/8" (410 mm)	18 3/8" (467 mm)	19 5/8" (500 mm)
12/12	17 1/2" (445 mm)	20" (508 mm)	21 3/8" (545 mm)
* CROSS SLOPE HOLE SIZE			

4.3 OFFSET CHIMNEY INSTALLATION

The minimum chimney height when using elbows is:

Fireplace model	BIS ULTIMA™ CF
Chimney model	ASHT+ / HT6103+ / S-2100+ / HT6000+ / AC
Vertical installation	12 ft. (3.66 m)
Two (2) elbows	15 ft. (4.57 m)
Four (4) elbows	17 ft. (5.18 m)

Table 3

NOTE: A maximum of 2 offsets is allowed.

After reaching the location requiring the elbow, proceed as follows:

ASHT+ / HT6103+ / S-2100+ / HT6000+ Chimneys

1. Install the first elbow; turn it in the required direction. Fasten it to the chimney with the three (3) ½" (12 mm) metal screws provided with the elbow.
2. Install the necessary chimney lengths to achieve the required offset. Lock the chimney lengths together: it is recommended to use three (3) ½" (12 mm) screws. If the offset length is made of two (2) chimney lengths or more, use an offset or roof support halfway up the offset. If penetrating a wall, install a wall radiation shield (see figures 32 & 33).
3. Use another elbow to turn the chimney vertically. Secure the elbow, using three (3) ½" (12 mm) screws (provided with the elbow).
4. Use a plumb bob to line up the centre of the hole. Cut a hole for the chimney in the ceiling/floor. Frame this hole as described previously (refer to page 22).
5. From below, install a firestop (See figure 26).
6. A support (ST+ or SO+) must be used on the first 15' section (5 m.).
7. Continue with the regular installation.

AC Chimney

1. Install the first elbow. Turn it in the required direction. To lock it in place, turn 1/8 of a turn. Fasten the straps attached to the elbow to the surrounding frame, using nails or drywall screws (figure 31).
2. Install the necessary chimney lengths to achieve the required offset. Lock the chimney lengths together. If penetrating a wall, use a wall radiation shield.
3. Use another elbow to turn the chimney vertically. Lock it to the chimney. Fasten the straps attached to the elbow to the surrounding framing using nails or drywall screws.
4. Use a plumb bob to line up the centre of the hole. Cut a hole for the chimney in the ceiling. Frame this hole as described previously.
5. From below, install a firestop. (See figure 27).
6. Continue with the regular installation.

N.B.: An AC-SB starter section must be used before installing an elbow. When an offset is needed immediately off the top of the fireplace, a starter section allowing a 4" offset (AC-SBO) is available.

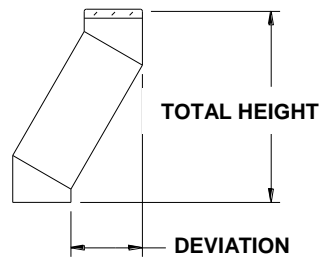

CHIMNEY 6"	ELBOW	DEVIATION & HEIGHT	ONE LENGTH BETWEEN ELBOWS					TWO LENGTHS BETWEEN ELBOWS							
			8"	12"	18"	24"	36"	48"	8" & 48"	12" & 48"	18" & 48"	24" & 48"	36" & 48"	48" & 48"	
Secure Temp ^{ASHT+} Nova Temp ^{HT6103+}	15°	DEVIATION	3 5/16" (84mm)	4 5/16" (110mm)	5 7/8" (149mm)	7 7/16" (189mm)	10 1/2" (267mm)	13 5/8" (346mm)	15 3/8" (391mm)	16 7/16" (418mm)	18" (457mm)	19 1/2" (495mm)	22 5/8" (575mm)	25 3/4" (654mm)	
		HEIGHT	15 11/16" (398mm)	19 9/16" (497mm)	25 3/8" (645mm)	31 3/16" (792mm)	42 3/4" (1086mm)	54 3/8" (1381mm)	60 15/16" (1548mm)	64 13/16" (1646mm)	70 9/16" (1792mm)	76 3/8" (1940mm)	87" (2210mm)	99 9/16" (2529mm)	
	30°	DEVIATION	7 7/16" (189mm)	9 7/16" (240mm)	12 7/16" (316mm)	15 7/16" (392mm)	21 7/16" (545mm)	27 7/16" (697mm)	30 13/16" (783mm)	32 13/16" (833mm)	35 13/16" (910mm)	38 13/16" (986mm)	44 13/16" (1138mm)	50 13/16" (1291mm)	
		HEIGHT	20" (508mm)	23 1/2" (597mm)	28 11/16" (729mm)	33 7/8" (860mm)	44 1/4" (1124mm)	54 11/16" (1389mm)	60 9/16" (1538mm)	64" (1627mm)	69 1/4" (1759mm)	74 7/16" (1891mm)	84 13/16" (2154mm)	95 1/4" (2419mm)	
	45°	DEVIATION	10 5/16" (262mm)	13 3/16" (335mm)	17 3/8" (441mm)	21 5/8" (549mm)	30 1/8" (765mm)	38 5/8" (981mm)	43 7/16" (113mm)	46 1/4" (1175mm)	50 1/2" (1283mm)	54 3/4" (1391mm)	63 1/4" (1607mm)	71 11/16" (1818mm)	
		HEIGHT	17 13/16" (452mm)	20 5/8" (524mm)	24 7/8" (632mm)	29 1/8" (740mm)	37 5/8" (956mm)	46 1/8" (1172mm)	50 15/16" (1294mm)	53 3/4" (1365mm)	58" (1473mm)	62 1/4" (1581mm)	70 3/4" (1797mm)	79 3/16" (2011mm)	
Secure Temp ^{S2100+} Nova Temp ^{HT6000+}	15°	DEVIATION	3 5/16" (84mm)	4 5/16" (110mm)	5 7/8" (149mm)	7 7/16" (189mm)	10 1/2" (267mm)	13 5/8" (346mm)	15 1/2" (394mm)	16 1/2" (419mm)	18 1/16" (459mm)	19 5/8" (498mm)	22 3/4" (578mm)	25 13/16" (656mm)	
		HEIGHT	16" (406mm)	19 7/8" (505mm)	25 11/16" (652mm)	31 1/2" (800mm)	43 1/16" (1094mm)	54 5/8" (1387mm)	61 7/16" (1561mm)	65 1/4" (1657mm)	71 1/16" (1805mm)	76 7/8" (1953mm)	88 1/2" (2248mm)	100 1/16" (2542mm)	
	30°	DEVIATION	7 3/8" (187mm)	9 3/8" (238mm)	12 3/8" (314mm)	15 3/8" (391mm)	21 3/8" (543mm)	27 3/8" (695mm)	30 7/8" (784mm)	32 7/8" (835mm)	35 7/8" (911mm)	38 7/8" (987mm)	44 7/8" (1140mm)	50 7/8" (1292mm)	
		HEIGHT	20 11/16" (525mm)	24 3/16" (614mm)	29 3/8" (746mm)	34 9/16" (878mm)	44 15/16" (1141mm)	55 5/16" (1405mm)	61 3/8" (1559mm)	64 7/8" (1648mm)	70 1/16" (1780mm)	75 1/4" (1911mm)	85 5/8" (2175mm)	96" (2438mm)	
	AC 6"	15°	DEVIATION	---	4 13/16" (122mm)	6 1/8" (156mm)	---	11" (280mm)	14 1/8" (359mm)	---	16 7/8" (429mm)	18 7/16" (468mm)	---	23" (584mm)	26 3/16" (665mm)
			HEIGHT	---	27 11/16" (703mm)	33 1/2" (851mm)	---	50 7/8" (1292mm)	65 1/2" (1588mm)	---	72 5/8" (1845mm)	78 7/16" (1992mm)	---	95 3/4" (2432mm)	107 3/8" (2727mm)
30°	DEVIATION	---	9 3/8" (238mm)	12 3/8" (314mm)	---	21 3/8" (543mm)	27 3/8" (695mm)	---	32 5/8" (829mm)	35 5/8" (905mm)	---	44 5/8" (1134mm)	50 5/8" (1286mm)		
	HEIGHT	---	25 3/4" (654mm)	31" (878mm)	---	46 1/2" (1181mm)	57" (1448mm)	---	66" (1676mm)	71 1/4" (1810mm)	---	86 7/8" (2207mm)	97 1/4" (2470mm)		
*** NOTE : With the ACBI chimney, a starting length of 6" high must be used on top of the fireplace before installing an elbow ***															

Table 4

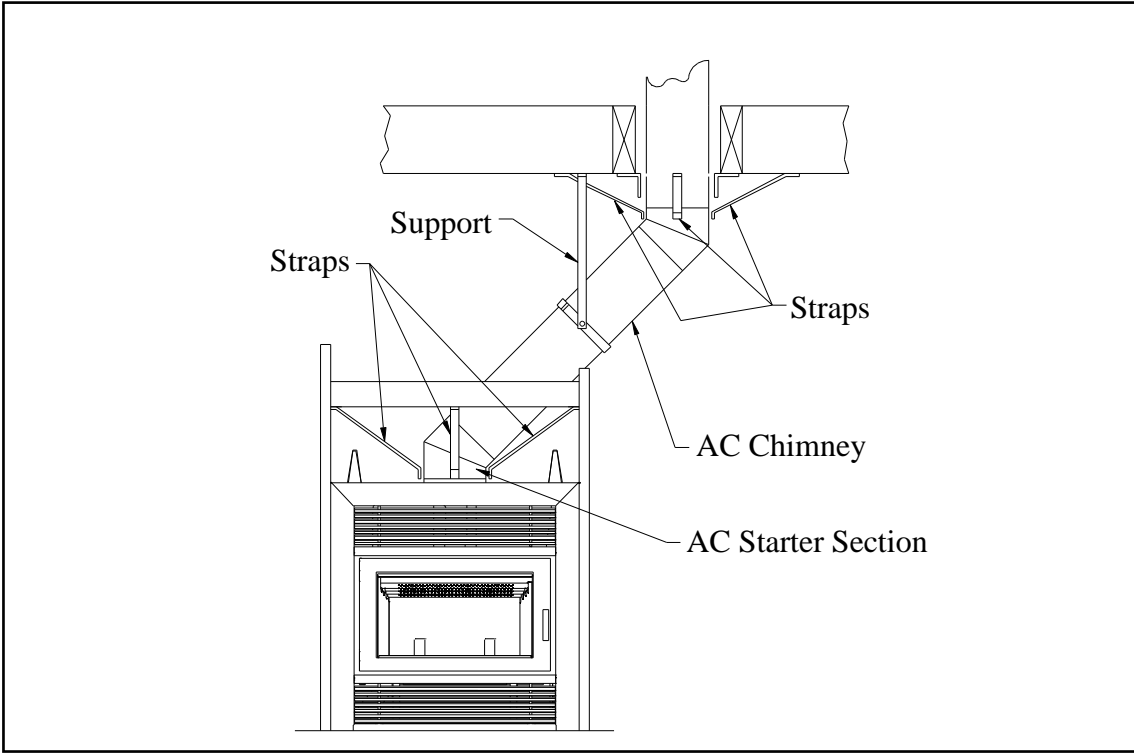

Figure 31

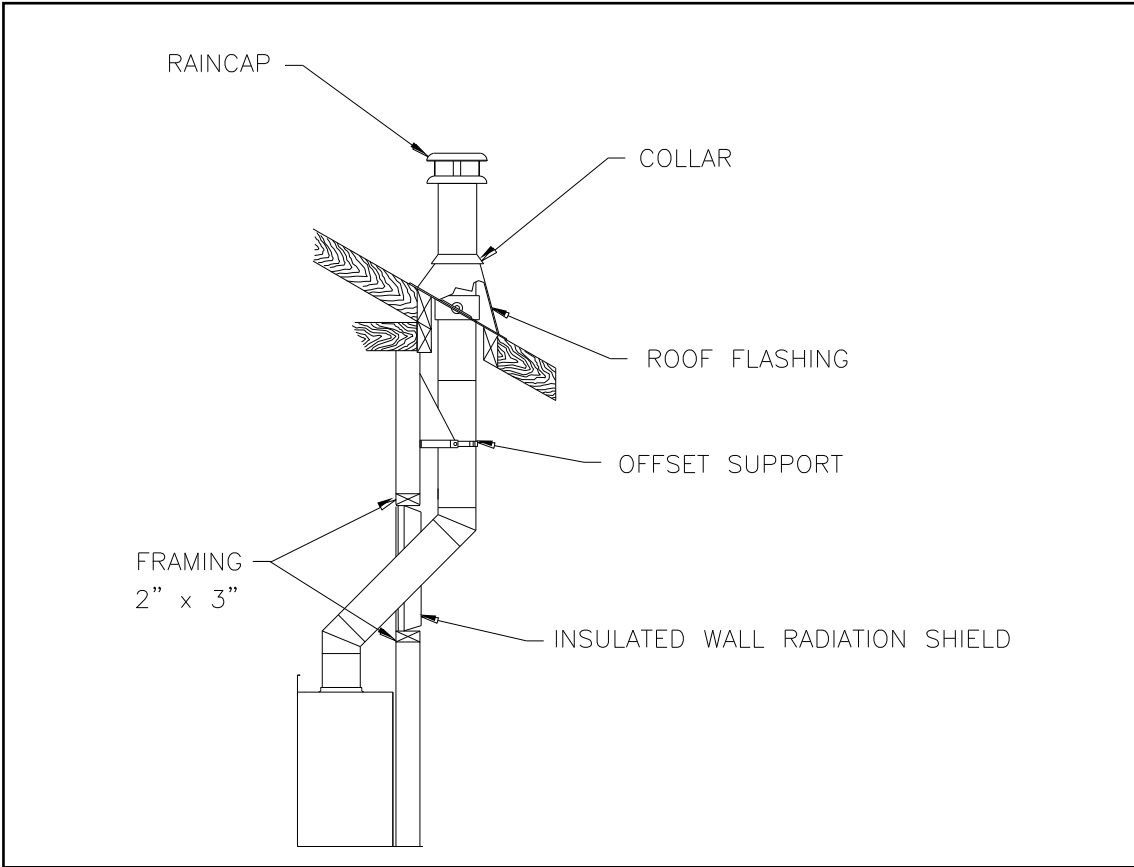

Figure 32

4.4 ANGLED WALL RADIATION SHIELD (RSM+, RSMI30, RSMI45)

When traversing a combustible wall with the chimney at a 30° or 45° angle, an angled firestop or wall radiation shield must be installed. Only one is required.

Note: 45° angle for Canada only

In cold climate locations, we recommend that you use the insulated wall radiation shield since it will maintain the home's thermal barrier.

RSM+ and RSMI30, RSMI45		
CHIMNEY MODEL	ANGLE	HOLE SIZE
ASHT+ / HT6103+ (6" dia.)	30°	283 mm x 781 mm (11 1/8" x 30 3/4")
Canada only	45°	283 mm x 518 mm (11 1/8" x 20 3/8")
S-2100+ / HT6000+ (6" dia.)	30°	327 mm x 881 mm (12 7/8" x 34 11/16")
AC (6" dia.)	30°	380 mm x 972 mm (15" x 38 1/4")

Table 5

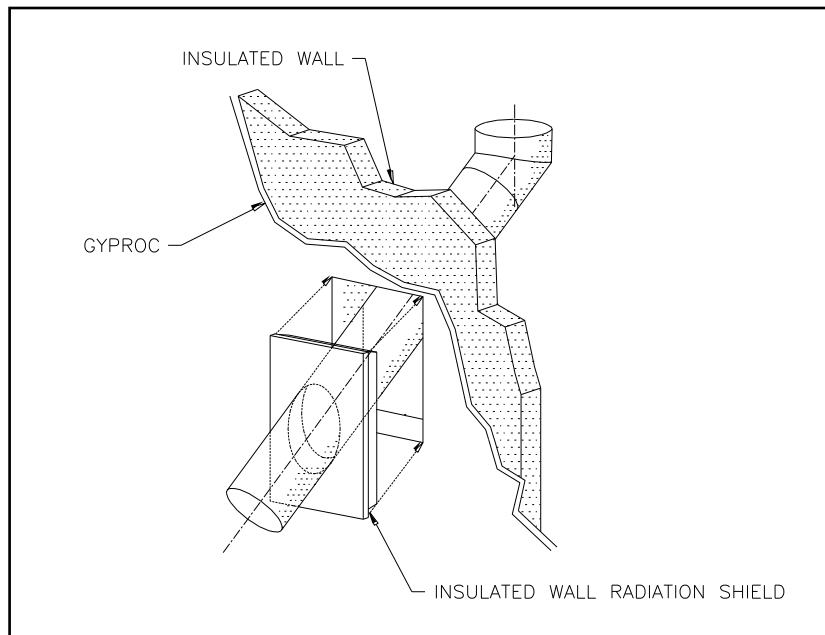

Figure 33

4.5 CHIMNEY SUPPORT INSTALLATION

Universal Roof Support

This support has three possible uses:

1. For ASHT+ / HT6103+ and S-2100+ / HT6000+, it must be used on a roof to support the chimney.
2. It may be used on a floor, ceiling or roof above an offset to support the chimney above the offset.
3. It may be used on a floor, ceiling or roof as a supplementary support

Table 6 gives maximum height of supported chimney.

NOTE: For the AC chimney, a support section must be used every 40 ft. (12 m) instead of the universal roof support (ST).

For roof support installation, refer to the instructions provided with the support.

Universal Offset Support

This support is used to support the chimney above an offset. When the chimney offset is used to traverse a wall this support may be used on the wall to support the chimney. The maximum heights are given in Table 6. For offset support installation, refer to the instructions provided with the support.

CHIMNEY MODEL	MAXIMUM HEIGHT OF SUPPORTED CHIMNEY	
	OFFSET SUPPORT	ROOF SUPPORT
ASHT+ / HT6103+ (6" dia.)	28 ft. (8.54m)	29 ft. (8.84 m)
S-2100+ / HT6000+ (6" dia.)	18 ft. (5.49 m)	20 ft. (6.1 m)
AC (6" dia.)	40 ft. (12.19 m)	50 ft. (15.20 m)

Table 6

4.6 CHIMNEY CHASE AND MULTIPLE TERMINATIONS

For the purpose of this manual, a chimney chase is considered a part of the chimney system rather than part of a building. The termination must be placed a minimum of 18" (460 mm) above the chase.

For installations where more than one chimney is located in the same chase or within the same area, we suggest that their terminations be separated by at least 16" (410 mm) horizontally, and 18" (460 mm) vertically. This separation is to prevent smoke migrating from one chimney to another (see figure 34).

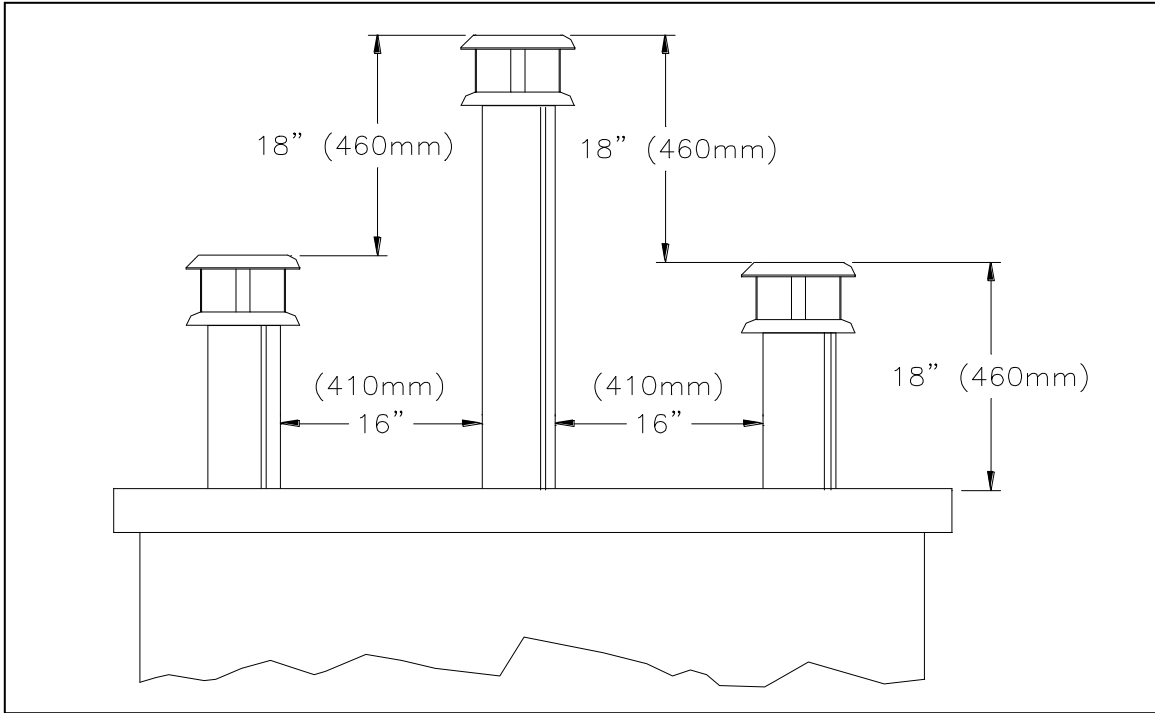

Figure 34

4.7 CHIMNEY ADAPTOR (S-2100+ / HT6000+)

The fireplace is normally supplied with a chimney adaptor suitable for the ASHT+ / HT6103+ chimney. If you want to install an S-2100+ / HT6000+ chimney, an adaptor is available (6UCA) (figure 35). A separate starter section will also be required if AC chimney is installed.

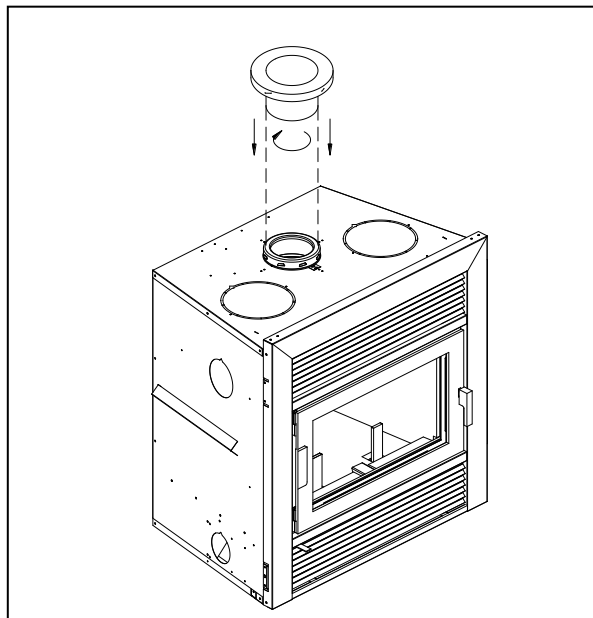

Figure 35

4.8 INSTALLATION INSTRUCTIONS FOR MASONRY APPLICATION

WARNING: Before starting the installation, the masonry chimney must be inspected by a qualified sweep.

The following requirements must be respected:

1. The chimney must be absolutely clear of any soot residue or creosote. Check for cracks, loose or missing bricks that could inhibit correct installation of the liner.
2. The clearance to combustible must be a minimum of 1" between the outside of the masonry and any wood framing or loose insulation.
3. The chimney must be built in accordance with the current building code.
4. No other appliance can be connected to the same chimney.
5. The clearances to combustible for the BISUMA or BISPMA and BISUMA30 or BISPMA30 connectors are 2" on the side and bottom and 16" at the top.
6. **The connector parts are not necessary if the connection between the insulated length and the stainless steel liner is done within the masonry chimney.**

Installation:

The chimney must be relined with a stainless steel liner model Tubinox or Projet SS of the same diameter as the outlet of the fireplace.

For connection at 45° angle, a special connector (BISUMA for the BIS Ultra™, BIS Ultima™ and BIS Ultima™ CF fireplaces or BISPMA for the BIS Panorama fireplace) must be used to connect the liner to the insulated chimney. For connection at 30°, use the BISUMA30 or BISPMA30 connectors.

See typical installation illustrated below.

Follow these steps:

- 1- Position the fireplace in its location. Temporarily install the ASHT+ elbow on the top of the fireplace and, using a level, mark with an oval the location where the flue liner will enter the masonry chimney.
- 2- In the middle of the oval, drill a hole in the masonry chimney at 45° or 30°.
- 3- Increase the size of the hole until a 45° or 30° Tubinox liner elbow can be easily slipped through.
- 4- Slide the liner down from the top of the masonry chimney until you reach the hole level.
- 5- Slip through the hole a 45° or 30° liner elbow and connect it to the liner.
- 6- Add a small liner section to the liner elbow which will allow the liner to extend at least 12" (measured at the top of the liner) from the masonry chimney.
- 7- Seal the opening around the liner with high temperature refractory cement.
- 8- The next steps must be done in the following order :

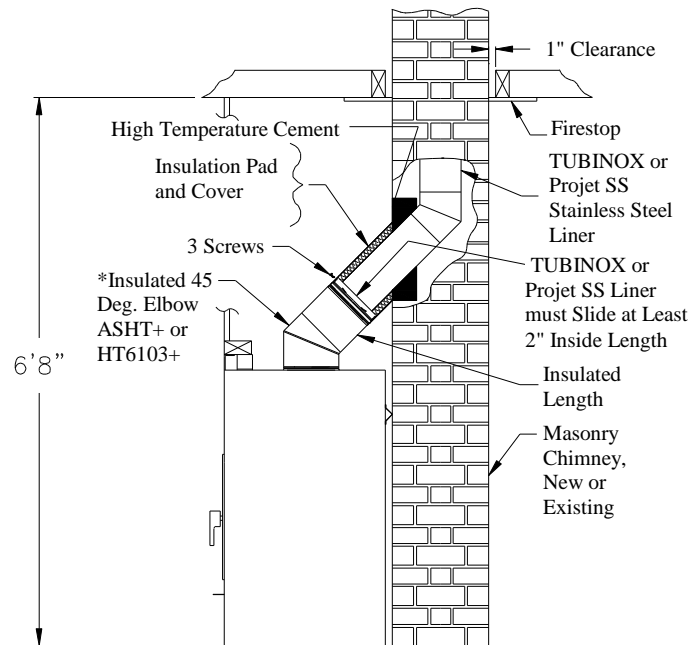

- A. Select the ASHT + length that will fit between the elbow and the liner so that it will slide at least 2" over the liner section. (You may need to cut the liner for a better fit).
- B. Take that section and the BISUMA or BISPMA (BISUMA30 or BISPMA30) cover and slide it over the liner. Make sure you have enough opening to be able to install the ASHT+ elbow without difficulty.
- C. Install the 45° or 30° elbow on the fireplace.
- D. Slide the length section back down on the elbow and twist lock the two together.
- E. Pull the cover down over the length and install the insulation pad over the liner; be careful to cover the liner completely.
- F. Slide back the cover over the insulation and fix it in place using the 3 metal screws supplied.

5. PARTS AND COMPONENTS LIST (AC Chimney)

<u>Description</u>	<u>Part No.</u>
Finishing kits	
Louver kit	LOUVRECF
Clean face kit	CAPPINGCF
Lengths	
12" length	AC6L12
18" length	AC6L18
36" length	AC6L36
48" length	AC6L48
15° elbow	AC6E15
30° elbow	AC6E30
Rain cap	AC6CPR
Spark arrester screen	PE+
Supports	
Offset support	XSO+
Support section	AC6SL
Roof support	XST+
Starter section	AC6SB
Roof brace	XBS2+
Wall band	XBM+
Firestop	
Firestop	ACBF
Radiation shield	ACRS
Attic radiation shield	ACRSA
Wall radiation shield 30°	ACRSM30
Insulated wall radiation shield 30°	ACRSMI30
Wall radiation shield 45°	ACRSM45
Insulated wall radiation shield 45°	ACRSMI45
Outside air kit (chimney) (flex, insulation, outside register and coupling)	ACZI
Flat roof flashing	ACF
Adjustable roof flashings	
1/12 - 7/12 (5° - 30°)	ACFA
8/12 - 12/12 (30° - 45°)	ACFB
12/12 - 21/12 (45° - 60°)	ACFBB
Peak roof flashings	
1/12 - 7/12 (5° - 30°)	ACFP
8/12 - 12/12 (30° - 45°)	ACFPB
Storm collar	ACFC

6. OPTIONS

Gravity kit:

<u>Complete double ducting system including:</u> 2 elbows 90°, 2 telescopic lengths, 2 grill supports and 2 black grills	<u>Part No.:</u> 7B30ZK-1
Black grill with support	7B30ZO
Brass grill for 7B30ZK	7B30ZGB
Elbow 90°, 8" dia.	7B26ZE90
Elbow 45°, 8" dia.	7B26ZE45
Telescopic length, 8" dia.	7B26ZLA
Adjustable length 8" dia. (2" - 5")	7B26ZL2A
Radiation shield	7B26ZR

Central forced air kit:

<u>Central forced air kit including:</u> blower (BISZY), flex adaptor (BISAF), 2 clamps, variable speed control (VRUW), thermo-disk (VTU), fan to flexible pipe adapter(BISAVF), back draft damper (BISBD), aluminum tape	BISFWK-1
Fireplace to Flex adaptor and 2 clamps	BISAF
Flexible pipe 5" I.D. x 15 ft. Long	5FLEX15
Flexible pipe 5" I.D. x 30 ft. Long	5FLEX25
Blower 250 CFM for central forced air kit	BISZY
Blower variable speed control with decorative wall plate for (BISZY)	VRUW
Thermo-disk, on/off blower control for (BISZY)	VTU
Fan to Flexible pipe adaptor	BISAVF
Heating and cooling thermostat	HCTW
Back draft damper	BISBD

Fireplace:

Rigid fire screen	BUCEBWZN
Heat activated on/off pre-wired fan kit (included)	UZY6
Masonry chimney adaptor	BISUMA
Outside air kit	UZI

7. APPENDIX

SPECIFICATIONS

Weight	385 lbs
Height	36"
Width	36"
Depth	24 1/2"
Chimney weight ASHT+ (6" dia.):	6.25 lb/ft.
Chimney weight S-2100+ (6" dia.):	10.8 lb/ft.

CLEARANCE TO COMBUSTIBLES

The following clearances meet the minimum requirements for a safe installation

Side wall:	24" (324 mm) measured from the fireplace side
Ceiling:	6' 8" (2032 mm) measured from the base of the fireplace
Fireplace enclosure:	Bottom: 0" Side: 0" to spacers Back: 0" to spacers
	Top: Do not fill the space above the fireplace with any material (Except the wood framing. See page 13, Figure 8)
Chimney:	2" (50 mm)
Mantel:	45" (1143 mm) measured from the base of the fireplace

REPLACEMENT PARTS

Baffle refractory (2 pieces)	PR-ISO2205
Back refractory	PR-SR2996
Right side refractory	PR-SR2997D
Left side refractory	PR-SR2997G
Bottom refractory	PR-SR3018
Front refractory, right side	PR-SR2202D
Front refractory, left side	PR-SR2202G
Secondary air tube	PR-SR2271
Secondary air tube lock	PR-SR2214
Cast-iron log supports (2)	PR-SR3026
Facing:	
Top trim	PR-SR3033
Bottom trim	PR-SR3020
Top frame	PR-SR2995
Left side frame	PR-SR2994G
Right side frame	PR-SR2994D
Fireplace top	PR-SR2500
Fireplace left side	PR-SR2502
Fireplace right side	PR-SR2503
Fireplace back	PR-SR2499
Touch up spray paint black (SBMB6309)	70K99
Wooden door handle	PR-SR3027
Door rod and lock	PR-SR2855
Ceramic glass panel	PR-SR3004
Door gasket	PR-SR1823P
Glass gasket	PR-SR1685J
Hinges (door & fireplace)	PR-SR1933
Complete door	PR-SR3003